



EX D

FLAMEPROOF SOLUTIONS TECHNICAL DATA OVERVIEW

Ex d IIB		TERMINAL BOXES, CONTROL STATIONS AND CONTROL PANELS	Page 7
	EJB range	Enclosures with flanged cover manufactured in aluminium alloy	▶ P. 9-14
	EJB/W range	Enclosures with flanged cover and windows manufactured in aluminium alloy	▶ P. 15-22
	EJB/X range and EJB/X/W range	Enclosures with flanged cover with or without window manufactured in stainless steel	▶ P. 23-28
	ASM range	Enclosures with flanged cover and windows manufactured in cast iron	▶ P. 29-31
Ex d IIB		SWITCH DISCONNECTORS AND MOTOR STARTERS	Page 33
	SD and SF range	Switch disconnectors and fused switch disconnectors manufactured in cast iron, aluminium or stainless steel	▶ P. 35-43
	DOL and DOLSD range	Direct online motor starters with or without switch disconnectors manufactured in cast iron, aluminium or stainless steel	▶ P. 47-55
	SDS range	Star-delta motor starters manufactured in cast iron, aluminium or stainless steel	▶ P. 57-59
Ex d IIC		TERMINAL BOXES AND CONTROL PANELS	Page 61
	GUB range	Enclosures with blind threaded cover manufactured in aluminium alloy	▶ P. 63-65
	GUB/W range	Enclosures with threaded cover with circular port-hole manufactured in aluminium alloy	▶ P. 67-69
	GUB/E range	Enclosures with extension and blind threaded cover manufactured in aluminium alloy	▶ P. 71-73
	GUB/WE range	Enclosures with extension and threaded cover with circular port-hole manufactured in aluminium alloy	▶ P. 75-77
	GUB/X range	Enclosures with blind threaded manufactured in stainless steel	▶ P. 79-81

Ex d IIB/IIC EJB AND GUB APPLICATIONS

Page 83



DMT 2B Electronic earthing system - Ex d IIB
EJB application as electronic earthing system

▶ P. 85



DMT 2C Electronic earthing system - Ex d IIC
GUB application as electronic earthing system

▶ P. 86



GUB/WE-TVCC Camera housing CCTV - Ex d IIC
GUB application as camera housing

▶ P. 87

Ex d IIB CONTROL UNITS MANUFACTURED IN ALUMINIUM ALLOY

Page 89



EFDC One-row pushbutton box range – Ex d IIB+H2
Multifunction local control panels manufactured in aluminium alloy

▶ P. 91

Ex d IIC CONTROL UNITS MANUFACTURED IN ALUMINIUM ALLOY

Page 93



EFD21 Local control range – Ex d IIC
Single rotary switch control units manufactured in aluminium alloy

▶ P. 95



EFD21-LP Local control range – Ex d IIC
Single or double pushbuttons and/or pilot lights control units manufactured in aluminium alloy

▶ P. 96



EFD21-F Local control range – Ex d IIC
Single mushroom pushbutton control units manufactured in aluminium alloy

▶ P. 97













EFD21-VR Local control range – Ex d IIC
Emergency mushroom pushbutton control units with breaking glass manufactured in aluminium alloy

▶ P. 98

This datasheet does not constitute any contract obligation.

Pepperl+Fuchs reserves the right to modify the products herein illustrated without prior notice. Copyright Pepperl+Fuchs srl - Italy: +39 039 6292 1

Ex d IIC	CONTROL UNITS MANUFACTURED IN CAST IRON	Page 101
	E110 Local control range – Ex d IIC 20A Single rotary switch control units manufactured in cast iron	▶ P. 103
	E112 Local control range – Ex d IIC Local fuse units manufactured in cast iron	▶ P. 104
	E114 Local control range – Ex d IIC Single and twin indicator lamps manufactured in cast iron	▶ P. 105
	E116 Local control range – Ex d IIC Single and double pushbuttons manufactured in cast iron	▶ P. 106
	E116010 Local control range – Ex d IIC Single emergency mushroom pushbuttons manufactured in cast iron	▶ P. 107
	E118 Local control range – Ex d IIC Photocell unit manufactured in cast iron	▶ P. 108

Ex d IIC	ROUND INSTRUMENT AND JUNCTION BOXES MANUFACTURED IN ALUMINIUM ALLOY	Page 111
	SMH Instrument housing range - Ex d IIC Enclosures with threaded cover with circular port-hole suitable to contain instruments manufactured in aluminium alloy	▶ P. 113
	SEB Electronic cards housing range - Ex d IIC Boxes with threaded cover suitable to contain electronic devices manufactured in aluminium alloy	▶ P. 114
	SK Instrument housing range for thermocouple/RTD - Ex d IIC Boxes with threaded cover suitable to contain thermocouples and RTD manufactured in aluminium alloy	▶ P. 115
	SO Instrument housing range with port-hole - Ex d IIC Boxes with threaded cover with circular port-hole suitable to contain signalling/visualization equipment manufactured in aluminium alloy	▶ P. 116
	SO-E Instrument housing range with extension and port-hole - Ex d IIC Boxes with threaded cover with extension and circular port-hole suitable to contain signalling/visualization equipment manufactured in aluminium alloy	▶ P. 117

Ex d IIC	CONTROL EQUIPMENT MANUFACTURED IN ALUMINIUM ALLOY	Page 119
	FFCM Limit switch range - Ex d IIC Compact limit switch with selection of actuators manufactured in aluminium alloy	▶ P. 121

EJB RANGE

Ex d IIB



Enclosures with flanged cover manufactured in aluminium alloy

▶ P. 9-14

EJB/W RANGE

Ex d IIB



Enclosures with flanged cover and windows manufactured in aluminium alloy

▶ P. 15-22

EJB/X RANGE

Ex d IIB



EJB/X and EJB/X/W range

Enclosures with flanged cover with or without window manufactured in stainless steel

▶ P. 23-28

ASM RANGE

Ex d IIB



ASM range

Enclosures with flanged cover and windows manufactured in cast iron

▶ P. 29-31

This datasheet does not constitute any contract obligation.

Pepperl+Fuchs reserves the right to modify the products herein illustrated without prior notice. Copyright Pepperl+Fuchs srl - Italy: +39 039 6292 1

Pepperl+Fuchs Group
www.pepperl-fuchs.comUSA: +1 330 486 0002
pa-info@us.pepperl-fuchs.comGermany: +49 621 776 2222
pa-info@de.pepperl-fuchs.comSingapore: +65 6779 9091
pa-info@sg.pepperl-fuchs.com

PEPPERL+FUCHS
PROTECTING YOUR PROCESS



Description:

The EJB enclosures are made of aluminium alloy. They are rectangular shaped and complete with a flat joint cover, which is fixed by hexagonal head screws.

Application:

The enclosures are suitable to contain terminals, contactors, switches, transformers, capacitors, PLC and other electric, electronic equipment and intrinsic safety devices.

Materials:

Body and cover: copper free aluminium alloy.
Screws: stainless steel.
Brackets: galvanized steel.

Certification characteristics:

Type of Protection: II 2GD Ex d IIB Gb / Ex tb IIIC Db
II 2GD Ex d [j. G.] IIB T6 Gb / Ex tb [i.D] IIIC T85°C Db.
Class of Temperature: T6 / T85 °C → T3 / T200 °C.
Protection Degree: IP66 / IP67*.
Certificate: INERIS 10ATEX0035X.
Ambient Temp.: -20 °C / +60 °C (+40 / +50 / +55 °C).
Zones: 1 – 21 – 2 – 22.

Threads:

NPT (ANSI B1.20.1).
Metric x 1.5 (ISO 261).

Inhibiting treatments:

Standard epoxy painting RAL 7005.

On request:

*IP67 protection with o-ring.
Galvanized steel or stainless steel hinges.
Galvanized steel equipment plate.
Pushbuttons, pilot light, selector switches.
Breathing / draining valve.
Wiring.
Other epoxy painting colours different from the standards.
Special inhibiting treatment.
Other type of threads [ISO7/1 (UNI6125), PG (DIN 40430)].
Cable glands for armoured or non armoured cable.

Drawing EJB

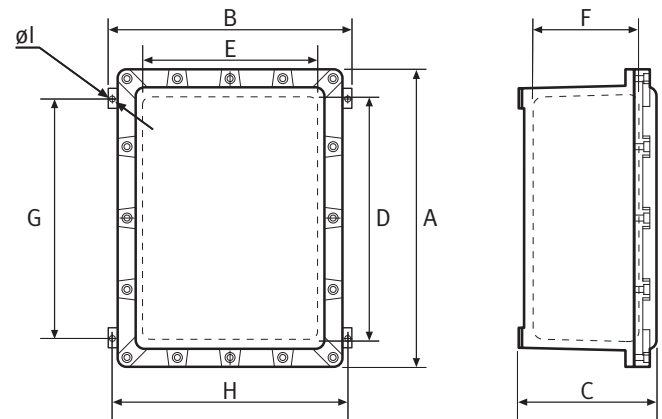

Legend:

- A - Maximum external dimension.
- B - Maximum external dimension with mounting brackets.
- C - Maximum external dimension with cover.
- D - Internal dimension.
- E - Internal dimension.
- F - Internal depth.
- G - Fixing holes wheel base.
- H - Fixing holes wheel base.
- Ø l - Fixing holes diameter.

Grounding:

External: M6 grounding point (EJB complete serie).
Internal: M5 grounding point (EJBØ → EJB14A; EJB16).
M6 grounding point (EJB15 → EJB20A; except EJB16).

EJB - Data Table

Dimensions [mm] and approx. Weight [Kg]

Type	Dimensions						Fixing			Weight
	External			Internal			G	H	Ø I	
	A	B	C	D	E	F				
EJB 0	196	128	144	140	75	105	133	108	8	3,5
EJB 1	218	178	141	155	115	110	148	158	8	5,5
EJB 2	223	226	98	160	160	65	157	206	8	4,7
EJB 2A	223	226	150	160	160	130	157	206	8	6,4
EJB 3	249	165	118	200	100	85	185	145	8	4,7
EJB 3A	249	165	146	200	100	110	185	145	8	4,8
EJB 4	260	226	139	200	160	105	188	206	8	7,8
EJB 4A	260	226	176	200	160	145	188	206	8	8,1
EJB 6	311	216	131	250	150	95	230	196	8	7,5
EJB 6A	311	216	170	250	150	130	230	196	8	9
EJB 8	375	270	173	300	200	135	282	250	10	15,6
EJB 8A*	375	270	200	300	200	155	282	250	10	16
EJB 8B	375	270	234	300	200	195	282	250	10	18,4
EJB 9	387	226	149	330	160	110	312	206	8	11,3
EJB 9A	387	226	179	330	160	145	316	206	8	12,7
EJB 9B	387	226	255	330	160	215	312	206	8	15,3
EJB 10	452	350	164	370	260	120	345	320	9	19,8
EJB 10A	452	350	207	370	260	165	345	320	9	20,6
EJB 10B	452	350	261	370	260	220	345	320	9	25,5
EJB 11*	489	415	182	400	320	135	363	385	10	29,7
EJB 11A	489	415	222	400	320	175	363	385	10	30,6
EJB 11B	489	415	269	400	320	220	363	385	10	37,3
EJB 12	505	275	184	430	195	135	404	245	9	18,6
EJB 13	510	318	210	430	230	170	398	290	10	21,9
EJB 13A	510	318	259	430	230	220	398	290	10	24,6
EJB 14	580	336	170	500	250	125	473	306	10	23,5
EJB 14A	580	336	219	500	250	180	473	306	10	28,1
EJB 15	581	460	226	500	350	170	462	430	11	40,4
EJB 15A	581	460	280	500	350	215	462	430	11	51,5
EJB 16	575	178	122	520	120	90	496	158	8	11,4
EJB 17	662	494	257	570	400	200	550	464	11	52,5
EJB 17A	662	494	377	570	400	315	550	464	11	70
EJB 17Q*	630	613	351	500	500	280	453	583	11	85
EJB 18	735	535	228	640	430	160	590	505	11	61,4
EJB 18A	735	535	281	640	430	215	590	505	11	74,4
EJB 18B	735	535	388	640	430	315	590	505	11	91,7
EJB 19	730	384	199	650	300	140	610	354	11	43,6
EJB 19A	730	384	259	650	300	205	610	354	11	46
EJB 20	915	670	330	800	550	240	697	630	14	132
EJB 20A	915	670	463	800	550	380	697	630	14	157

* Enclosures available IP67 protection degree with o-ring.
 Note: dimensions can slightly differ due to casting model tolerances.

EJB - Drilling Table

Type	Cover				Body (long side – short side)							
	M12	1/4"	1/2"	1"	1/2"	3/4"	1"	1.1/4"	1.1/2"	2"	2.1/2"	3"
EJB 0	4	4	3	3	5-4	4-3	3-1	2-1	2-1	1-1	-	-
EJB 1	6	6	6	6	6-5	5-4	4-2	2-2	2-1	1-1	-	-
EJB 2	9	9	9	5	4-4	3-3	2-2	-	-	-	-	-
EJB 2A	9	9	9	5	8-8	8-8	5-5	3-3	2-2	2-2	1-1	-
EJB 3	8	8	8	6	7-4	4-2	4-2	3-1	3-1	-	-	-
EJB 3A	8	8	8	6	8-5	8-4	5-3	3-2	3-1	2-1	-	-
EJB 4	20	20	16	9	6-5	5-4	3-3	3-2	2-2	2-1	-	-
EJB 4A	20	20	16	9	8-6	6-5	5-4	5-4	4-3	2-2	-	-
EJB 6	15	15	15	8	9-5	9-5	5-3	4-2	3-2	3-1	-	-
EJB 6A	15	15	15	8	14-8	14-8	8-5	5-3	5-2	3-2	2-1	2-1
EJB 8	20	20	20	12	12-10	12-8	10-6	7-5	5-4	3-2	2-1	2-1
EJB 8A	20	20	20	12	15-11	14-11	10-6	8-5	7-5	3-2	3-2	2-1
EJB 8B	20	20	20	12	17-12	15-12	14-9	11-8	8-6	5-3	3-2	2-1
EJB 9	18	18	18	10	9-5	9-5	6-4	5-4	4-3	3-2	-	-
EJB 9A	18	18	18	10	12-8	12-6	9-6	7-4	5-4	3-2	3-1	2-1
EJB 9B	18	18	18	10	22-12	18-10	12-9	11-5	8-5	6-2	4-2	3-1
EJB 10	20	20	20	16	12-10	12-8	9-7	6-5	5-4	4-3	3-2	-
EJB 10A	20	20	20	16	14-10	14-10	10-8	8-6	7-5	4-3	3-2	2-2
EJB 10B	20	20	20	16	18-12	18-12	15-11	11-8	8-6	5-4	4-3	3-2
EJB 11	28	28	28	24	16-12	16-12	13-9	6-5	5-4	4-3	3-3	-
EJB 11A	28	28	28	24	20-14	20-14	13-10	9-7	7-5	5-4	3-3	3-2
EJB 11B	28	28	28	24	21-18	21-18	17-14	10-8	10-8	7-5	4-3	3-2
EJB 12	20	20	20	16	20-11	20-11	12-8	11-5	7-4	4-2	4-2	3-1
EJB 13	21	21	21	18	23-11	23-11	14-8	11-6	9-5	5-3	4-2	3-2
EJB 13A	21	21	21	18	24-15	24-12	17-9	11-8	11-8	6-4	5-2	3-2
EJB 14	32	32	32	20	18-10	18-10	15-8	8-5	7-4	5-3	4-2	-
EJB 14A	32	32	32	20	27-15	26-14	20-11	12-6	11-5	6-3	4-2	3-2
EJB 15	40	40	40	30	23-17	23-17	14-10	10-8	10-7	5-4	4-3	3-2
EJB 15A	40	40	40	30	24-18	24-18	17-11	12-8	12-8	7-5	5-3	3-3
EJB 16	18	18	18	14	17-5	17-5	9-3	6-2	6-2	4-1	-	-
EJB 17	35	35	35	24	27-21	27-21	20-12	13-10	13-10	7-5	5-4	4-3
EJB 17A	35	35	35	24	32-24	32-24	21-18	18-12	17-11	14-8	8-6	5-5
EJB 17Q	42	42	42	28	30-30	22-22	18-18	17-17	14-14	8-8	7-7	5-5
EJB 18	45	45	45	32	20-14	20-12	16-12	15-10	13-8	7-5	5-3	3-3
EJB 18A	45	45	45	32	30-21	30-21	23-17	20-14	17-9	10-7	6-5	5-3
EJB 18B	45	45	45	32	36-24	36-24	30-18	26-15	18-15	14-11	8-6	8-5
EJB 19	35	35	35	28	20-10	20-10	16-8	13-7	11-5	6-3	5-2	4-2
EJB 19A	35	35	35	28	27-15	27-15	23-11	20-8	14-6	9-5	7-3	5-2
EJB 20	35	35	35	35	20-12	20-12	16-12	16-10	12-10	6-5	4-3	4-2
EJB 20A	35	35	35	35	24-18	24-18	20-15	20-12	12-10	8-6	8-4	8-4

Note: - available cable entry with 1/4" and 3/8" diameter (or other equivalent thread type) with the same maximum number of 1/2" holes.
 - the cable entries with Metric (x 1.5) threads are equivalent in number with the inches threads listed in the above table.
 The comparison between Metric (x 1.5) and inches is according to the below table.

EJB - Threads Comparison Table

Inches	1/4"	3/8"	1/2"	3/4"	1"	1 1/4"	1 1/2"	2"	2 1/2"	3"
Metric (x 1.5)	M12	M16	M20	M25	M32	M40/M42	M50	M63	M75	M85

Release date 2011-01-24 – Updated 2013-04-19 - A5

EJB - Bottom Drilling Table

Type	Bottom				
	1/2"	3/4"	1"	1.1/4"	1.1/2"
EJB 0	2	2	1	-	-
EJB 1	2	2	1	-	-
EJB 2	2	2	2	-	-
EJB 2A	2	2	2	-	-
EJB 3	2	2	1	-	-
EJB 3A	2	2	1	-	-
EJB 4	2	2	2	-	-
EJB 4A	2	2	2	-	-
EJB 6	3	3	2	-	-
EJB 6A	3	3	2	-	-
EJB 8	4	4	3	-	-
EJB 8A	4	4	3	-	-
EJB 8B	4	4	3	-	-
EJB 9	4	4	3	-	-
EJB 9A	4	4	3	-	-
EJB 9B	4	4	3	-	-
EJB 10	4	4	3	1	1
EJB 10A	4	4	3	1	1
EJB 10B	4	4	3	1	1
EJB 11	5	5	4	2	2
EJB 11A	5	5	4	2	2
EJB 11B	5	5	4	2	2
EJB 12	4	4	3	1	1
EJB 13	4	4	3	1	1
EJB 13A	4	4	3	1	1
EJB 14	5	5	3	1	1
EJB 14A	5	5	3	1	1
EJB 15	6	6	4	3	2
EJB 15A	6	6	4	3	2
EJB 16	4	4	3	1	1
EJB 17	6	6	5	3	3
EJB 17A	6	6	5	3	3
EJB 17Q	6	6	5	3	3
EJB 18	6	6	5	3	3
EJB 18A	6	6	5	3	3
EJB 18B	6	6	5	3	3
EJB 19	6	6	5	3	3
EJB 19A	6	6	5	3	3
EJB 20	6	6	5	3	3
EJB 20A	6	6	5	3	3

Note: - the cable entries with Metric (x 1.5) threads are equivalent in number with the inches threads listed in the above table.
 - the comparison between Metric (x 1.5) and inches is according to the below table.

EJB - Threads Comparison Table

Inches	1/4"	3/8"	1/2"	3/4"	1"	1 1/4"	1 1/2"	2"	2 1/2"	3"
Metric (x 1.5)	M12	M16	M20	M25	M32	M40/M42	M50	M63	M75	M85

Release date 2011-01-24 - Updated 2013-04-19 - A5

This datasheet does not constitute any contract obligation.

Pepperl+Fuchs reserves the right to modify the products herein illustrated without prior notice. Copyright Pepperl+Fuchs srl - Italy: +39 039 6292 1

EJB - Mounting Plates

Dimensions [mm]

Enclosure	A	B	C	D	E	F	Ø G	type 1	type 2
EJB 0					Not available				
EJB 1	10	20	40	130	145	100	6	X	
EJB 2	10	25	120	130	150	145	7	X	
EJB 2A	10	25	120	130	150	145	7	X	
EJB 3	10	20	37	163	183	85	6		X
EJB 3A	10	20	37	163	183	85	6		X
EJB 4	10	20	68	170	190	145	7	X	
EJB 4A	10	20	68	170	190	145	7	X	
EJB 6	10	20	75	220	235	135	7	X	
EJB 6A	10	20	75	220	235	135	7	X	
EJB 8	10	25	85	275	290	190	7	X	
EJB 8A	10	25	85	275	290	190	7	X	
EJB 8B	10	25	85	275	290	190	7	X	
EJB 9	10	25	70	297	310	145	7	X	
EJB 9A	10	25	70	297	310	145	7	X	
EJB 9B	10	25	70	297	310	145	7	X	
EJB 10	10	25	160	335	355	245	7	X	
EJB 10A	10	25	160	335	355	245	7	X	
EJB 10B	10	25	160	335	355	245	7	X	
EJB 11	15	25	110	365	380	305	7	X	
EJB 11A	15	25	110	365	380	305	7	X	
EJB 11B	15	25	110	365	380	295	7	X	
EJB 12	10	25	165	247	410	180	7	X	
EJB 13	15	25	140	394	410	210	7	X	
EJB 13A	15	25	140	394	410	210	7	X	
EJB 14	15	25	150	460	475	225	7	X	
EJB 14A	15	25	150	460	475	225	7	X	
EJB 15	15	25	280	430	465	315	8		X
EJB 15A	15	25	280	430	465	315	8		X
EJB 16	10	20	55	460	480	100	7	X	
EJB 17	15	25	295	520	540	370	8	X	
EJB 17A	15	25	295	520	540	370	8	X	
EJB 17 Q	15	30	253	459	475	475	8	X	
EJB 18	15	30	203	585	600	390	8	X	
EJB 18A	15	30	203	585	600	390	8	X	
EJB 18B	15	30	235	585	605	400	8	X	
EJB 19	15	30	103	605	620	265	8	X	
EJB 19A	15	30	103	605	620	265	8	X	
EJB 20	25	30	375	730	750	500	8	X	
EJB 20A	25	30	375	730	750	500	8	X	

Release date 2011-01-24 – Updated 2013-04-19 - A5

This datasheet does not constitute any contract obligation.

Pepperl+Fuchs reserves the right to modify the products herein illustrated without prior notice. Copyright Pepperl+Fuchs srl - Italy: +39 039 6292 1

Pepperl+Fuchs Group
www.pepperl-fuchs.com

USA: +1 330 486 0002
pa-info@us.pepperl-fuchs.com

Germany: +49 621 776 2222
pa-info@de.pepperl-fuchs.com

Singapore: +65 6779 9091
pa-info@sg.pepperl-fuchs.com

PEPPERL+FUCHS
PROTECTING YOUR PROCESS

EJB - Mounting Plates in galvanized steel, thickness 20/10 mm

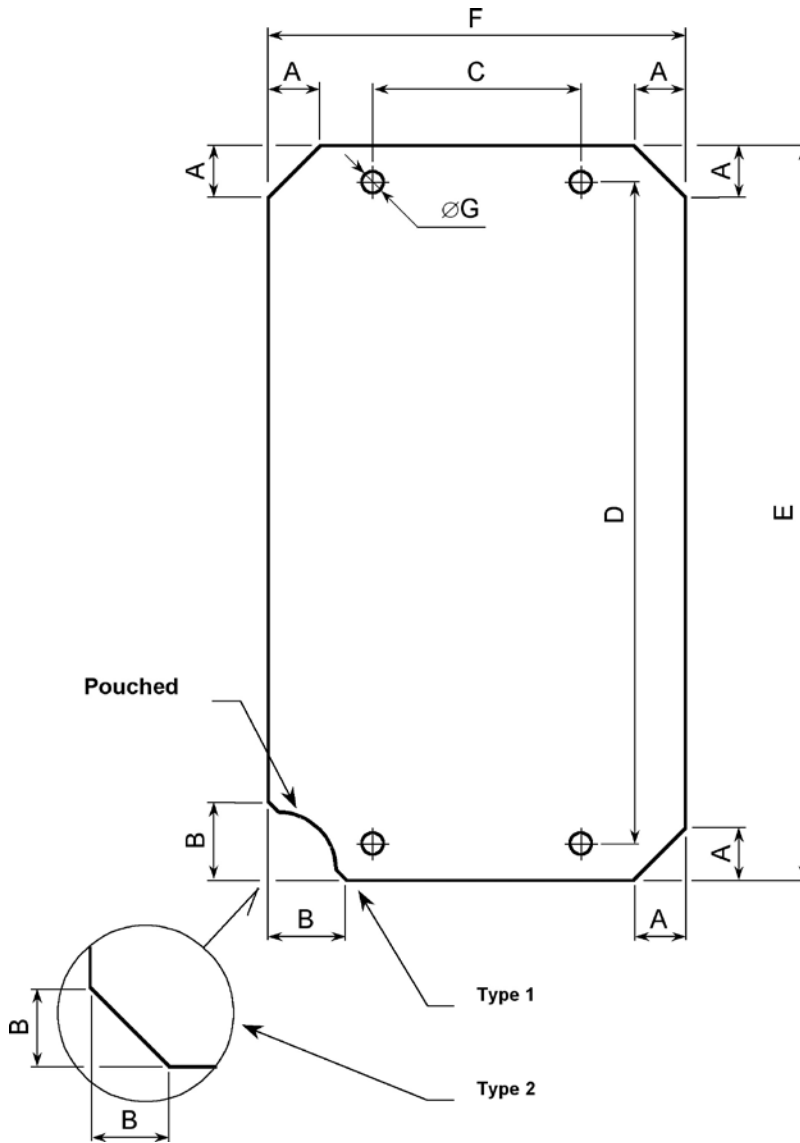

Note: the positioning of the mounting plate reported here above is purely as an example, the location of the earth screw depends on the type of enclosure.

Release date 2011-01-24 – Updated 2013-04-19 - A5

Description:

The EJB/W enclosures are made of aluminium alloy. They are rectangular shaped with a flat joint cover fixed by hexagonal head screws. In addition a window or circular port-hole for visualization can be mounted.

Application:

The enclosures are suitable to contain and visualize terminals, contactors, switches, transformers, capacitors, PLC and other electric, electronic equipment and intrinsic safety devices.

Materials:

Body and cover: copper free aluminium alloy.
 Window: thermo-resistant tempered glass.
 Screws: stainless steel.
 Brackets: galvanized steel.

Certification characteristics:

Type of Protection: II 2GD Ex d IIB Gb / Ex tb IIIC Db
 II 2GD Ex d [i. G.] IIB T6 Gb / Ex tb [i.D] IIIC T85°C Db.
 Class of Temperature: T6 / T85 °C → T3 / T200 °C.
 Protection Degree: IP66 / IP67*.
 Certificate: INERIS 10ATEX0035X.
 Ambient Temp.: -20 °C / +60 °C (+40 / +50 / +55 °C).
 Zones: 1 – 21 – 2 – 22.

Threads:

NPT (ANSI B1.20.1).
 Metric x 1.5 (ISO 261).

Inhibiting treatments:

Standard epoxy painting RAL 7005.

On request:

*IP67 protection with o-ring.
 Galvanized steel or stainless steel hinges.
 Galvanized steel equipment plate.
 Pushbuttons, pilot lights, selector switches.
 Breathing / draining valve.
 Wiring.
 Other epoxy painting colours different from the standards.
 Special inhibiting treatment.
 Other type of threads [ISO7/1 (UNI6125), PG (DIN 40430)].
 Cable glands for armoured or non armoured cable.

Drawing EJB/W

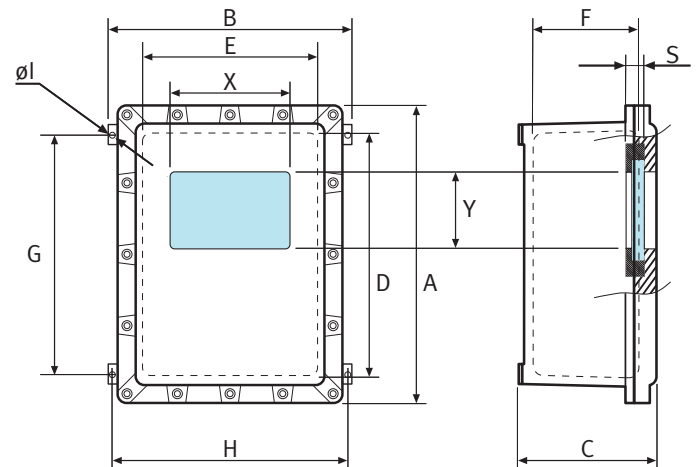

Drawing EJB/WG

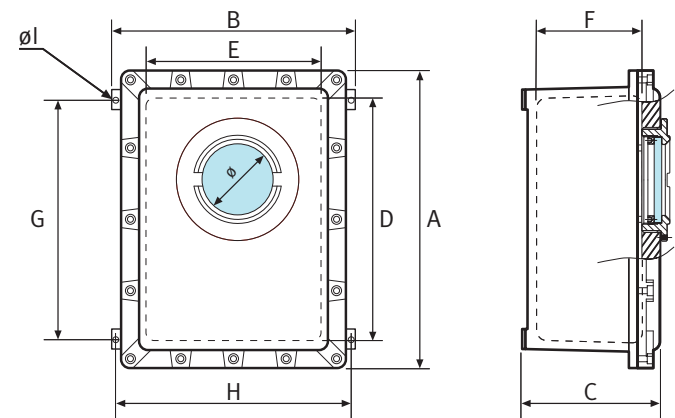

Legend:

- A - Maximum external dimension.
- B - Maximum external dimension with mounting brackets.
- C - Maximum external dimension with cover.
- D - Internal dimension.
- E - Internal dimension.
- F - Internal depth.
- G - Fixing holes wheel base.
- H - Fixing holes wheel base.
- Ø l - Fixing holes diameter.
- X - Window dimension.
- Y - Window dimension.
- S - Chassis internal thickness.
- Ø - Port-hole diameter.

EJB/W - Data Table

Dimensions [mm] and approx. Weight [Kg]

Type	Dimensions						Fixing			Weight
	External			Internal			G	H	Ø I	
	A	B	C	D	E	F				
EJB 0	196	128	144	140	75	105	133	108	8	3,5
EJB 1	218	178	141	155	115	110	148	158	8	5,5
EJB 2	223	226	98	160	160	65	157	206	8	4,7
EJB 2A	223	226	150	160	160	130	157	206	8	6,4
EJB 3	249	165	118	200	100	85	185	145	8	4,7
EJB 3A	249	165	146	200	100	110	185	145	8	4,8
EJB 4	260	226	139	200	160	105	188	206	8	7,8
EJB 4A	260	226	176	200	160	145	188	206	8	8,1
EJB 6	311	216	131	250	150	95	230	196	8	7,5
EJB 6A	311	216	170	250	150	130	230	196	8	9
EJB 8	375	270	173	300	200	135	282	250	10	15,6
EJB 8A*	375	270	200	300	200	155	282	250	10	16
EJB 8B	375	270	234	300	200	195	282	250	10	18,4
EJB 9	387	226	149	330	160	110	312	206	8	11,3
EJB 9A	387	226	179	330	160	145	316	206	8	12,7
EJB 9B	387	226	255	330	160	215	312	206	8	15,3
EJB 10	452	350	164	370	260	120	345	320	9	19,8
EJB 10A	452	350	207	370	260	165	345	320	9	20,6
EJB 10B	452	350	261	370	260	220	345	320	9	25,5
EJB 11*	489	415	182	400	320	135	363	385	10	29,7
EJB 11A	489	415	222	400	320	175	363	385	10	30,6
EJB 11B	489	415	269	400	320	220	363	385	10	37,3
EJB 12	505	275	184	430	195	135	404	245	9	18,6
EJB 13	510	318	210	430	230	170	398	290	10	21,9
EJB 13A	510	318	259	430	230	220	398	290	10	24,6
EJB 14	580	336	170	500	250	125	473	306	10	23,5
EJB 14A	580	336	219	500	250	180	473	306	10	28,1
EJB 15	581	460	226	500	350	170	462	430	11	40,4
EJB 15A	581	460	280	500	350	215	462	430	11	51,5
EJB 16	575	178	122	520	120	90	496	158	8	11,4
EJB 17	662	494	257	570	400	200	550	464	11	52,5
EJB 17A	662	494	377	570	400	315	550	464	11	70
EJB 17Q*	630	613	351	500	500	280	453	583	11	85
EJB 18	735	535	228	640	430	160	590	505	11	61,4
EJB 18A	735	535	281	640	430	215	590	505	11	74,4
EJB 18B	735	535	388	640	430	315	590	505	11	91,7
EJB 19	730	384	199	650	300	140	610	354	11	43,6
EJB 19A	730	384	259	650	300	205	610	354	11	46
EJB 20	915	670	330	800	550	240	697	630	14	132
EJB 20A	915	670	463	800	550	380	697	630	14	157

* Enclosures available IP67 protection degree with o-ring
 Note: dimensions can slightly differ due to casting model tolerances.

Release date 2011-01-24 – Updated 2013-04-19 - A5

EJB/W Window Size										
Dimensions [mm]										
Glass size	Rectangular windows									
	W0	W1	W2	W2A	W3	W3A	W4	W5	W6	W7
X	75	105	150	180	210	200	300	300	300	120
Y	75	75	105	40	150	200	50	210	80	108
S	22	22	27	22	31	36	31	36	22	35

** In order to obtain the needed depth of the enclosures, the size "S" must be deducted from the size "F".

Drawing EJB/W

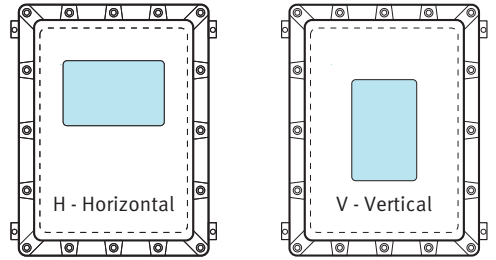

EJB/W Rectangular Glass Ubication Table

Type	W0 75x75 mm	W1 105x75 mm	W2 150x105 mm	W2A 180x40 mm	W3 210x150 mm	W3A 200x200 mm	W4 300x50 mm	W5 300x210 mm	W6 300x80 mm	W7 120x108 mm
EJB 0	-	-	-	-	-	-	-	-	-	-
EJB 1	-	-	-	-	-	-	-	-	-	-
EJB 2	H-V	-	-	-	-	-	-	-	-	-
EJB 2A	H-V	-	-	-	-	-	-	-	-	-
EJB 3	-	-	-	-	-	-	-	-	-	-
EJB 3A	-	-	-	-	-	-	-	-	-	-
EJB 4	H-V	V	-	-	-	-	-	-	-	-
EJB 4A	H-V	V	-	-	-	-	-	-	-	-
EJB 6	H-V	V	-	-	-	-	-	-	-	-
EJB 6A	H-V	V	-	-	-	-	-	-	-	-
EJB 8	H-V	H-V	V	-	-	-	-	-	-	H-V
EJB 8A	H-V	H-V	V	-	-	-	-	-	-	H-V
EJB 8B	H-V	H-V	V	-	-	-	-	-	-	H-V
EJB 9	H-V	V	-	-	-	-	-	-	-	-
EJB 9A	H-V	V	-	-	-	-	-	-	-	-
EJB 9B	H-V	V	-	-	-	-	-	-	-	-
EJB 10	H-V	H-V	H-V	V	V	-	-	-	-	H-V
EJB 10A	H-V	H-V	H-V	V	V	-	-	-	-	H-V
EJB 10B	H-V	H-V	H-V	V	V	-	-	-	-	H-V
EJB 11	H-V	H-V	H-V	H-V	H-V	H-V	V	V	V	H-V
EJB 11A	H-V	H-V	H-V	H-V	H-V	H-V	V	V	V	H-V
EJB 11B	H-V	H-V	H-V	H-V	H-V	H-V	V	V	V	H-V
EJB 12	H-V	H-V	V	-	-	-	V	-	V	V
EJB 13	H-V	H-V	V	-	-	-	V	-	V	H-V
EJB 13A	H-V	H-V	V	-	-	-	V	-	V	H-V
EJB 14	H-V	H-V	H-V	V	-	-	V	-	V	H-V
EJB 14A	H-V	H-V	H-V	V	-	-	V	-	V	H-V
EJB 15	H-V	H-V	H-V	H-V	H-V	H-V	V	V	V	H-V
EJB 15A	H-V	H-V	H-V	H-V	H-V	H-V	V	V	V	H-V
EJB 16	-	-	-	-	-	-	V	-	-	-
EJB 17	H-V	H-V	H-V	H-V	H-V	H-V	H-V	H-V	H-V	H-V
EJB 17A	H-V	H-V	H-V	H-V	H-V	H-V	H-V	H-V	H-V	H-V
EJB 17Q	H-V	H-V	H-V	H-V	H-V	H-V	H-V	H-V	H-V	H-V
EJB 18	H-V	H-V	H-V	H-V	H-V	H-V	H-V	H-V	H-V	H-V
EJB 18A	H-V	H-V	H-V	H-V	H-V	H-V	H-V	H-V	H-V	H-V
EJB 18B	H-V	H-V	H-V	H-V	H-V	H-V	H-V	H-V	H-V	H-V
EJB 19	H-V	H-V	H-V	H-V	H-V	H-V	V	V	V	H-V
EJB 19A	H-V	H-V	H-V	H-V	H-V	H-V	V	V	V	H-V
EJB 20	H-V	H-V	H-V	H-V	H-V	H-V	H-V	H-V	H-V	H-V
EJB 20A	H-V	H-V	H-V	H-V	H-V	H-V	H-V	H-V	H-V	H-V

Release date 2011-01-24 - Updated 2013-04-19 - A5

EJB/WG Window Size

Dimensions [mm]

Glass size	Circular window					
	WGS	WG00	WG0	WG1	WG2/3	WG3L
Ø	50	63	79	121	160	260

Drawing EJB/WG

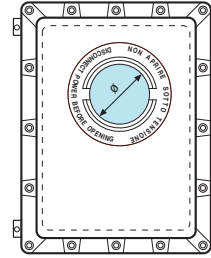

EJB/WG Circular Glass Ubication Table

Type	WGS Ø 50 mm	WG00 Ø 63 mm	WG0 Ø 79 mm	WG1 Ø 121 mm	WG2/3 Ø 160 mm	WG3L Ø 260 mm
EJB 0	-	-	-	-	-	-
EJB 1	1	1	-	-	-	-
EJB 2	1	1	1	-	-	-
EJB 2A	1	1	1	-	-	-
EJB 3	1	-	-	-	-	-
EJB 3A	1	-	-	-	-	-
EJB 4	1	1	1	-	-	-
EJB 4A	1	1	1	-	-	-
EJB 6	1	1	1	-	-	-
EJB 6A	1	1	1	-	-	-
EJB 8	1	1	1	1	-	-
EJB 8A	1	1	1	1	-	-
EJB 8B	1	1	1	1	-	-
EJB 9	1	1	1	-	-	-
EJB 9A	1	1	1	-	-	-
EJB 9B	1	1	1	-	-	-
EJB 10	1	1	1	1	1	-
EJB 10A	1	1	1	1	1	-
EJB 10B	1	1	1	1	1	-
EJB 11	1	1	1	1	1	-
EJB 11A	1	1	1	1	1	-
EJB 11B	1	1	1	1	1	-
EJB 12	1	1	1	1	-	-
EJB 13	1	1	1	1	-	-
EJB 13A	1	1	1	1	-	-
EJB 14	1	1	1	1	1	-
EJB 14A	1	1	1	1	1	-
EJB 15	1	1	1	1	1	1
EJB 15A	1	1	1	1	1	1
EJB 16	1	1	-	-	-	-
EJB 17	1	1	1	1	1	1
EJB 17A	1	1	1	1	1	1
EJB 17Q	1	1	1	1	1	1
EJB 18	1	1	1	1	1	1
EJB 18A	1	1	1	1	1	1
EJB 18B	1	1	1	1	1	1
EJB 19	1	1	1	1	1	-
EJB 19A	1	1	1	1	1	-
EJB 20	1	1	1	1	1	1
EJB 20A	1	1	1	1	1	1

Release date 2011-01-24 – Updated 2013-04-19 - A5

This datasheet does not constitute any contract obligation.

Pepperl+Fuchs reserves the right to modify the products herein illustrated without prior notice. Copyright Pepperl+Fuchs srl - Italy: +39 039 6292 1

EJB/W - Drilling Table

Type	Cover				Body (long side – short side)							
	M12	1/4"	1/2"	1"	1/2"	3/4"	1"	1.1/4"	1.1/2"	2"	2.1/2"	3"
EJB 0	4	4	3	3	5-4	4-3	3-1	2-1	2-1	1-1	-	-
EJB 1	6	6	6	6	6-5	5-4	4-2	2-2	2-1	1-1	-	-
EJB 2	9	9	9	5	4-4	3-3	2-2	-	-	-	-	-
EJB 2A	9	9	9	5	8-8	8-8	5-5	3-3	2-2	2-2	1-1	-
EJB 3	8	8	8	6	7-4	4-2	4-2	3-1	3-1	-	-	-
EJB 3A	8	8	8	6	8-5	8-4	5-3	3-2	3-1	2-1	-	-
EJB 4	20	20	16	9	6-5	5-4	3-3	3-2	2-2	2-1	-	-
EJB 4A	20	20	16	9	8-6	6-5	5-4	5-4	4-3	2-2	-	-
EJB 6	15	15	15	8	9-5	9-5	5-3	4-2	3-2	3-1	-	-
EJB 6A	15	15	15	8	14-8	14-8	8-5	5-3	5-2	3-2	2-1	2-1
EJB 8	20	20	20	12	12-10	12-8	10-6	7-5	5-4	3-2	2-1	2-1
EJB 8A	20	20	20	12	15-11	14-11	10-6	8-5	7-5	3-2	3-2	2-1
EJB 8B	20	20	20	12	17-12	15-12	14-9	11-8	8-6	5-3	3-2	2-1
EJB 9	18	18	18	10	9-5	9-5	6-4	5-4	4-3	3-2	-	-
EJB 9A	18	18	18	10	12-8	12-6	9-6	7-4	5-4	3-2	3-1	2-1
EJB 9B	18	18	18	10	22-12	18-10	12-9	11-5	8-5	6-2	4-2	3-1
EJB 10	20	20	20	16	12-10	12-8	9-7	6-5	5-4	4-3	3-2	-
EJB 10A	20	20	20	16	14-10	14-10	10-8	8-6	7-5	4-3	3-2	2-2
EJB 10B	20	20	20	16	18-12	18-12	15-11	11-8	8-6	5-4	4-3	3-2
EJB 11	28	28	28	24	16-12	16-12	13-9	6-5	5-4	4-3	3-3	-
EJB 11A	28	28	28	24	20-14	20-14	13-10	9-7	7-5	5-4	3-3	3-2
EJB 11B	28	28	28	24	21-18	21-18	17-14	10-8	10-8	7-5	4-3	3-2
EJB 12	20	20	20	16	20-11	20-11	12-8	11-5	7-4	4-2	4-2	3-1
EJB 13	21	21	21	18	23-11	23-11	14-8	11-6	9-5	5-3	4-2	3-2
EJB 13A	21	21	21	18	24-15	24-12	17-9	11-8	11-8	6-4	5-2	3-2
EJB 14	32	32	32	20	18-10	18-10	15-8	8-5	7-4	5-3	4-2	-
EJB 14A	32	32	32	20	27-15	26-14	20-11	12-6	11-5	6-3	4-2	3-2
EJB 15	40	40	40	30	23-17	23-17	14-10	10-8	10-7	5-4	4-3	3-2
EJB 15A	40	40	40	30	24-18	24-18	17-11	12-8	12-8	7-5	5-3	3-3
EJB 16	18	18	18	14	17-5	17-5	9-3	6-2	6-2	4-1	-	-
EJB 17	35	35	35	24	27-21	27-21	20-12	13-10	13-10	7-5	5-4	4-3
EJB 17A	35	35	35	24	32-24	32-24	21-18	18-12	17-11	14-8	8-6	5-5
EJB 17Q	42	42	42	28	30-30	22-22	18-18	17-17	14-14	8-8	7-7	5-5
EJB 18	45	45	45	32	20-14	20-12	16-12	15-10	13-8	7-5	5-3	3-3
EJB 18A	45	45	45	32	30-21	30-21	23-17	20-14	17-9	10-7	6-5	5-3
EJB 18B	45	45	45	32	36-24	36-24	30-18	26-15	18-15	14-11	8-6	8-5
EJB 19	35	35	35	28	20-10	20-10	16-8	13-7	11-5	6-3	5-2	4-2
EJB 19A	35	35	35	28	27-15	27-15	23-11	20-8	14-6	9-5	7-3	5-2
EJB 20	35	35	35	35	20-12	20-12	16-12	16-10	12-10	6-5	4-3	4-2
EJB 20A	35	35	35	35	24-18	24-18	20-15	20-12	12-10	8-6	8-4	8-4

Note: - available cable entry with 1/4" and 3/8" diameter (or other equivalent thread type) with the same maximum number of 1/2" holes.
 - the cable entries with Metric (x 1.5) threads are equivalent in number with the inches threads listed in the above table.
 The comparison between Metric (x 1.5) and inches is according to the below table.

EJB - Threads Comparison Table

Inches	1/4"	3/8"	1/2"	3/4"	1"	1 1/4"	1 1/2"	2"	2 1/2"	3"
Metric (x 1.5)	M12	M16	M20	M25	M32	M40/M42	M50	M63	M75	M85

Release date 2011-01-24 – Updated 2013-04-19 - A5

EJB/W - Bottom Drilling Table

Type	Bottom				
	1/2"	3/4"	1"	1.1/4"	1.1/2"
EJB 0	2	2	1	-	-
EJB 1	2	2	1	-	-
EJB 2	2	2	2	-	-
EJB 2A	2	2	2	-	-
EJB 3	2	2	1	-	-
EJB 3A	2	2	1	-	-
EJB 4	2	2	2	-	-
EJB 4A	2	2	2	-	-
EJB 6	3	3	2	-	-
EJB 6A	3	3	2	-	-
EJB 8	4	4	3	-	-
EJB 8A	4	4	3	-	-
EJB 8B	4	4	3	-	-
EJB 9	4	4	3	-	-
EJB 9A	4	4	3	-	-
EJB 9B	4	4	3	-	-
EJB 10	4	4	3	1	1
EJB 10A	4	4	3	1	1
EJB 10B	4	4	3	1	1
EJB 11	5	5	4	2	2
EJB 11A	5	5	4	2	2
EJB 11B	5	5	4	2	2
EJB 12	4	4	3	1	1
EJB 13	4	4	3	1	1
EJB 13A	4	4	3	1	1
EJB 14	5	5	3	1	1
EJB 14A	5	5	3	1	1
EJB 15	6	6	4	3	2
EJB 15A	6	6	4	3	2
EJB 16	4	4	3	1	1
EJB 17	6	6	5	3	3
EJB 17A	6	6	5	3	3
EJB 17Q	6	6	5	3	3
EJB 18	6	6	5	3	3
EJB 18A	6	6	5	3	3
EJB 18B	6	6	5	3	3
EJB 19	6	6	5	3	3
EJB 19A	6	6	5	3	3
EJB 20	6	6	5	3	3
EJB 20A	6	6	5	3	3

Note: - the cable entries with Metric (x 1.5) threads are equivalent in number with the inches threads listed in the above table.
The comparison between Metric (x 1.5) and inches is according to the below table.

EJB - Threads Comparison Table

Inches	1/4"	3/8"	1/2"	3/4"	1"	1 1/4"	1 1/2"	2"	2 1/2"	3"
Metric (x 1.5)	M12	M16	M20	M25	M32	M40/M42	M50	M63	M75	M85

Release date 2011-01-24 - Updated 2013-04-19 - A5

EJB/W - Mounting Plates

Dimensions [mm]

Enclosure	A	B	C	D	E	F	ØG	type 1	type 2
EJB 0					Not available				
EJB 1	10	20	40	130	145	100	6	X	
EJB 2	10	25	120	130	150	145	7	X	
EJB 2A	10	25	120	130	150	145	7	X	
EJB 3	10	20	37	163	183	85	6		X
EJB 3A	10	20	37	163	183	85	6		X
EJB 4	10	20	68	170	190	145	7	X	
EJB 4A	10	20	68	170	190	145	7	X	
EJB 6	10	20	75	220	235	135	7	X	
EJB 6A	10	20	75	220	235	135	7	X	
EJB 8	10	25	85	275	290	190	7	X	
EJB 8A	10	25	85	275	290	190	7	X	
EJB 8B	10	25	85	275	290	190	7	X	
EJB 9	10	25	70	297	310	145	7	X	
EJB 9A	10	25	70	297	310	145	7	X	
EJB 9B	10	25	70	297	310	145	7	X	
EJB 10	10	25	160	335	355	245	7	X	
EJB 10A	10	25	160	335	355	245	7	X	
EJB 10B	10	25	160	335	355	245	7	X	
EJB 11	15	25	110	365	380	305	7	X	
EJB 11A	15	25	110	365	380	305	7	X	
EJB 11B	15	25	110	365	380	295	7	X	
EJB 12	10	25	165	247	410	180	7	X	
EJB 13	15	25	140	394	410	210	7	X	
EJB 13A	15	25	140	394	410	210	7	X	
EJB 14	15	25	150	460	475	225	7	X	
EJB 14A	15	25	150	460	475	225	7	X	
EJB 15	15	25	280	430	465	315	8		X
EJB 15A	15	25	280	430	465	315	8		X
EJB 16	10	20	55	460	480	100	7	X	
EJB 17	15	25	295	520	540	370	8	X	
EJB 17A	15	25	295	520	540	370	8	X	
EJB 17Q	15	30	253	459	475	475	8	X	
EJB 18	15	30	203	585	600	390	8	X	
EJB 18A	15	30	203	585	600	390	8	X	
EJB 18B	15	30	235	585	605	400	8	X	
EJB 19	15	30	103	605	620	265	8	X	
EJB 19A	15	30	103	605	620	265	8	X	
EJB 20	25	30	375	730	750	500	8	X	
EJB 20A	25	30	375	730	750	500	8	X	

EJB - Mounting Plates in galvanized steel, thickness 20/10 mm

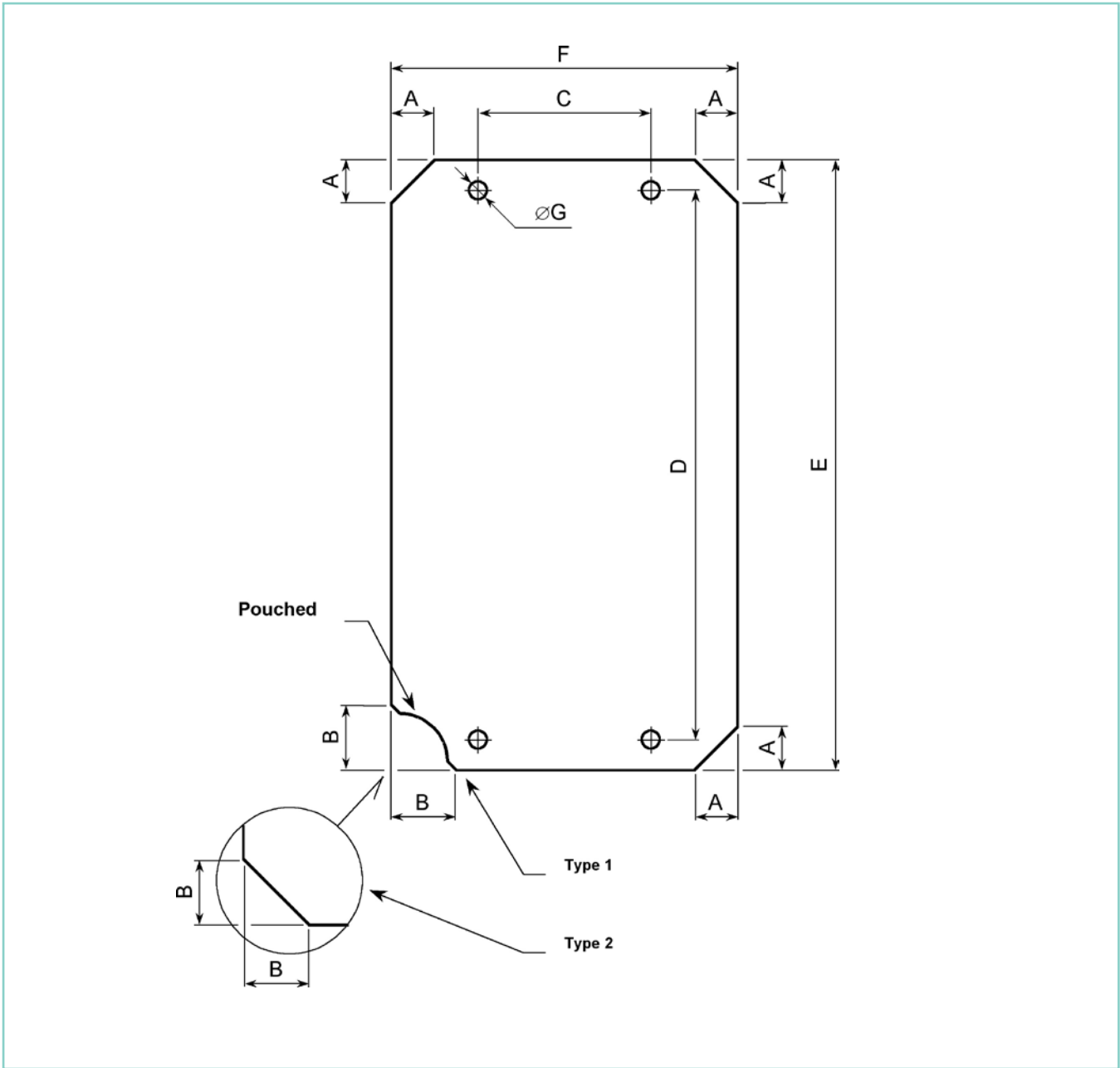

Note: the positioning of the mounting plate reported here above is purely as an example, the location of the earth screw depends on the type of enclosure.

Release date 2011-01-24 – Updated 2013-04-19 - A5

Description:

The EJB/X enclosures are made of stainless steel. They are rectangular shaped and complete with a flat joint cover, which is fixed by hexagonal head screws.

The stainless steel enclosures (EJB/X/W) can install the same type of rectangular thermo-resistant tempered glass window.

Application:

The enclosures are suitable to contain terminals, contactors, switches, transformers, capacitors, PLC and other electric, electronic equipments and I.S. devices.

Materials:

Body and cover: stainless steel AISI 316L.

Screws: stainless steel.

Welded brackets: stainless steel.

Windows: thermo-resistant tempered glass.

Certification characteristics:

Type of Protection: II 2GD Ex d IIB Gb / Ex tb IIIC Db

II 2GD Ex d [i. G.] IIB T6 Gb / Ex tb [i.D] IIIC T85°C Db.

Class of Temperature: T6/T85 °C → T3/T200 °C.

Protection Degree: IP66 / IP67*.

Certificate: INERIS 10ATEX0035X.

Ambient Temp.: -20 °C / +60 °C (+40 / +50 / +55 °C).

Zones: 1 – 21 – 2 – 22.

Threads:

NPT (ANSI B1.20.1).

Metric x1.5 (ISO 261).

On request:

AISI 304 version.

*IP67 protection with o-ring.

Stainless steel hinges.

Galvanized or stainless steel equipment plate.

Pushbuttons, pilot light, selector switches.

Breathing / draining valve.

Wiring.

Special inhibiting treatment.

Cable glands for armoured or non armoured cable.

Drawing EJB/X

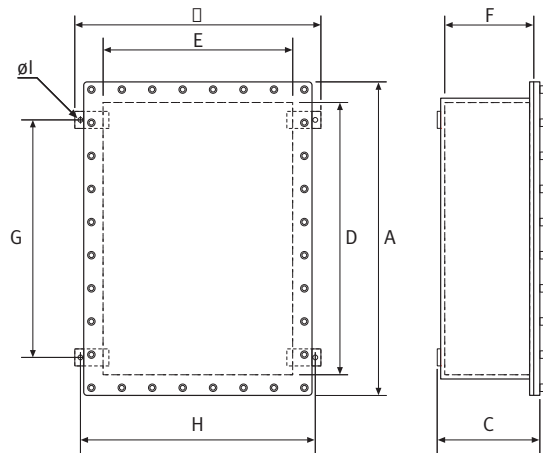

Drawing EJB/X/W

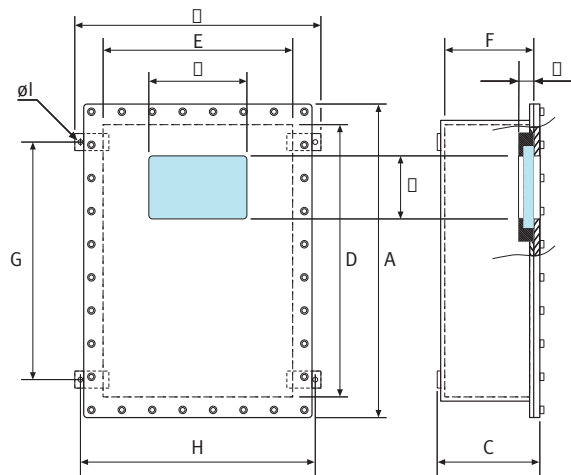

Legend:

- A - Maximum external dimension.
- B - Maximum external dimension with mounting brackets.
- C - Maximum external dimension with cover.
- D - Internal dimension.
- E - Internal dimension.
- F - Internal depth.
- G - Fixing holes wheel base.
- H - Fixing holes wheel base.
- Ø I - Fixing holes diameter.
- X - Window Dimension.
- Y - Window Dimension.
- S - Chassis internal thickness.

EJB/X - Data Table

Dimensions [mm] and approx. Weight [Kg]

Type	Dimensions						Fixing			Weight
	External			Internal			G	H	Ø I	
	A	B	C	D	E	F				
EJB/X 0	190	128	141	140	75	120	133	108	8	7
EJB/X 1	213	178	141	155	115	120	148	158	8	9,5
EJB/X 2	218	226	86	160	160	65	157	206	8	10
EJB/X 2A	218	226	156	160	160	135	157	206	8	12
EJB/X 3	250	165	121	200	100	100	185	145	8	10
EJB/X 3A	250	165	156	200	100	135	185	145	8	11
EJB/X 4	256	226	140	200	160	115	188	206	8	15,5
EJB/X 4A	256	226	180	200	160	155	188	206	8	17
EJB/X 5	260	195	121	200	130	100	178	175	8	12
EJB/X 6	308	216	135	250	150	110	233	196	8	17,5
EJB/X 6A	308	216	170	250	150	145	230	196	8	19
EJB/X 8	368	270	175	300	200	150	282	250	10	27
EJB/X 8A	368	270	197	300	200	170	282	250	10	33
EJB/X 8B	368	270	232	300	200	205	282	250	10	36
EJB/X 9	386	226	150	330	160	125	280	206	10	23
EJB/X 9A	386	226	180	330	160	155	280	206	10	25
EJB/X 9B	386	226	257	330	160	230	316	206	10	37
EJB/X 10	448	350	157	370	260	130	345	320	10	42
EJB/X 10A	448	350	208	370	260	180	345	320	10	46,5
EJB/X 10B	448	350	268	370	260	235	345	320	10	66
EJB/X 11	486	415	178	400	320	150	363	385	10	55
EJB/X 11A	486	415	223	400	320	190	363	385	10	73
EJB/X 11B	486	415	273	400	320	240	363	385	10	80
EJB/X 12	498	275	173	430	195	145	404	245	10	40
EJB/X 13	506	318	208	430	230	180	398	290	10	49
EJB/X 13A	506	318	263	430	230	230	398	290	10	67
EJB/X 14	576	336	168	500	250	140	473	306	10	53
EJB/X 14A	576	336	228	500	250	195	473	306	10	73
EJB/X 15	576	460	223	500	350	190	462	430	12	89
EJB/X 15A	576	460	265	500	350	230	462	430	12	96
EJB/X 15B	576	460	145	500	350	110	462	430	12	75
EJB/X 16	577	178	125	515	120	100	502	158	10	32
EJB/X 17	660	494	245	570	400	210	550	464	14	130
EJB/X 17A	660	494	360	570	400	325	550	464	14	145
EJB/X 17Q	590	640	315	500	500	280	395	595	14	143
EJB/X 18	732	535	205	640	430	170	590	505	14	133
EJB/X 18A	732	535	265	640	430	230	590	505	14	145
EJB/X 18B	732	535	365	640	430	330	590	505	14	167
EJB/X 19	726	384	185	650	300	150	610	354	14	97
EJB/X 19A	726	384	255	650	300	220	610	354	14	110
EJB/X 20	920	670	307	800	550	260	697	630	16	268
EJB/X 20A	920	670	437	800	550	390	697	630	16	316

All Enclosures are available with o-ring for IP67 protection degree.
For IP67 protection degree, the dimensions "A" and "B" will be slightly more than standard version (IP66).

Release date 2011-01-24 – Updated 2013-04-19 - A5

EJB/X/W Window Size

Dimensions [mm]

Glass size	Rectangular windows			
	W0	W1	W2A	W7
X	75	105	180	120
Y	75	75	40	108
S	22	22	22	35

** For obtaining the useful depth of the enclosures, the size "S" must be deducted from the size "F".

Drawing EJB/X/W

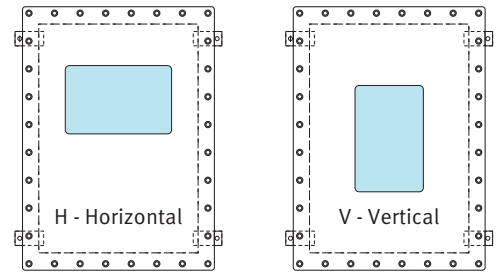

EJB/X/W Rectangular Glass Ubication Table

Type	W0 75 x 75 mm	W1 105 x 75 mm	W2A 180 x 40 mm	W7 120 x 108 mm
EJB/X 0	-	-	-	-
EJB/X 1	-	-	-	-
EJB/X 2	H-V	-	-	-
EJB/X 2A	H-V	-	-	-
EJB/X 3	-	-	-	-
EJB/X 3A	-	-	-	-
EJB/X 4	H-V	V	-	-
EJB/X 4A	H-V	V	-	-
EJB/X 5	-	-	-	-
EJB/X 6	H-V	V	-	-
EJB/X 6A	H-V	V	-	-
EJB/X 8	H-V	H-V	-	H-V
EJB/X 8A	H-V	H-V	-	H-V
EJB/X 8B	H-V	H-V	-	H-V
EJB/X 9	H-V	V	-	-
EJB/X 9A	H-V	V	-	-
EJB/X 9B	H-V	V	-	-
EJB/X 10	H-V	H-V	V	H-V
EJB/X 10A	H-V	H-V	V	H-V
EJB/X 10B	H-V	H-V	V	H-V
EJB/X 11	H-V	H-V	H-V	H-V
EJB/X 11A	H-V	H-V	H-V	H-V
EJB/X 11B	H-V	H-V	H-V	H-V
EJB/X 12	H-V	H-V	-	V
EJB/X 13	H-V	H-V	-	H-V
EJB/X 13A	H-V	H-V	-	H-V
EJB/X 14	H-V	H-V	V	H-V
EJB/X 14A	H-V	H-V	V	H-V
EJB/X 15	H-V	H-V	H-V	H-V
EJB/X 15A	H-V	H-V	H-V	H-V
EJB/X 15B	H-V	H-V	H-V	H-V
EJB/X 16	-	-	-	-
EJB/X 17	H-V	H-V	H-V	H-V
EJB/X 17A	H-V	H-V	H-V	H-V
EJB/X 17Q	H-V	H-V	H-V	H-V
EJB/X 18	H-V	H-V	H-V	H-V
EJB/X 18A	H-V	H-V	H-V	H-V
EJB/X 18B	H-V	H-V	H-V	H-V
EJB/X 19	H-V	H-V	H-V	H-V
EJB/X 19A	H-V	H-V	H-V	H-V
EJB/X 20	H-V	H-V	H-V	H-V
EJB/X 20A	H-V	H-V	H-V	H-V

Release date 2011-01-24 – Updated 2013-04-19 - A5

This datasheet does not constitute any contract obligation.

Pepperl+Fuchs reserves the right to modify the products herein illustrated without prior notice. Copyright Pepperl+Fuchs srl - Italy: +39 039 6292 1

Pepperl+Fuchs Group
www.pepperl-fuchs.com

USA: +1 330 486 0002
pa-info@us.pepperl-fuchs.com

Germany: +49 621 776 2222
pa-info@de.pepperl-fuchs.com

Singapore: +65 6779 9091
pa-info@sg.pepperl-fuchs.com

PEPPERL+FUCHS
PROTECTING YOUR PROCESS

EJB/X - Drilling Table

Type	Cover				Body (long side – short side)								
	M12	1/4"	1/2"	1"	1/2"	3/4"	1"	1.1/4"	1.1/2"	2"	2.1/2"	3"	
EJB/X 0	4	4	3	3	5-4	4-3	3-1	2-1	2-1	1-1	-	-	
EJB/X 1	6	6	6	6	6-5	5-4	4-2	2-2	2-1	1-1	-	-	
EJB/X 2	9	9	9	5	4-4	3-3	2-2	-	-	-	-	-	
EJB/X 2A	9	9	9	5	8-8	8-8	5-5	3-3	2-2	2-2	1-1	-	
EJB/X 3	8	8	8	6	7-4	4-2	4-2	3-1	3-1	-	-	-	
EJB/X 3A	8	8	8	6	8-5	8-4	5-3	3-2	3-1	2-1	-	-	
EJB/X 4	20	20	16	9	6-5	5-4	3-3	3-2	2-2	2-1	-	-	
EJB/X 4A	20	20	16	9	8-6	6-5	5-4	5-4	4-3	2-2	-	-	
EJB/X 5	12	12	12	8	9-5	7-4	4-2	3-2	3-2	-	-	-	
EJB/X 6	15	15	15	8	9-5	9-5	5-3	4-2	3-2	3-1	-	-	
EJB/X 6A	15	15	15	8	14-8	14-8	8-5	5-3	5-2	3-2	2-1	2-1	
EJB/X 8	20	20	20	12	12-10	12-8	10-6	7-5	5-4	3-2	2-1	2-1	
EJB/X 8A	20	20	20	12	15-11	14-11	10-6	8-5	7-5	3-2	3-2	2-1	
EJB/X 8B	20	20	20	12	17-12	15-12	14-9	11-8	8-6	5-3	3-2	2-1	
EJB/X 9	18	18	18	10	9-5	9-5	6-4	5-4	4-3	3-2	-	-	
EJB/X 9A	18	18	18	10	12-8	12-6	9-6	7-4	5-4	3-2	3-1	2-1	
EJB/X 9B	18	18	18	10	22-12	18-10	12-9	11-5	8-5	6-2	4-2	3-1	
EJB/X 10	20	20	20	16	12-10	12-8	9-7	6-5	5-4	4-3	3-2	-	
EJB/X 10A	20	20	20	16	14-10	14-10	10-8	8-6	7-5	4-3	3-2	2-2	
EJB/X 10B	20	20	20	16	18-12	18-12	15-11	11-8	8-6	5-4	4-3	3-2	
EJB/X 11	28	28	28	24	16-12	16-12	13-9	6-5	5-4	4-3	3-3	-	
EJB/X 11A	28	28	28	24	20-14	20-14	13-10	9-7	7-5	5-4	3-3	3-2	
EJB/X 11B	28	28	28	24	21-18	21-18	17-14	10-8	10-8	7-5	4-3	3-2	
EJB/X 12	20	20	20	16	20-11	20-11	12-8	11-5	7-4	4-2	4-2	3-1	
EJB/X 13	21	21	21	18	23-11	23-11	14-8	11-6	9-5	5-3	4-2	3-2	
EJB/X 13A	21	21	21	18	24-15	24-12	17-9	11-8	11-8	6-4	5-2	3-2	
EJB/X 14	32	32	32	20	18-10	18-10	15-8	8-5	7-4	5-3	4-2	-	
EJB/X 14A	32	32	32	20	27-15	26-14	20-11	12-6	11-5	6-3	4-2	3-2	
EJB/X 15	40	40	40	30	23-17	23-17	14-10	10-8	10-7	5-4	4-3	3-2	
EJB/X 15A	40	40	40	30	24-18	24-18	17-11	12-8	12-8	7-5	5-3	3-3	
EJB/X 15B	40	40	40	30	14-10	14-10	10-6	7-5	6-4	-	-	-	
EJB/X 16	18	18	18	14	17-5	17-5	9-3	6-2	6-2	4-1	-	-	
EJB/X 17	35	35	35	24	27-21	27-21	20-12	13-10	13-10	7-5	5-4	4-3	
EJB/X 17A	35	35	35	24	32-24	32-24	21-18	18-12	17-11	14-8	8-6	5-5	
EJB/X 17Q	42	42	42	28	30-30	22-22	18-18	17-17	14-14	8-8	7-7	5-5	
EJB/X 18	45	45	45	32	20-14	20-12	16-12	15-10	13-8	7-5	5-3	3-3	
EJB/X 18A	45	45	45	32	30-21	30-21	23-17	20-14	17-9	10-7	6-5	5-3	
EJB/X 18B	45	45	45	32	36-24	36-24	30-18	26-15	18-15	14-11	8-6	8-5	
EJB/X 19	35	35	35	28	20-10	20-10	16-8	13-7	11-5	6-3	5-2	4-2	
EJB/X 19A	35	35	35	28	27-15	27-15	23-11	20-8	14-6	9-5	7-3	5-2	
EJB/X 20	60	60	60	60	60-40	50-34	36-24	16-10	12-10	6-5	4-3	4-2	
EJB/X 20A	60	60	60	60	102-67	78-54	60-40	20-12	12-10	8-6	8-4	8-4	

Note: - cable entry holes are realized by welded coupling
 - available cable entry with 1/4" and 3/8" diameter (or other equivalent thread type) with the same maximum number of 1/2" holes.
 - the cable entries with Metric (x 1.5) threads are equivalent in number with the inches threads listed in the above table.
 The comparison between Metric (x 1.5) and inches is according to the below table.

EJB - Threads Comparison Table

Inches	1/4"	3/8"	1/2"	3/4"	1"	1 1/4"	1 1/2"	2"	2 1/2"	3"
Metric (x 1.5)	M12	M16	M20	M25	M32	M40/M42	M50	M63	M75	M85

Release date 2011-01-24 – Updated 2013-04-19 - A5

EJB/X - Mounting Plates

Dimensions [mm]

Enclosure	A	B	C	D	E	F	ØG	type 1	type 2
EJB/X 0	Not available								
EJB/X 1	10	20	40	130	145	100	6	X	
EJB/X 2	10	25	120	130	150	145	7	X	
EJB/X 2A	10	25	120	130	150	145	7	X	
EJB/X 3	10	20	37	163	183	85	6		X
EJB/X 3A	10	20	37	163	183	85	6		X
EJB/X 4	10	20	68	170	190	145	7	X	
EJB/X 4A	10	20	68	170	190	145	7	X	
EJB/X 5	10	20	70	180	200	120	7	X	
EJB/X 6	10	20	75	220	235	135	7	X	
EJB/X 6A	10	20	75	220	235	135	7	X	
EJB/X 8	10	25	85	275	290	190	7	X	
EJB/X 8A	10	25	85	275	290	190	7	X	
EJB/X 8B	10	25	85	275	290	190	7	X	
EJB/X 9	10	25	77	297	310	145	7	X	
EJB/X 9A	10	25	77	297	310	145	7	X	
EJB/X 9B	10	25	77	297	310	145	7	X	
EJB/X 10	10	25	160	335	355	245	7	X	
EJB/X 10A	10	25	160	335	355	245	7	X	
EJB/X 10B	10	25	160	335	355	245	7	X	
EJB/X 11	15	25	110	365	380	295	7	X	
EJB/X 11A	15	25	110	365	380	295	7	X	
EJB/X 11B	15	25	110	365	380	295	7	X	
EJB/X 12	10	25	165	247	410	180	7	X	
EJB/X 13	15	25	140	394	410	210	7	X	
EJB/X 13A	15	25	140	394	410	210	7	X	
EJB/X 14	15	25	150	460	475	225	7	X	
EJB/X 14A	15	25	150	460	475	225	7	X	
EJB/X 15	15	25	290	440	475	325	8		X
EJB/X 15A	15	25	290	440	475	325	8		X
EJB/X 15B	15	25	290	440	475	325	8		X
EJB/X 16	10	20	55	460	480	100	7	X	
EJB/X 17	15	25	295	520	540	370	8	X	
EJB/X 17A	15	25	295	520	540	370	8	X	
EJB/X 17Q	15	30	253	459	475	475	8	X	
EJB/X 18	15	30	235	585	600	390	8	X	
EJB/X 18A	15	30	235	585	600	390	8	X	
EJB/X 18B	15	30	235	585	605	400	8	X	
EJB/X 19	15	30	103	605	620	265	8	X	
EJB/X 19A	15	30	103	605	620	265	8	X	
EJB/X 20	25	30	375	730	750	500	8	X	
EJB/X 20A	25	30	375	730	750	500	8	X	

EJB - Mounting Plates in galvanized steel, thickness 20/10 mm

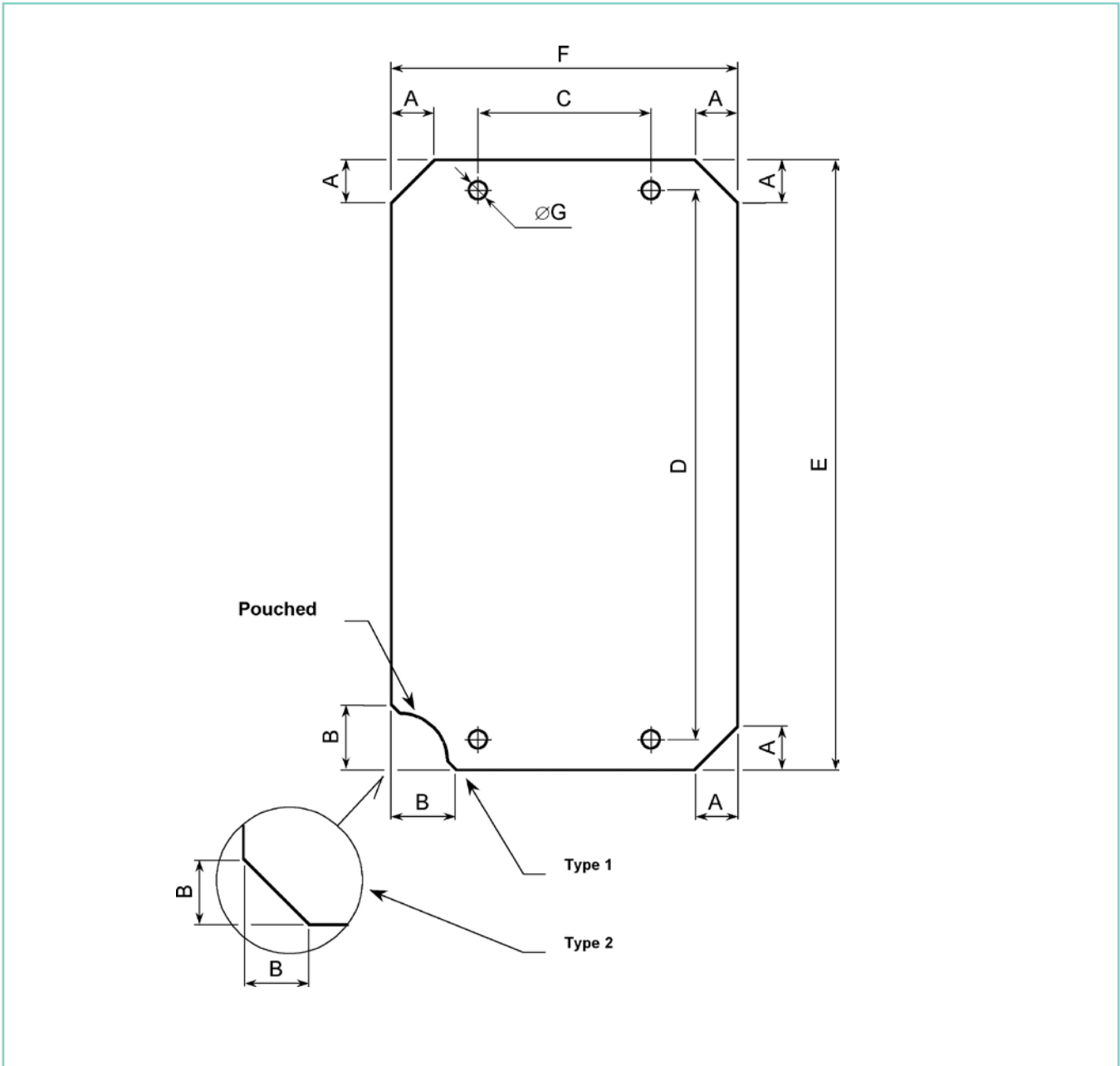

Note: the positioning of the mounting plate reported here above is purely as an example, the location of the earth screw depends on the type of enclosure.

Release date 2011-01-24 – Updated 2013-04-19 - A5

ASM/CI - Enclosure with flanged cover in cast iron

Description:

The ASM/CI range comprises of three flameproof enclosures manufactured from cast iron. Enclosure bodies are fitted with flat hinged cover for mounting of operators or viewing windows as required.

Application:

ASM/CI enclosures can be customized to suit the needs of your specification. Typical applications are terminal junction boxes, control junction boxes and engineered solutions. Many safe area components can be installed inside the enclosures.

Materials:

Body: Cast iron.
Screws: Stainless steel.
For details see data tables overleaf.

Certification characteristics:

Marking to 94/9/EC: II 2GD
Zones: 1 – 21 – 2 – 22

For type of protection, certificates, ambient temperature ranges and ingress protection please see data tables overleaf.

Threads:

Metric threaded.

Inhibiting treatments:

Zinc rich epoxy powder primer plus epoxy powder top coat black.

Features:

Enclosure cover: hinged non-detachable
Mounting: 2 x fabricated stainless steel mounting straps.

Drawing ASM

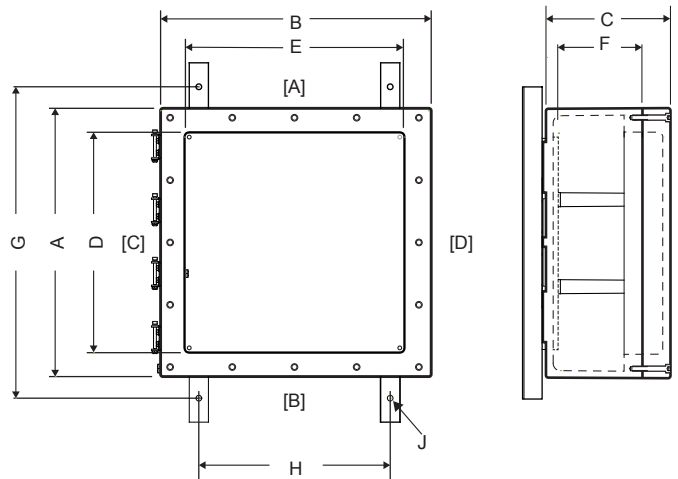

Legend:

- A - Maximum external dimension.
- B - Maximum external dimension.
- C - Maximum external dimension.
- D - Internal dimension.
- E - Internal dimension.
- F - Internal depth.
- G - Fixing holes wheel base.
- H - Fixing holes wheel base.
- J - Fixing holes diameter.
- [A] - Entry face.
- [B] - Entry face.

For details see Dimensions Data Table.

Enclosure types:

For drawing references, dimensions [mm] and approx. weight [kg] see Dimensions Data Table.

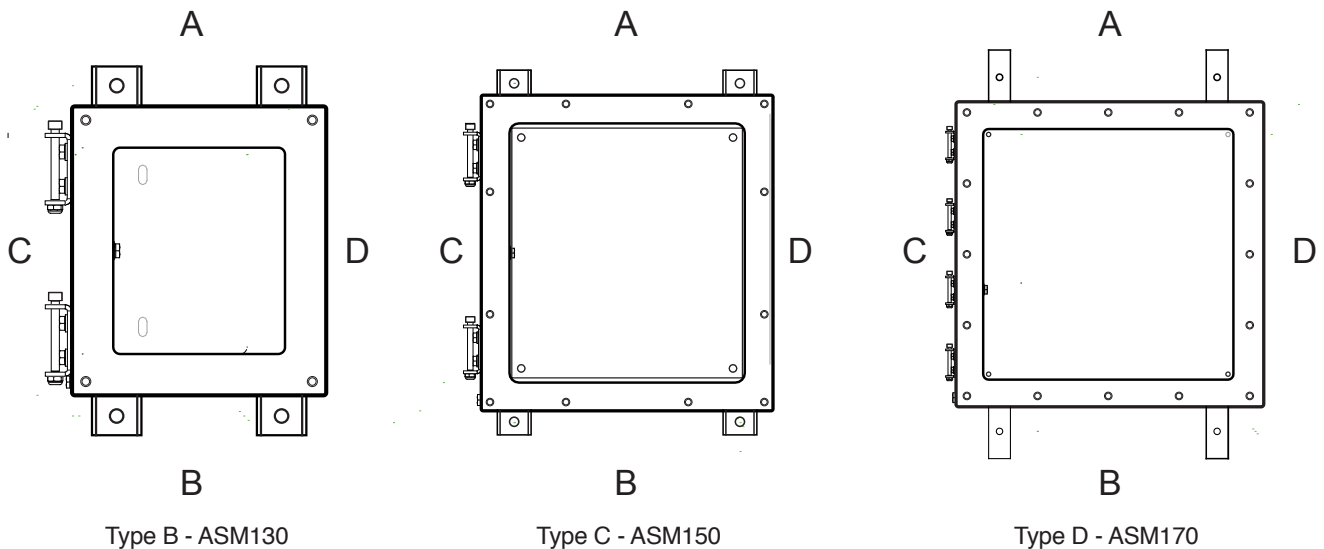

Release date 2013-03-20 - A0

ASM/CI - Dimensions Data Table

Type	Dimensions external [mm]			Dimensions internal [mm]			Fixation [mm]			Enclosure material	Weight approx. [kg]	Drawing reference see *1*
	A	B	C	D	E	F	G	H	Diam. J			
ASM130/CI	210	185	156	150	125	85	240	120	9.1	cast iron	20	B
ASM150/CI	335	310	205	275	250	133	360	240	10.3	cast iron	50	C
ASM170/CI	560	560	266	460	460	174	650	400	10.3	cast iron	172	D

1 Reference drawings see at preceeding page

ASM/CI - Mechanical Specification

Type	Number of rails		Usable length per rail [mm]		Max. power dissipation [W]	Grounding see *2*	Cover fixing screws Stainless steel	Ingress protection EN60529	Seal see *1*
	vertical	horizontal	vertical	horizontal					
ASM130/CI	1	1	120	tbc	7	1	M8	IP66	2
ASM150/CI	2	2	245	tbc	62	1	M8	IP66	2
ASM170/CI	4	4	436	436	200	2	M10	IP66	2

1 Seal:

2 - One piece closed cell neoprene.

2 Grounding:

1 - base: internal and external M6 grounding point, cover: internal M6 grounding point.

2 - base: internal and external M10 grounding point, cover: internal M10 grounding point.

ASM/CI - Drilling Table

Type	Entries Face A					Entries Face B					Entries Face C					Entries Face D				
	M16	M20	M25	M32	M40	M16	M20	M25	M32	M40	M16	M20	M25	M32	M40	M16	M20	M25	M32	M40
ASM130/CI	5	5	5	2	2	5	5	5	2	2	7	5	5	3	2	7	5	5	3	2
ASM150/CI	11	11	8	7	3	11	11	8	7	3	11	11	8	7	3	11	11	8	7	3
ASM170/CI	12	12	12	6	6	12	12	12	6	6	12	12	12	6	6	12	12	12	6	6

Note: NPT, PG and ET threads available on request.

Max. quantity per gland size. For combination of different gland sizes please contact Pepperl+Fuchs.

ASM/CI - Certification characteristics

Marking to 94/9/EC

II 2 GD

Type of protection

- 1.1 Ex d IIB T5 Gb, Ex tb IIIC T82 °C Db (ta ... +55 °C)
- 1.2 Ex d IIB T5 Gb, Ex tb IIIC T87 °C Db (ta ... +55 °C)
- 1.3 Ex d IIB T5 Gb, Ex tb IIIC T95 °C (ta ... +55 °C)
- 1.4 Ex d IIB T6 Gb, Ex tb IIIC T76 °C Db (ta ... +50 °C)
- 1.5 Ex d IIB T6 Gb, Ex tb IIIC T80 °C (ta ... +40 °C)

Certificate

- 2.2 SIRA 03 ATEX 1215
- 2.3 SIRA 04 ATEX 1266X
- 2.4 SIRA 04 ATEX 1267X

Ambient temperature

- 3.1 -20 ... 55 °C (-4 ... 131 °F)
- 3.2 -40 ... 55 °C (-40 ... 131 °F)

IECEX approval

- 4.1 IECEX SIR 08.0055
- 4.2 IECEX SIR 08.0056X
- 4.3 IECEX SIR 08.0057X

GOST-R approval

- 5.2 GOST-R B01008

ASM/CI - Certification cross-reference

for certification characteristics please see table above

Type	Type of protection	Certification	Ambient temperature	IECEX	GOST-R
	see (1)	see (2)		see (4)	see (5)
ASM130/CI	1.3, 1.5	2.2	-20 ... 55 °C (-4 ... 131 °F)	4.1	5.2
ASM150/CI	1.1, 1.4	2.3	-40 ... 55 °C (-40 ... 131 °F)	4.2	5.2
ASM170/CI	1.2	2.4	-40 ... 55 °C (-40 ... 131 °F)	4.3	5.2



SD RANGE AND SF RANGE



Switch disconnectors and fused switch disconnectors
manufactured in cast iron, aluminium or stainless steel

▶ P. 35-43

DOL RANGE AND DOLSD RANGE



Direct online motor starters with or without switch disconnectors
manufactured in cast iron, aluminium or stainless steel

▶ P. 47-55

SDS RANGE



Star-delta motor starters manufactured in cast iron,
aluminium or stainless steel

▶ P. 57-59

This datasheet does not constitute any contract obligation.

Pepperl+Fuchs reserves the right to modify the products herein illustrated without prior notice. Copyright Pepperl+Fuchs srl - Italy: +39 039 6292 1
 Pepperl+Fuchs Group USA: +1 330 486 0002 Germany: +49 621 776 2222 Singapore: +65 6779 9091
 www.pepperl-fuchs.com pa-info@us.pepperl-fuchs.com pa-info@de.pepperl-fuchs.com pa-info@sg.pepperl-fuchs.com

PEPPERL+FUCHS
PROTECTING YOUR PROCESS



Description:

The SD range of switch disconnectors and SF range of fused switch disconnectors are safely protected in flameproof enclosures. Versions are available with various switching currents and pole numbers as well as several fused variants.

Application:

The SD and SF ranges of switch disconnectors are designed for safe operation of high-power electrical circuits in gas or dust explosion hazardous areas.

Materials:

Body: Cast iron, aluminium and stainless steel.
Screws: Stainless steel.
For details see data tables overleaf.

Certification characteristics:

Marking to 94/9/EC: II 2GD
Zones: 1 – 21 – 2 – 22

For type of protection, certificates, ambient temperature ranges and ingress protection please see data tables overleaf.

Threads:

Metric threaded, for details see Mechanical Specification.

Inhibiting treatments:

Zinc rich epoxy powder primer plus epoxy powder top coat black.

Features:

Labeling: OFF – ON
Operator lock: Padlockable in OFF position
Enclosure cover: hinged non-detachable
Mounting: 2 x fabricated stainless steel mounting straps.

Drawing

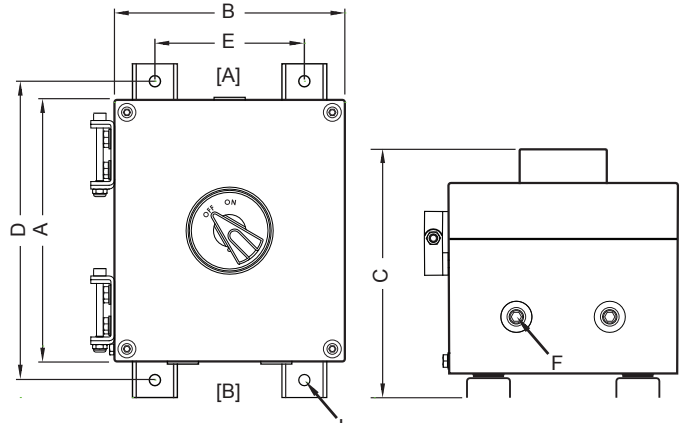

Legend:

- A - Maximum external dimension.
- B - Maximum external dimension.
- C - Maximum external dimension.
- D - Fixing holes wheel base.
- E - Fixing holes wheel base.
- F - Cable entry diameter.
- J - Fixing holes diameter.
- [A] - Entry face.
- [B] - Entry face.

For details see Dimensions Data Table.

Enclosure types:

For drawing references, dimensions [mm] and approx. weight [kg] see Dimensions Data Table.

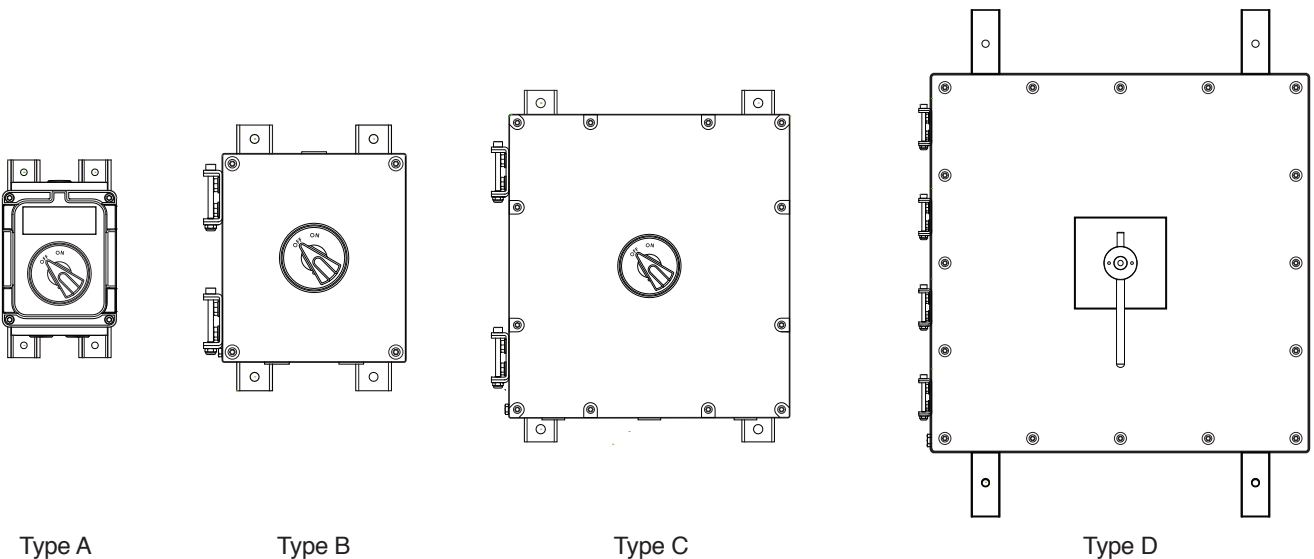

Release date 2013-03-20 - A0

SD/SF - Electrical Specification

Type	Current [A]	Poles qty.	Voltage [V]	Power AC23A [kW]	Power AC3 [kW]	Terminal capacity [mm ²]	Fuse rating see *1*	Enclosure material
SD204	20	4	380 - 440	11	7.5	6	-	cast iron
SFA204	20	4	380 - 440	5.5	3.7	2.5	20 A (SS)	cast aluminium
SFI204	20	4	380 - 440	5.5	3.7	2.5	20 A (SS)	cast iron
SFS204	20	4	380 - 440	5.5	3.7	2.5	20 A (SS)	cast stainless steel
SDA206	20	6	690	11	7.5	6	-	cast aluminium
SDI206	20	6	690	11	7.5	6	-	cast iron
SDSS206	20	6	690	11	7.5	6	-	cast stainless steel
SD254	25	4	380 - 440	11	7.5	6	-	cast iron
SDA256	25	6	690	11	7.5	6	-	cast aluminium
SDI256	25	6	690	11	7.5	6	-	cast iron
SDSS256	25	6	690	11	7.5	6	-	cast stainless steel
SD324	32	4	380 - 440	11	7.5	6	-	cast iron
SFA324	32	4	380 - 440	11	7.5	6	32 A (NS)	cast aluminium
SFI324	32	4	380 - 440	11	7.5	6	32 A (NS)	cast iron
SFS324	32	4	380 - 440	11	7.5	6	32 A (NS)	cast stainless steel
SDA326	32	6	690	11	7.5	6	-	cast aluminium
SDI326	32	6	690	11	7.5	6	-	cast iron
SDSS326	32	6	690	11	7.5	6	-	cast stainless steel
SD404	40	4	380 - 440	22	18.5	16	-	cast iron
SD634	63	4	380 - 440	22	18.5	16	-	cast iron
SFA634	63	4	380 - 440	22	18.5	16	63 A (ES)	cast aluminium
SFI634	63	4	380 - 440	22	18.5	16	63 A (ES)	cast iron
SFS634	63	4	380 - 440	22	18.5	16	63 A (ES)	cast stainless steel
SDA636	63	6	690	22	18.5	16	-	cast aluminium
SDI636	63	6	690	22	18.5	16	-	cast iron
SDSS636	63	6	690	22	18.5	16	-	cast stainless steel
SDA804	80	4	690	37	30	50	-	cast aluminium
SDI804	80	4	690	37	30	50	-	cast iron
SDSS804	80	4	690	37	30	50	-	cast stainless steel
SDA806	80	6	690	30	22	50	-	cast aluminium
SDI806	80	6	690	30	22	50	-	cast iron
SDSS806	80	6	690	30	22	50	-	cast stainless steel
SDA1004	100	4	690	37	30	50	-	cast aluminium
SDI1004	100	4	690	37	30	50	-	cast iron
SDSS1004	100	4	690	37	30	50	-	cast stainless steel
SDA1006	100	6	690	37	30	50	-	cast aluminium
SDI1006	100	6	690	37	30	50	-	cast iron
SDSS1006	100	6	690	37	30	50	-	cast stainless steel
SDA1254	125	4	690	45	37	95	-	cast aluminium
SDI1254	125	4	690	45	37	95	-	cast iron
SDSS1254	125	4	690	45	37	95	-	cast stainless steel
SFA1254	125	4	380 - 440	45	37	70	125 A (XS)	cast aluminium
SFI1254	125	4	380 - 440	45	37	70	125 A (XS)	cast iron
SFS1254	125	4	380 - 440	45	37	70	125 A (XS)	cast stainless steel
SDA1256	125	6	690	45	37	95	-	cast aluminium
SDI1256	125	6	690	45	37	95	-	cast iron
SDSS1256	125	6	690	45	37	95	-	cast stainless steel
SDA1604	160	4	690	55	45	95	-	cast aluminium
SDI1604	160	4	690	55	45	95	-	cast iron
SDSS1604	160	4	690	55	45	95	-	cast stainless steel
SDA1606	160	6	690	55	45	95	-	cast aluminium
SDI1606	160	6	690	55	45	95	-	cast iron
SDSS1606	160	6	690	55	45	95	-	cast stainless steel

Table continues overleaf

Release date 2013-03-20 - AO

This datasheet does not constitute any contract obligation.

Pepperl+Fuchs reserves the right to modify the products herein illustrated without prior notice. Copyright Pepperl+Fuchs srl - Italy: +39 039 6292 1

SD/SF - Electrical Specification continued

Type	Current [A]	Poles qty.	Voltage [V]	Power AC23A [kW]	Power AC3 [kW]	Terminal capacity [mm ²]	Fuse rating see *1*	Enclosure material
SDA2004	200	4	690	75	55	185	-	cast aluminium
SDI2004	200	4	690	75	55	185	-	cast iron
SDSS2004	200	4	690	75	55	185	-	cast stainless steel
SDA2006	200	6	690	75	55	185	-	cast aluminium
SDI2006	200	6	690	75	55	185	-	cast iron
SDSS2006	200	6	690	75	55	185	-	cast stainless steel
SDA2504	250	4	690	90	55	185	-	cast aluminium
SDI2504	250	4	690	90	55	185	-	cast iron
SDSS2504	250	4	690	90	55	185	-	cast stainless steel
SDA2506	250	6	690	90	55	185	-	cast aluminium
SDI2506	250	6	690	90	55	185	-	cast iron
SDSS2506	250	6	690	90	55	185	-	cast stainless steel
SDA3154	315	4	690	110	75	185	-	cast aluminium
SDI3154	315	4	690	110	75	185	-	cast iron
SDSS3154	315	4	690	110	75	185	-	cast stainless steel
SDA3156	315	6	690	110	75	185	-	cast aluminium
SDI3156	315	6	690	110	75	185	-	cast iron
SDSS3156	315	6	690	110	75	185	-	cast stainless steel

Auxiliary contacts: 2 x n/o early break

Grounding: Internal & external brass grounding terminals on base and lid

1 Fused Disconnector versions: Fuse holders ASTA type test certified to BS 88: parts 1 & 6
Fuse breaking capacity 80 kA

SD/SF - Certification characteristics**Marking to 94/9/EC**

II 2 GD

Type of protection

- 1.1 Ex d IIB T5 Gb, Ex tb IIIC T82 °C Db (ta ... +55 °C)
- 1.2 Ex d IIB T5 Gb, Ex tb IIIC T87 °C Db (ta ... +55 °C)
- 1.3 Ex d IIB T5 Gb, Ex tb IIIC T95 °C (ta ... +55 °C)
- 1.4 Ex d IIB T6 Gb, Ex tb IIIC T76 °C Db (ta ... +50 °C)
- 1.5 Ex d IIB T6 Gb, Ex tb IIIC T80 °C (ta ... +40 °C)
- 1.6 Ex d IIB T6 Gb, Ex tb IIIC T85 °C Db

Certificate

- 2.1 SIRA 02 ATEX 1332
- 2.2 SIRA 03 ATEX 1215
- 2.3 SIRA 04 ATEX 1266X
- 2.4 SIRA 04 ATEX 1267X

Ambient temperature

- 3.1 -20 ... 55 °C (-4 ... 131 °F)
- 3.2 -40 ... 55 °C (-40 ... 131 °F)

IECEX approval

- 4.1 IECEX SIR 08.0055
- 4.2 IECEX SIR 08.0056X
- 4.3 IECEX SIR 08.0057X
- 4.4 IECEX SIR 08.0066X

GOST-R approval

- 5.1 GOST-R B00218
- 5.2 GOST-R B01008

Cross-references to product type please see overleaf

This datasheet does not constitute any contract obligation.

Pepperl+Fuchs reserves the right to modify the products herein illustrated without prior notice. Copyright Pepperl+Fuchs srl - Italy: +39 039 6292 1

SD/SF - Certification cross-reference

for certification characteristics please see table above

Type	Type of protection	Certification	Ambient temperature	IECEX	GOST-R
	see (1)	see (2)		see (4)	see (5)
SD204	1.6	2.1	-40 ... 55 °C (-40 ... 131 °F)	4.4	5.2
SFA204	1.1, 1.4	2.3	-40 ... 55 °C (-40 ... 131 °F)	4.2	5.1
SFI204	1.1, 1.4	2.3	-40 ... 55 °C (-40 ... 131 °F)	4.2	5.1
SFS204	1.1, 1.4	2.3	-40 ... 55 °C (-40 ... 131 °F)	4.2	5.1
SDA206	1.3, 1.5	2.2	-20 ... 55 °C (-4 ... 131 °F)	4.1	5.1
SDI206	1.3, 1.5	2.2	-20 ... 55 °C (-4 ... 131 °F)	4.1	5.1
SDSS206	1.3, 1.5	2.2	-40 ... 55 °C (-40 ... 131 °F)	4.1	5.1
SD254	1.6	2.1	-40 ... 55 °C (-40 ... 131 °F)	4.4	5.2
SDA256	1.3, 1.5	2.2	-20 ... 55 °C (-4 ... 131 °F)	4.1	5.1
SDI256	1.3, 1.5	2.2	-20 ... 55 °C (-4 ... 131 °F)	4.1	5.1
SDSS256	1.3, 1.5	2.2	-40 ... 55 °C (-40 ... 131 °F)	4.1	5.1
SD324	1.6	2.1	-40 ... 55 °C (-40 ... 131 °F)	4.4	5.2
SFA324	1.1, 1.4	2.3	-40 ... 55 °C (-40 ... 131 °F)	4.2	5.1
SFI324	1.1, 1.4	2.3	-40 ... 55 °C (-40 ... 131 °F)	4.2	5.1
SFS324	1.1, 1.4	2.3	-40 ... 55 °C (-40 ... 131 °F)	4.2	5.1
SDA326	1.3, 1.5	2.2	-20 ... 55 °C (-4 ... 131 °F)	4.1	5.1
SDI326	1.3, 1.5	2.2	-20 ... 55 °C (-4 ... 131 °F)	4.1	5.1
SDSS326	1.3, 1.5	2.2	-20 ... 55 °C (-4 ... 131 °F)	4.1	5.1
SD404	1.6	2.1	-40 ... 55 °C (-40 ... 131 °F)	4.4	5.2
SD634	1.6	2.1	-40 ... 55 °C (-40 ... 131 °F)	4.4	5.2
SFA634	1.1, 1.4	2.3	-40 ... 55 °C (-40 ... 131 °F)	4.2	5.1
SFI634	1.1, 1.4	2.3	-40 ... 55 °C (-40 ... 131 °F)	4.2	5.1
SFS634	1.1, 1.4	2.3	-40 ... 55 °C (-40 ... 131 °F)	4.2	5.1
SDA636	1.3, 1.5	2.2	-20 ... 55 °C (-4 ... 131 °F)	4.1	5.1
SDI636	1.3, 1.5	2.2	-20 ... 55 °C (-4 ... 131 °F)	4.1	5.1
SDSS636	1.3, 1.5	2.2	-20 ... 55 °C (-4 ... 131 °F)	4.1	5.1
SDA804	1.3	2.2	-20 ... 55 °C (-4 ... 131 °F)	4.1	5.2
SDI804	1.3	2.2	-20 ... 55 °C (-4 ... 131 °F)	4.1	5.2
SDSS804	1.3	2.2	-20 ... 55 °C (-4 ... 131 °F)	4.1	5.2
SDA806	1.1	2.3	-40 ... 55 °C (-40 ... 131 °F)	4.2	5.2
SDI806	1.1	2.3	-40 ... 55 °C (-40 ... 131 °F)	4.2	5.2
SDSS806	1.1	2.3	-40 ... 55 °C (-40 ... 131 °F)	4.2	5.2
SDA1004	1.3	2.2	-20 ... 55 °C (-4 ... 131 °F)	4.1	5.2
SDI1004	1.3	2.2	-40 ... 55 °C (-40 ... 131 °F)	4.1	5.2
SDSS1004	1.3	2.2	-20 ... 55 °C (-4 ... 131 °F)	4.1	5.2
SDA1006	1.1	2.3	-40 ... 55 °C (-40 ... 131 °F)	4.2	5.2
SDI1006	1.1	2.3	-40 ... 55 °C (-40 ... 131 °F)	4.2	5.2
SDSS1006	1.1	2.3	-40 ... 55 °C (-40 ... 131 °F)	4.2	5.2

Table continues overleaf

SD/SF - Certification cross-reference continued

for certification characteristics please see table above

Type	Type of protection	Certification	Ambient temperature	IECEX	GOST-R
	see (1)	see (2)		see (4)	see (5)
SDA1254	1.1	2.3	-40 ... 55 °C (-40 ... 131 °F)	4.2	5.2
SDI1254	1.1	2.3	-40 ... 55 °C (-40 ... 131 °F)	4.2	5.2
SDSS1254	1.1	2.3	-40 ... 55 °C (-40 ... 131 °F)	4.2	5.2
SFA1254	1.1, 1.4	2.3	-40 ... 55 °C (-40 ... 131 °F)	4.2	5.1
SFI1254	1.1, 1.4	2.3	-40 ... 55 °C (-40 ... 131 °F)	4.2	5.1
SFS1254	1.1, 1.4	2.3	-40 ... 55 °C (-40 ... 131 °F)	4.2	5.1
SDA1256	1.1	2.3	-40 ... 55 °C (-40 ... 131 °F)	4.2	5.2
SDI1256	1.1	2.3	-40 ... 55 °C (-40 ... 131 °F)	4.2	5.2
SDSS1256	1.1	2.3	-40 ... 55 °C (-40 ... 131 °F)	4.2	5.2
SDA1604	1.1	2.3	-40 ... 55 °C (-40 ... 131 °F)	4.2	5.2
SDI1604	1.1	2.3	-40 ... 55 °C (-40 ... 131 °F)	4.2	5.2
SDSS1604	1.1	2.3	-40 ... 55 °C (-40 ... 131 °F)	4.2	5.2
SDA1606	1.1	2.3	-40 ... 55 °C (-40 ... 131 °F)	4.2	5.2
SDI1606	1.1	2.3	-40 ... 55 °C (-40 ... 131 °F)	4.2	5.2
SDSS1606	1.1	2.3	-40 ... 55 °C (-40 ... 131 °F)	4.2	5.2
SDA2004	1.1	2.3	-40 ... 55 °C (-40 ... 131 °F)	4.2	5.2
SDI2004	1.1	2.3	-40 ... 55 °C (-40 ... 131 °F)	4.2	5.2
SDSS2004	1.1	2.3	-40 ... 55 °C (-40 ... 131 °F)	4.2	5.2
SDA2006	1.1	2.3	-40 ... 55 °C (-40 ... 131 °F)	4.2	5.2
SDI2006	1.1	2.3	-40 ... 55 °C (-40 ... 131 °F)	4.2	5.2
SDSS2006	1.1	2.3	-40 ... 55 °C (-40 ... 131 °F)	4.2	5.2
SDA2504	1.2	2.4	-40 ... 55 °C (-40 ... 131 °F)	4.3	5.2
SDI2504	1.2	2.4	-40 ... 55 °C (-40 ... 131 °F)	4.3	5.2
SDSS2504	1.2	2.4	-40 ... 55 °C (-40 ... 131 °F)	4.3	5.2
SDA2506	1.2	2.4	-40 ... 55 °C (-40 ... 131 °F)	4.3	5.2
SDI2506	1.2	2.4	-40 ... 55 °C (-40 ... 131 °F)	4.3	5.2
SDSS2506	1.2	2.4	-40 ... 55 °C (-40 ... 131 °F)	4.3	5.2
SDA3154	1.2	2.4	-40 ... 55 °C (-40 ... 131 °F)	4.3	5.2
SDI3154	1.2	2.4	-40 ... 55 °C (-40 ... 131 °F)	4.3	5.2
SDSS3154	1.2	2.4	-40 ... 55 °C (-40 ... 131 °F)	4.3	5.2
SDA3156	1.2	2.4	-40 ... 55 °C (-40 ... 131 °F)	4.3	5.2
SDI3156	1.2	2.4	-40 ... 55 °C (-40 ... 131 °F)	4.3	5.2
SDSS3156	1.2	2.4	-40 ... 55 °C (-40 ... 131 °F)	4.3	5.2

This datasheet does not constitute any contract obligation.

Pepperl+Fuchs reserves the right to modify the products herein illustrated without prior notice. Copyright Pepperl+Fuchs srl - Italy: +39 039 6292 1

SD/SF - Dimensions Data Table

Type	Current [A]	Poles qty.	Dimensions [mm]			Fixation [mm]			Enclosure material	Weight approx. [kg]	Drawing reference see *1*
			A	B	C	D	E	Diam. J			
SD204	20	4	168	125	146	190	78	7.25	cast iron	6.5	A
SFA204	20	4	335	310	248	360	240	10.2	cast aluminium	19	C
SFI204	20	4	335	310	248	360	240	10.2	cast iron	50	C
SFS204	20	4	335	310	248	360	240	10.2	cast stainless steel	52	C
SDA206	20	6	210	185	200	240	120	9.1	cast aluminium	8	B
SDI206	20	6	210	185	200	240	120	9.1	cast iron	20	B
SDSS206	20	6	210	185	200	240	120	9.1	cast stainless steel	21	B
SD254	25	4	168	125	146	190	78	7.25	cast iron	6.5	A
SDA256	25	6	210	185	200	240	120	9.1	cast aluminium	8	B
SDI256	25	6	210	185	200	240	120	9.1	cast iron	20	B
SDSS256	25	6	210	185	200	240	120	9.1	cast stainless steel	21	B
SD324	32	4	168	125	146	190	78	7.25	cast iron	6.5	A
SFA324	32	4	335	310	248	360	240	10.2	cast aluminium	19	C
SFI324	32	4	335	310	248	360	240	10.2	cast iron	50	C
SFS324	32	4	335	310	248	360	240	10.2	cast stainless steel	52	C
SDA326	32	6	210	185	200	240	120	9.1	cast aluminium	8	B
SDI326	32	6	210	185	200	240	120	9.1	cast iron	20	B
SDSS326	32	6	210	185	200	240	120	9.1	cast stainless steel	21	B
SD404	40	4	218	150	169	240	78	7.25	cast iron	11	A
SD634	63	4	218	150	169	240	78	7.25	cast iron	11	A
SFA634	63	4	335	310	248	360	240	10.2	cast aluminium	19	C
SFI634	63	4	335	310	248	360	240	10.2	cast iron	50	C
SFS634	63	4	335	310	248	360	240	10.2	cast stainless steel	52	C
SDA636	63	6	210	185	200	240	120	9.1	cast aluminium	8	B
SDI636	63	6	210	185	200	240	120	9.1	cast iron	20	B
SDSS636	63	6	210	185	200	240	120	9.1	cast stainless steel	21	B
SDA804	80	4	210	185	200	240	120	9.1	cast aluminium	8	B
SDI804	80	4	210	185	200	240	120	9.1	cast iron	20	B
SDSS804	80	4	210	185	200	240	120	9.1	cast stainless steel	21	B
SDA806	80	6	335	310	248	360	240	10.2	cast aluminium	19	C
SDI806	80	6	335	310	248	360	240	10.2	cast iron	50	C
SDSS806	80	6	335	310	248	360	240	10.2	cast stainless steel	52	C
SDA1004	100	4	210	185	200	240	120	9.1	cast aluminium	8	B
SDI1004	100	4	210	185	200	240	120	9.1	cast iron	20	B
SDSS1004	100	4	210	185	200	240	120	9.1	cast stainless steel	21	B
SDA1006	100	6	335	310	253	360	240	10.2	cast aluminium	19	C
SDI1006	100	6	335	310	253	360	240	10.2	cast iron	50	C
SDSS1006	100	6	335	310	253	360	240	10.2	cast stainless steel	52	C

Table continues overleaf

1 Reference drawings see at first page SD/SF

SD/SF - Dimensions Data Table continued

Type	Current [A]	Poles qty.	Dimensions [mm]			Fixation [mm]			Enclosure material	Weight approx. [kg]	Drawing reference see *1*
			A	B	C	D	E	Diam. J			
SDA1254	125	4	335	310	253	360	240	10.2	cast aluminium	19	C
SDI1254	125	4	335	310	253	360	240	10.2	cast iron	50	C
SDSS1254	125	4	335	310	253	360	240	10.2	cast stainless steel	52	C
SFA1254	125	4	335	310	248	360	240	10.2	cast aluminium	19	C
SFI1254	125	4	335	310	248	360	240	10.2	cast iron	50	C
SFS1254	125	4	335	310	248	360	240	10.2	cast stainless steel	52	C
SDA1256	125	6	335	310	253	360	240	10.2	cast aluminium	19	C
SDI1256	125	6	335	310	253	360	240	10.2	cast iron	50	C
SDSS1256	125	6	335	310	253	360	240	10.2	cast stainless steel	52	C
SDA1604	160	4	335	310	253	360	240	10.2	cast aluminium	19	C
SDI1604	160	4	335	310	253	360	240	10.2	cast iron	50	C
SDSS1604	160	4	335	310	253	360	240	10.2	cast stainless steel	52	C
SDA1606	160	6	335	310	253	360	240	10.2	cast aluminium	19	C
SDI1606	160	6	335	310	253	360	240	10.2	cast iron	50	C
SDSS1606	160	6	335	310	253	360	240	10.2	cast stainless steel	52	C
SDA2004	200	4	335	310	253	360	240	10.2	cast aluminium	19	C
SDI2004	200	4	335	310	253	360	240	10.2	cast iron	50	C
SDSS2004	200	4	335	310	253	360	240	10.2	cast stainless steel	52	C
SDA2006	200	6	335	310	253	360	240	10.2	cast aluminium	19	C
SDI2006	200	6	335	310	253	360	240	10.2	cast iron	50	C
SDSS2006	200	6	335	310	253	360	240	10.2	cast stainless steel	52	C
SDA2504	250	4	560	560	338	650	400	10.2	cast aluminium	72	D
SDI2504	250	4	560	560	338	650	400	10.2	cast iron	172	D
SDSS2504	250	4	560	560	338	650	400	10.2	cast stainless steel	184	D
SDA2506	250	6	560	560	338	650	400	10.2	cast aluminium	72	D
SDI2506	250	6	560	560	338	650	400	10.2	cast iron	172	D
SDSS2506	250	6	560	560	338	650	400	10.2	cast stainless steel	184	D
SDA3154	315	4	560	560	338	650	400	10.2	cast aluminium	72	D
SDI3154	315	4	560	560	338	650	400	10.2	cast iron	172	D
SDSS3154	315	4	560	560	338	650	400	10.2	cast stainless steel	184	D
SDA3156	315	6	560	560	338	650	400	10.2	cast aluminium	72	D
SDI3156	315	6	560	560	338	650	400	10.2	cast iron	172	D
SDSS3156	315	6	560	560	338	650	400	10.2	cast stainless steel	184	D

1 Reference drawings see at first page SD/SF

This datasheet does not constitute any contract obligation.

Pepperl+Fuchs reserves the right to modify the products herein illustrated without prior notice. Copyright Pepperl+Fuchs srl - Italy: +39 039 6292 1

SD/SF - Mechanical Specification

Type	Current	Poles	Cable entries		Cover fixing screws	Ingress protection	Seal	Enclosure material
	[A]	qty.	Face [A]	Face [B]	Stainless steel	EN60529	see *1*	
SD204	20	4	1 x M20	2 x M20	M6	IP65	1	cast iron
SFA204	20	4	-	3 x M20	M8	IP66	2	cast aluminium
SFI204	20	4	-	3 x M20	M8	IP66	2	cast iron
SFS204	20	4	-	3 x M20	M6	IP66	1	cast stainless steel
SDA206	20	6	1 x M20	2 x M20	M6	IP66	2	cast aluminium
SDI206	20	6	1 x M20	2 x M20	M6	IP66	2	cast iron
SDSS206	20	6	1 x M20	2 x M20	M6	IP66	2	cast stainless steel
SD254	25	4	1 x M20	2 x M20	M6	IP65	1	cast iron
SDA256	25	6	1 x M20	2 x M20	M6	IP66	1	cast aluminium
SDI256	25	6	1 x M20	2 x M20	M6	IP66	1	cast iron
SDSS256	25	6	1 x M20	2 x M20	M6	IP66	2	cast stainless steel
SD324	32	4	1 x M20	2 x M20	M6	IP65	1	cast iron
SFA324	32	4	-	3 x M20	M8	IP66	2	cast aluminium
SFI324	32	4	-	3 x M20	M8	IP66	2	cast iron
SFS324	32	4	-	3 x M20	M6	IP66	1	cast stainless steel
SDA326	32	6	1 x M25	2 x M25	M6	IP66	1	cast aluminium
SDI326	32	6	1 x M25	2 x M25	M6	IP66	1	cast iron
SDSS326	32	6	1 x M25	2 x M25	M6	IP66	2	cast stainless steel
SD404	40	4	1 x M20	2 x M20	M6	IP65	1	cast iron
SD634	63	4	1 x M25	2 x M25	M6	IP65	1	cast iron
SFA634	63	4	-	3 x M32	M8	IP66	2	cast aluminium
SFI634	63	4	-	3 x M32	M8	IP66	2	cast iron
SFS634	63	4	-	3 x M32	M6	IP66	1	cast stainless steel
SDA636	63	6	1 x M25	2 x M25	M6	IP66	2	cast aluminium
SDI636	63	6	1 x M25	2 x M25	M6	IP66	2	cast iron
SDSS636	63	6	1 x M25	2 x M25	M6	IP66	2	cast stainless steel
SDA804	80	4	1 x M25	2 x M25	M6	IP66	2	cast aluminium
SDI804	80	4	1 x M25	2 x M25	M6	IP66	2	cast iron
SDSS804	80	4	1 x M25	2 x M25	M6	IP66	2	cast stainless steel
SDA806	80	6	-	3 x M25	M8	IP66	2	cast aluminium
SDI806	80	6	-	3 x M25	M6	IP65	2	cast iron
SDSS806	80	6	-	3 x M25	M6	IP65	1	cast stainless steel
SDA1004	100	4	1 x M25	2 x M25	M6	IP66	2	cast aluminium
SDI1004	100	4	1 x M25	2 x M25	M6	IP66	2	cast iron
SDSS1004	100	4	1 x M25	2 x M25	M6	IP66	2	cast stainless steel
SDA1006	100	6	-	3 x M25	M8	IP66	2	cast aluminium
SDI1006	100	6	-	3 x M25	M6	IP66	2	cast iron
SDSS1006	100	6	-	3 x M25	M6	IP65	1	cast stainless steel

Table continues overleaf

SD/SF - Mechanical Specification continued

Type	Current [A]	Poles qty.	Cable entries		Cover fixing screws Stainless steel	Ingress protection EN60529	Seal see *1*	Enclosure material
			Face [A]	Face [B]				
SDA1254	125	4	-	1 x M20, 2 x M32	M8	IP66	2	cast aluminium
SDI1254	125	4	-	1 x M20, 2 x M32	M8	IP66	2	cast iron
SDSS1254	125	4	-	1 x M20, 2 x M32	M6	IP66	1	cast stainless steel
SFA1254	125	4	-	1 x M20, 2 x M40	M8	IP66	2	cast aluminium
SFI1254	125	4	-	1 x M20, 2 x M40	M8	IP66	2	cast iron
SFS1254	125	4	-	1 x M20, 2 x M40	M6	IP66	1	cast stainless steel
SDA1256	125	6	-	1 x M20, 2 x M32	M8	IP66	2	cast aluminium
SDI1256	125	6	-	1 x M20, 2 x M32	M8	IP66	2	cast iron
SDSS1256	125	6	-	1 x M20, 2 x M32	M6	IP66	1	cast stainless steel
SDA1604	160	4	-	1 x M20, 2 x M40	M8	IP66	2	cast aluminium
SDI1604	160	4	-	1 x M20, 2 x M40	M8	IP66	2	cast iron
SDSS1604	160	4	-	1 x M20, 2 x M40	M6	IP66	1	cast stainless steel
SDA1606	160	6	-	1 x M20, 2 x M40	M8	IP66	2	cast aluminium
SDI1606	160	6	-	1 x M20, 2 x M40	M8	IP66	2	cast iron
SDSS1606	160	6	-	1 x M20, 2 x M40	M6	IP66	1	cast stainless steel
SDA2004	200	4	-	1 x M20, 2 x M50	M8	IP66	2	cast aluminium
SDI2004	200	4	-	1 x M20, 2 x M50	M8	IP66	2	cast iron
SDSS2004	200	4	-	1 x M20, 2 x M50	M6	IP66	1	cast stainless steel
SDA2006	200	6	-	1 x M20, 2 x M50	M8	IP66	2	cast aluminium
SDI2006	200	6	-	1 x M20, 2 x M50	M8	IP66	2	cast iron
SDSS2006	200	6	-	1 x M20, 2 x M50	M6	IP66	1	cast stainless steel
SDA2504	250	4	-	1 x M20, 2 x M63	M10	IP66	2	cast aluminium
SDI2504	250	4	-	1 x M20, 2 x M63	M10	IP66	2	cast iron
SDSS2504	250	4	-	1 x M20, 2 x M63	M10	IP66	1	cast stainless steel
SDA2506	250	6	-	1 x M20, 2 x M63	M10	IP66	2	cast aluminium
SDI2506	250	6	-	1 x M20, 2 x M63	M10	IP66	2	cast iron
SDSS2506	250	6	-	1 x M20, 2 x M63	M10	IP66	1	cast stainless steel
SDA3154	315	4	-	1 x M20, 2 x M63	M10	IP66	2	cast aluminium
SDI3154	315	4	-	1 x M20, 2 x M63	M10	IP66	2	cast iron
SDSS3154	315	4	-	1 x M20, 2 x M63	M10	IP66	1	cast stainless steel
SDA3156	315	6	-	1 x M20, 2 x M63	M10	IP66	2	cast aluminium
SDI3156	315	6	-	1 x M20, 2 x M63	M10	IP66	2	cast iron
SDSS3156	315	6	-	1 x M20, 2 x M63	M10	IP66	1	cast stainless steel

1 Seal:

1 - Seal by grease

2 - One piece closed cell neoprene

This datasheet does not constitute any contract obligation.

Pepperl+Fuchs reserves the right to modify the products herein illustrated without prior notice. Copyright Pepperl+Fuchs srl - Italy: +39 039 6292 1





This datasheet does not constitute any contract obligation.

Pepperl+Fuchs reserves the right to modify the products herein illustrated without prior notice. Copyright Pepperl+Fuchs srl - Italy: +39 039 6292 1

Description:

The DOL range of motor starters and DOLSD range of motor starters with switch disconnectors are safely protected in flame-proof enclosures. They are suitable for Ex e motors. They are available with various contactor ratings and coil voltages.

Application:

The DOL and DOLSD ranges of motor starters are designed for safe operation of machinery and drives in gas or dust explosion hazardous areas.

Materials:

Body: Cast iron, aluminium and stainless steel.
Screws: Stainless steel.
For details see data tables overleaf.

Certification characteristics:

Marking to 94/9/EC: II 2GD
Zones: 1 – 21 – 2 – 22

For type of protection, certificates, ambient temperature ranges and ingress protection please see data tables overleaf.

Threads:

Metric threaded, for details see Mechanical Specification.

Inhibiting treatments:

Zinc rich epoxy powder primer plus epoxy powder top coat black.

Features:

Labeling: OFF – ON (DOLSD range only)
Operator lock: Padlockable in OFF position (DOLSD range only)
Enclosure cover: hinged non-detachable
Mounting: 2 x fabricated stainless steel mounting straps.

Enclosure types:

For drawing references, dimensions [mm] and approx. weight [kg] see Dimensions Data Table.

Drawing DOL

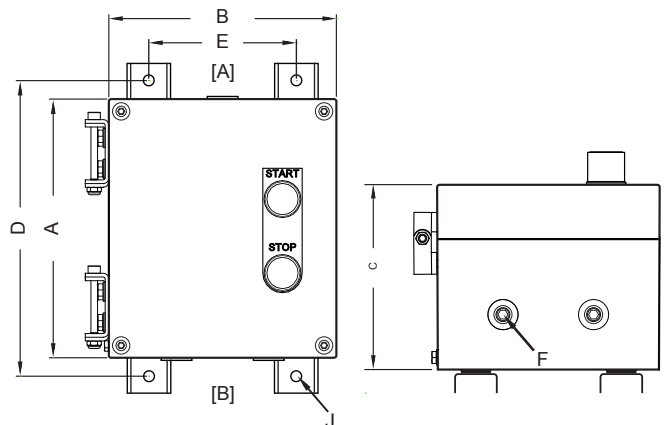

Legend:

- A - Maximum external dimension.
- B - Maximum external dimension.
- C - Maximum external dimension.
- D - Fixing holes wheel base.
- E - Fixing holes wheel base.
- F - Cable entry diameter.
- J - Fixing holes diameter.
- [A] - Entry face.
- [B] - Entry face.

For details see Dimensions Data Table.

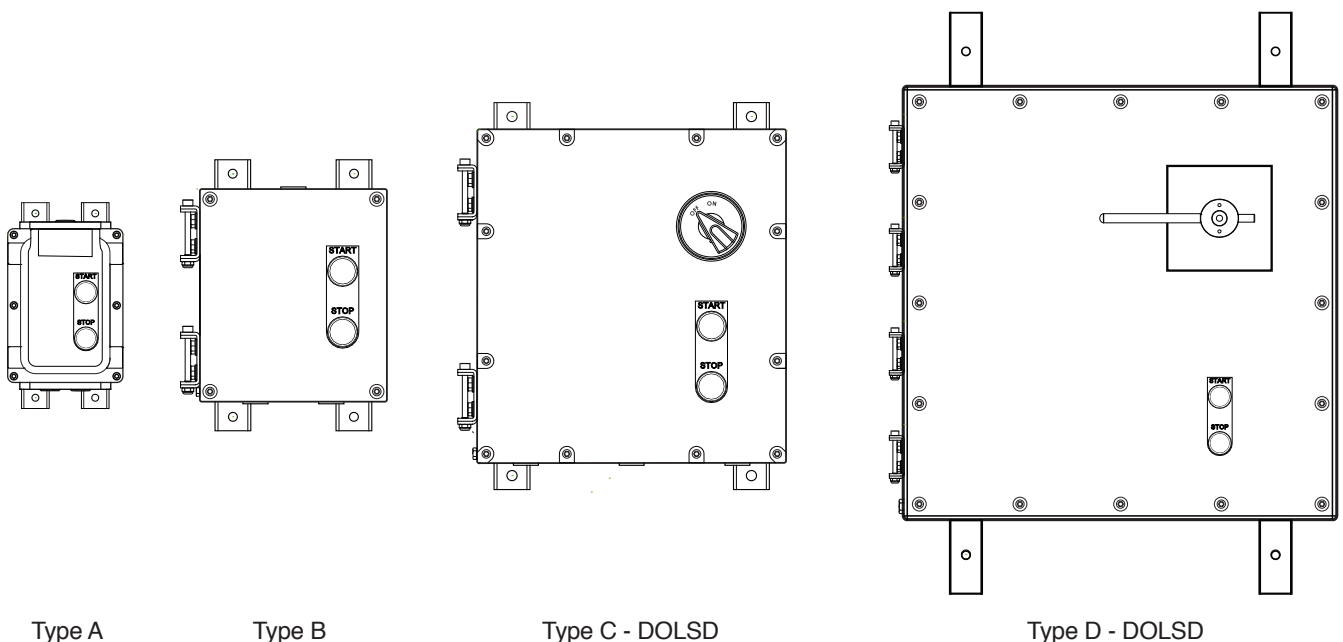

Release date 2013-03-20 - A0

DOL/DOLSD - Electrical Specification

Type	Power	Current AC3	Coil Voltage	Terminal capacity	Grounding	Overload relay	Poles *2*	Enclosure material
	[kW]	[A]	[V]	[mm ²]	see *1*		qty.	
DOL1.1/240	1.1	7	240	2x 1 ... 6, 2x 1 ... 4	-	4 ... 6 A	-	cast iron
DOL1.5/240	1.5	7	240	2x 1 ... 6, 2x 1 ... 4	-	6 ... 10 A	-	cast iron
DOL2.2/240	2.2	7	240	2x 1 ... 6, 2x 1 ... 4	-	6 ... 10 A	-	cast iron
DOL3/240	3	7	240	2x 1 ... 6, 2x 1 ... 4	-	6 ... 10 A	-	cast iron
DOL4/240	4	9	240	2x 1 ... 6, 2x 1 ... 4	-	6 ... 10 A	-	cast iron
DOL4/415	4	9	415	2x 1 ... 6, 2x 1 ... 4	-	6 ... 10 A	-	cast iron
DOL5.5/240	5.5	12	240	2x 1 ... 6, 2x 1 ... 4	-	9 ... 12 A	-	cast iron
DOL5.5/415	5.5	12	415	2x 1 ... 6, 2x 1 ... 4	-	9 ... 12 A	-	cast iron
DOL7.5/240	7.5	15	240	2x 1 ... 6, 2x 1 ... 4	-	12 ... 16 A	-	cast iron
DOL7.5/415	7.5	15	415	2x 1 ... 6, 2x 1 ... 4	-	12 ... 16 A	-	cast iron
DOL11/240/AL	11	25	240	7x 1.5 ... 16	1x	16 ... 24 A	-	cast aluminium
DOL11/240/CI	11	25	240	7x 1.5 ... 16	1x	16 ... 24 A	-	cast iron
DOL11/240/SS	11	25	240	7x 1.5 ... 16	1x	16 ... 24 A	-	cast stainless steel
DOL11/415/AL	11	25	415	7x 1.5 ... 16	1x	16 ... 24 A	-	cast aluminium
DOL11/415/CI	11	25	415	7x 1.5 ... 16	1x	16 ... 24 A	-	cast iron
DOL11/415/SS	11	25	415	7x 1.5 ... 16	1x	16 ... 24 A	-	cast stainless steel
DOL15/240/AL	15	32	240	7x 1.5 ... 16	1x	24 ... 32 A	-	cast aluminium
DOL15/240/CI	15	32	240	7x 1.5 ... 16	1x	24 ... 32 A	-	cast iron
DOL15/240/SS	15	32	240	7x 1.5 ... 16	1x	24 ... 32 A	-	cast stainless steel
DOL15/415/AL	15	32	415	7x 1.5 ... 16	1x	24 ... 32 A	-	cast aluminium
DOL15/415/CI	15	32	415	7x 1.5 ... 16	1x	24 ... 32 A	-	cast iron
DOL15/415/SS	15	32	415	7x 1.5 ... 16	1x	24 ... 32 A	-	cast stainless steel
DOL18.5/240/AL	18.5	40	240	8x 1.5 ... 16, 6x 0.5 ... 4	2x	24 ... 40 A	-	cast aluminium
DOL18.5/240/CI	18.5	40	240	8x 1.5 ... 16, 6x 0.5 ... 4	2x	24 ... 40 A	-	cast iron
DOL18.5/240/SS	18.5	40	240	8x 1.5 ... 16, 6x 0.5 ... 4	2x	24 ... 40 A	-	cast stainless steel
DOL18.5/415/AL	18.5	40	415	8x 1.5 ... 16, 6x 0.5 ... 4	2x	24 ... 40 A	-	cast aluminium
DOL18.5/415/CI	18.5	40	415	8x 1.5 ... 16, 6x 0.5 ... 4	2x	24 ... 40 A	-	cast iron
DOL18.5/415/SS	18.5	40	415	8x 1.5 ... 16, 6x 0.5 ... 4	2x	24 ... 40 A	-	cast stainless steel
DOL22/240/AL	22	50	240	8x 1.5 ... 16, 6x 0.5 ... 4	2x	40 ... 57 A	-	cast aluminium
DOL22/240/CI	22	50	240	8x 1.5 ... 16, 6x 0.5 ... 4	2x	40 ... 57 A	-	cast iron
DOL22/240/SS	22	50	240	8x 1.5 ... 16, 6x 0.5 ... 4	2x	40 ... 57 A	-	cast stainless steel
DOL22/415/AL	22	50	415	8x 1.5 ... 16, 6x 0.5 ... 4	2x	40 ... 57 A	-	cast aluminium
DOL22/415/CI	22	50	415	8x 1.5 ... 16, 6x 0.5 ... 4	2x	40 ... 57 A	-	cast iron
DOL22/415/SS	22	50	415	8x 1.5 ... 16, 6x 0.5 ... 4	2x	40 ... 57 A	-	cast stainless steel
DOLSD22/240/AL	22	50	240	8x 1.5 ... 16, 6x 0.5 ... 4	2x	40 ... 57 A	4	cast aluminium
DOLSD22/240/CI	22	50	240	8x 1.5 ... 16, 6x 0.5 ... 4	2x	40 ... 57 A	4	cast iron
DOLSD22/240/SS	22	50	240	8x 1.5 ... 16, 6x 0.5 ... 4	2x	40 ... 57 A	4	cast stainless steel
DOLSD22/415/AL	22	50	415	8x 1.5 ... 16, 6x 0.5 ... 4	2x	40 ... 57 A	4	cast aluminium
DOLSD22/415/CI	22	50	415	8x 1.5 ... 16, 6x 0.5 ... 4	2x	40 ... 57 A	4	cast iron
DOLSD22/415/SS	22	50	415	8x 1.5 ... 16, 6x 0.5 ... 4	2x	40 ... 57 A	4	cast stainless steel

Table continues overleaf

Release date 2013-03-20 - AO

This datasheet does not constitute any contract obligation.

Pepperl+Fuchs reserves the right to modify the products herein illustrated without prior notice. Copyright Pepperl+Fuchs srl - Italy: +39 039 6292 1

DOL/DOLSD - Electrical Specification continued

Type	Power	Current AC3	Coil Voltage	Terminal capacity	Grounding	Overload relay	Poles *2*	Enclosure material
	[kW]	[A]	[V]	[mm ²]	see *1*		qty.	
DOL30/240/AL	30	65	240	8x 1.5 ... 16, 6x 0.5 ... 4	2x	40...57 A	-	cast aluminium
DOL30/240/CI	30	65	240	8x 1.5 ... 16, 6x 0.5 ... 4	2x	40...57 A	-	cast iron
DOL30/240/SS	30	65	240	8x 1.5 ... 16, 6x 0.5 ... 4	2x	40...57 A	-	cast stainless steel
DOL30/415/AL	30	65	415	8x 1.5 ... 16, 6x 0.5 ... 4	2x	40...57 A	-	cast aluminium
DOL30/415/CI	30	65	415	8x 1.5 ... 16, 6x 0.5 ... 4	2x	40...57 A	-	cast iron
DOL30/415/SS	30	65	415	8x 1.5 ... 16, 6x 0.5 ... 4	2x	40...57 A	-	cast stainless steel
DOLSD30/240/AL	30	65	240	8x 1.5 ... 16, 6x 0.5 ... 4	2x	40...57 A	4	cast aluminium
DOLSD30/240/CI	30	65	240	8x 1.5 ... 16, 6x 0.5 ... 4	2x	40...57 A	4	cast iron
DOLSD30/240/SS	30	65	240	8x 1.5 ... 16, 6x 0.5 ... 4	2x	40...57 A	4	cast stainless steel
DOLSD30/415/AL	30	65	415	8x 1.5 ... 16, 6x 0.5 ... 4	2x	40...57 A	4	cast aluminium
DOLSD30/415/CI	30	65	415	8x 1.5 ... 16, 6x 0.5 ... 4	2x	40...57 A	4	cast iron
DOLSD30/415/SS	30	65	415	8x 1.5 ... 16, 6x 0.5 ... 4	2x	40...57 A	4	cast stainless steel
DOL55/240/AL	55	115	240	8x 10 ... 50, 6x 0.5 ... 4	2x	95...125 A	-	cast aluminium
DOL55/240/CI	55	115	240	8x 10 ... 50, 6x 0.5 ... 4	2x	95...125 A	-	cast iron
DOL55/240/SS	55	115	240	8x 10 ... 50, 6x 0.5 ... 4	2x	95...125 A	-	cast stainless steel
DOL55/415/AL	55	115	415	8x 10 ... 50, 6x 0.5 ... 4	2x	95...125 A	-	cast aluminium
DOL55/415/CI	55	115	415	8x 10 ... 50, 6x 0.5 ... 4	2x	95...125 A	-	cast iron
DOL55/415/SS	55	115	415	8x 10 ... 50, 6x 0.5 ... 4	2x	95...125 A	-	cast stainless steel
DOLSD55/240/AL	55	115	240	8x 10 ... 50, 6x 0.5 ... 4	2x	95...125 A	4	cast aluminium
DOLSD55/240/CI	55	115	240	8x 10 ... 50, 6x 0.5 ... 4	2x	95...125 A	4	cast iron
DOLSD55/240/SS	55	115	240	8x 10 ... 50, 6x 0.5 ... 4	2x	95...125 A	4	cast stainless steel
DOLSD55/415/AL	55	115	415	8x 10 ... 50, 6x 0.5 ... 4	2x	95...125 A	4	cast aluminium
DOLSD55/415/CI	55	115	415	8x 10 ... 50, 6x 0.5 ... 4	2x	95...125 A	4	cast iron
DOLSD55/415/SS	55	115	415	8x 10 ... 50, 6x 0.5 ... 4	2x	95...125 A	4	cast stainless steel
DOL75/240/AL	75	150	240	8x 10 ... 70, 6x 0.5 ... 4	2x	120...142 A	-	cast aluminium
DOL75/240/CI	75	150	240	8x 10 ... 70, 6x 0.5 ... 4	2x	120...142 A	-	cast iron
DOL75/240/SS	75	150	240	8x 10 ... 70, 6x 0.5 ... 4	2x	120...142 A	-	cast stainless steel
DOL75/415/AL	75	150	415	8x 10 ... 70, 6x 0.5 ... 4	2x	120...142 A	-	cast aluminium
DOL75/415/CI	75	150	415	8x 10 ... 70, 6x 0.5 ... 4	2x	120...142 A	-	cast iron
DOL75/415/SS	75	150	415	8x 10 ... 70, 6x 0.5 ... 4	2x	120...142 A	-	cast stainless steel
DOLSD75/240/AL	75	150	240	8x 10 ... 70, 6x 0.5 ... 4	2x	120...142 A	4	cast aluminium
DOLSD75/240/CI	75	150	240	8x 10 ... 70, 6x 0.5 ... 4	2x	120...142 A	4	cast iron
DOLSD75/240/SS	75	150	240	8x 10 ... 70, 6x 0.5 ... 4	2x	120...142 A	4	cast stainless steel
DOLSD75/415/AL	75	150	415	8x 10 ... 70, 6x 0.5 ... 4	2x	120...142 A	4	cast aluminium
DOLSD75/415/CI	75	150	415	8x 10 ... 70, 6x 0.5 ... 4	2x	120...142 A	4	cast iron
DOLSD75/415/SS	75	150	415	8x 10 ... 70, 6x 0.5 ... 4	2x	120...142 A	4	cast stainless steel

Phases: 3

Grounding: Internal & external brass grounding terminals on base and lid

1 number of Ground Terminals

2 Switch Disconnectors only: Auxiliary contacts: 2 x n/o early break
 Labelling: OFF – ON
 Operator Lock: Padlockable in OFF position

Release date 2013-03-20 - A0

DOL/DOLSD - Certification characteristics

Marking to 94/9/EC

II 2 GD

Type of protection

- 1.1 Ex d IIB T5 Gb, Ex tb IIIC T82°C Db (ta ... +55°C)
- 1.2 Ex d IIB T5 Gb, Ex tb IIIC T87°C Db
- 1.3 Ex d IIB T5 Gb, Ex tb IIIC T95°C (ta ... +55°C)
- 1.4 Ex d IIB T6 Gb, Ex tb IIIC T85°C Db

Certificate

- 2.1 SIRA 02 ATEX 1332
- 2.2 SIRA 03 ATEX 1215
- 2.3 SIRA 04 ATEX 1266X
- 2.4 SIRA 04 ATEX 1267X

Ambient temperature

- 3.1 -20 ... 55 °C (-4 ... 131 °F)
- 3.2 -40 ... 55 °C (-40 ... 131 °F)

IECEX approval

- 4.1 IECEX SIR 08.0056X
- 4.2 IECEX SIR 08.0057X
- 4.3 IECEX SIR 08.0066X
- 4.4 IECEX SIR 08.0055

GOST-R approval

- 5.1 GOST-R B01008

Cross-references to product type please see table below

DOL/DOLSD - Certification cross-reference

for certification characteristics please see table above

Type	Type of protection	Ambient temperature	Certificate	IECEX	GOST-R
			see (2)	(4)	(5)
DOL1.1/240	Ex d IIB T6 Gb, Ex tb IIIC T85 °C Db	-40 ... 55 °C (-40 ... 131 °F)	2.1	4.3	5.1
DOL1.5/240	Ex d IIB T6 Gb, Ex tb IIIC T85 °C Db	-40 ... 55 °C (-40 ... 131 °F)	2.1	4.3	5.1
DOL2.2/240	Ex d IIB T6 Gb, Ex tb IIIC T85 °C Db	-40 ... 55 °C (-40 ... 131 °F)	2.1	4.3	5.1
DOL3/240	Ex d IIB T6 Gb, Ex tb IIIC T85 °C Db	-40 ... 55 °C (-40 ... 131 °F)	2.1	4.3	5.1
DOL4/240	Ex d IIB T6 Gb, Ex tb IIIC T85 °C Db	-40 ... 55 °C (-40 ... 131 °F)	2.1	4.3	5.1
DOL4/415	Ex d IIB T6 Gb, Ex tb IIIC T85 °C Db	-40 ... 55 °C (-40 ... 131 °F)	2.1	4.3	5.1
DOL5.5/240	Ex d IIB T6 Gb, Ex tb IIIC T85 °C Db	-40 ... 55 °C (-40 ... 131 °F)	2.1	4.3	5.1
DOL5.5/415	Ex d IIB T6 Gb, Ex tb IIIC T85 °C Db	-40 ... 55 °C (-40 ... 131 °F)	2.1	4.3	5.1
DOL7.5/240	Ex d IIB T6 Gb, Ex tb IIIC T85 °C Db	-40 ... 55 °C (-40 ... 131 °F)	2.1	4.3	5.1
DOL7.5/415	Ex d IIB T6 Gb, Ex tb IIIC T85 °C Db	-40 ... 55 °C (-40 ... 131 °F)	2.1	4.3	5.1
DOL11/240/AL	Ex d IIB T5 Gb, Ex tb IIIC T95 °C (ta ... +55 °C)	-20 ... 55 °C (-4 ... 131 °F)	2.2	4.4	5.1
DOL11/240/CI	Ex d IIB T5 Gb, Ex tb IIIC T95 °C (ta ... +55 °C)	-20 ... 55 °C (-4 ... 131 °F)	2.2	4.4	5.1
DOL11/240/SS	Ex d IIB T5 Gb, Ex tb IIIC T95 °C (ta ... +55 °C)	-20 ... 55 °C (-4 ... 131 °F)	2.2	4.4	5.1
DOL11/415/AL	Ex d IIB T5 Gb, Ex tb IIIC T95 °C (ta ... +55 °C)	-20 ... 55 °C (-4 ... 131 °F)	2.2	4.4	5.1
DOL11/415/CI	Ex d IIB T5 Gb, Ex tb IIIC T95 °C (ta ... +55 °C)	-20 ... 55 °C (-4 ... 131 °F)	2.2	4.4	5.1
DOL11/415/SS	Ex d IIB T5 Gb, Ex tb IIIC T95 °C (ta ... +55 °C)	-20 ... 55 °C (-4 ... 131 °F)	2.2	4.4	5.1
DOL15/240/AL	Ex d IIB T5 Gb, Ex tb IIIC T82 °C Db (ta ... +55 °C)	-20 ... 55 °C (-4 ... 131 °F)	2.2	4.4	5.1
DOL15/240/CI	Ex d IIB T5 Gb, Ex tb IIIC T82 °C Db (ta ... +55 °C)	-20 ... 55 °C (-4 ... 131 °F)	2.2	4.4	5.1
DOL15/240/SS	Ex d IIB T5 Gb, Ex tb IIIC T82 °C Db (ta ... +55 °C)	-20 ... 55 °C (-4 ... 131 °F)	2.2	4.4	5.1
DOL15/415/AL	Ex d IIB T5 Gb, Ex tb IIIC T82 °C Db (ta ... +55 °C)	-20 ... 55 °C (-4 ... 131 °F)	2.2	4.4	5.1
DOL15/415/CI	Ex d IIB T5 Gb, Ex tb IIIC T82 °C Db (ta ... +55 °C)	-20 ... 55 °C (-4 ... 131 °F)	2.2	4.4	5.1
DOL15/415/SS	Ex d IIB T5 Gb, Ex tb IIIC T82 °C Db (ta ... +55 °C)	-20 ... 55 °C (-4 ... 131 °F)	2.2	4.4	5.1

Table continues overleaf

Release date 2013-03-20 - AO

This datasheet does not constitute any contract obligation.

Pepperl+Fuchs reserves the right to modify the products herein illustrated without prior notice. Copyright Pepperl+Fuchs srl - Italy: +39 039 6292 1

DOL/DOLSD - Certification cross-reference continued

for certification characteristics please see table above

Type	Type of protection	Ambient temperature	Certificate	IECEX	GOST-R
			see (2)	(4)	(5)
DOL18.5/240/AL	Ex d IIB T5 Gb, Ex tb IIIC T82 °C Db (ta ... +55 °C)	-40 ... 55 °C (-40 ... 131 °F)	2.3	4.1	5.1
DOL18.5/240/CI	Ex d IIB T5 Gb, Ex tb IIIC T82 °C Db (ta ... +55 °C)	-40 ... 55 °C (-40 ... 131 °F)	2.3	4.1	5.1
DOL18.5/240/SS	Ex d IIB T5 Gb, Ex tb IIIC T82 °C Db (ta ... +55 °C)	-40 ... 55 °C (-40 ... 131 °F)	2.3	4.1	5.1
DOL18.5/415/AL	Ex d IIB T5 Gb, Ex tb IIIC T82 °C Db (ta ... +55 °C)	-40 ... 55 °C (-40 ... 131 °F)	2.3	4.1	5.1
DOL18.5/415/CI	Ex d IIB T5 Gb, Ex tb IIIC T82 °C Db (ta ... +55 °C)	-40 ... 55 °C (-40 ... 131 °F)	2.3	4.1	5.1
DOL18.5/415/SS	Ex d IIB T5 Gb, Ex tb IIIC T82 °C Db (ta ... +55 °C)	-40 ... 55 °C (-40 ... 131 °F)	2.3	4.1	5.1
DOL22/240/AL	Ex d IIB T5 Gb, Ex tb IIIC T82 °C Db (ta ... +55 °C)	-40 ... 55 °C (-40 ... 131 °F)	2.3	4.1	5.1
DOL22/240/CI	Ex d IIB T5 Gb, Ex tb IIIC T82 °C Db (ta ... +55 °C)	-40 ... 55 °C (-40 ... 131 °F)	2.3	4.1	5.1
DOL22/240/SS	Ex d IIB T5 Gb, Ex tb IIIC T82 °C Db (ta ... +55 °C)	-40 ... 55 °C (-40 ... 131 °F)	2.3	4.1	5.1
DOL22/415/AL	Ex d IIB T5 Gb, Ex tb IIIC T82 °C Db (ta ... +55 °C)	-40 ... 55 °C (-40 ... 131 °F)	2.3	4.1	5.1
DOL22/415/CI	Ex d IIB T5 Gb, Ex tb IIIC T82 °C Db (ta ... +55 °C)	-40 ... 55 °C (-40 ... 131 °F)	2.3	4.1	5.1
DOL22/415/SS	Ex d IIB T5 Gb, Ex tb IIIC T82 °C Db (ta ... +55 °C)	-40 ... 55 °C (-40 ... 131 °F)	2.3	4.1	5.1
DOLSD22/240/AL	Ex d IIB T5 Gb, Ex tb IIIC T82 °C Db (ta ... +55 °C)	-40 ... 55 °C (-40 ... 131 °F)	2.3	4.1	5.1
DOLSD22/240/CI	Ex d IIB T5 Gb, Ex tb IIIC T82 °C Db (ta ... +55 °C)	-40 ... 55 °C (-40 ... 131 °F)	2.3	4.1	5.1
DOLSD22/240/SS	Ex d IIB T5 Gb, Ex tb IIIC T82 °C Db (ta ... +55 °C)	-40 ... 55 °C (-40 ... 131 °F)	2.3	4.1	5.1
DOLSD22/415/AL	Ex d IIB T5 Gb, Ex tb IIIC T82 °C Db (ta ... +55 °C)	-40 ... 55 °C (-40 ... 131 °F)	2.3	4.1	5.1
DOLSD22/415/CI	Ex d IIB T5 Gb, Ex tb IIIC T82 °C Db (ta ... +55 °C)	-40 ... 55 °C (-40 ... 131 °F)	2.3	4.1	5.1
DOLSD22/415/SS	Ex d IIB T5 Gb, Ex tb IIIC T82 °C Db (ta ... +55 °C)	-40 ... 55 °C (-40 ... 131 °F)	2.3	4.1	5.1
DOL30/240/AL	Ex d IIB T5 Gb, Ex tb IIIC T82 °C Db (ta ... +55 °C)	-40 ... 55 °C (-40 ... 131 °F)	2.3	4.1	5.1
DOL30/240/CI	Ex d IIB T5 Gb, Ex tb IIIC T82 °C Db (ta ... +55 °C)	-40 ... 55 °C (-40 ... 131 °F)	2.3	4.1	5.1
DOL30/240/SS	Ex d IIB T5 Gb, Ex tb IIIC T82 °C Db (ta ... +55 °C)	-40 ... 55 °C (-40 ... 131 °F)	2.3	4.1	5.1
DOL30/415/AL	Ex d IIB T5 Gb, Ex tb IIIC T82 °C Db (ta ... +55 °C)	-40 ... 55 °C (-40 ... 131 °F)	2.3	4.1	5.1
DOL30/415/CI	Ex d IIB T5 Gb, Ex tb IIIC T82 °C Db (ta ... +55 °C)	-40 ... 55 °C (-40 ... 131 °F)	2.3	4.1	5.1
DOL30/415/SS	Ex d IIB T5 Gb, Ex tb IIIC T82 °C Db (ta ... +55 °C)	-40 ... 55 °C (-40 ... 131 °F)	2.3	4.1	5.1
DOLSD30/240/AL	Ex d IIB T5 Gb, Ex tb IIIC T82 °C Db (ta ... +55 °C)	-40 ... 55 °C (-40 ... 131 °F)	2.3	4.3	5.1
DOLSD30/240/CI	Ex d IIB T5 Gb, Ex tb IIIC T82 °C Db (ta ... +55 °C)	-40 ... 55 °C (-40 ... 131 °F)	2.3	4.3	5.1
DOLSD30/240/SS	Ex d IIB T5 Gb, Ex tb IIIC T82 °C Db (ta ... +55 °C)	-40 ... 55 °C (-40 ... 131 °F)	2.3	4.3	5.1
DOLSD30/415/AL	Ex d IIB T5 Gb, Ex tb IIIC T82 °C Db (ta ... +55 °C)	-40 ... 55 °C (-40 ... 131 °F)	2.3	4.3	5.1
DOLSD30/415/CI	Ex d IIB T5 Gb, Ex tb IIIC T82 °C Db (ta ... +55 °C)	-40 ... 55 °C (-40 ... 131 °F)	2.3	4.3	5.1
DOLSD30/415/SS	Ex d IIB T5 Gb, Ex tb IIIC T82 °C Db (ta ... +55 °C)	-40 ... 55 °C (-40 ... 131 °F)	2.3	4.3	5.1
DOL55/240/AL	Ex d IIB T5 Gb, Ex tb IIIC T87 °C Db	-40 ... 55 °C (-40 ... 131 °F)	2.4	4.2	5.1
DOL55/240/CI	Ex d IIB T5 Gb, Ex tb IIIC T87 °C Db	-40 ... 55 °C (-40 ... 131 °F)	2.4	4.2	5.1
DOL55/240/SS	Ex d IIB T5 Gb, Ex tb IIIC T87 °C Db	-40 ... 55 °C (-40 ... 131 °F)	2.4	4.2	5.1
DOL55/415/AL	Ex d IIB T5 Gb, Ex tb IIIC T87 °C Db	-40 ... 55 °C (-40 ... 131 °F)	2.4	4.2	5.1
DOL55/415/CI	Ex d IIB T5 Gb, Ex tb IIIC T87 °C Db	-40 ... 55 °C (-40 ... 131 °F)	2.4	4.2	5.1
DOL55/415/SS	Ex d IIB T5 Gb, Ex tb IIIC T87 °C Db	-40 ... 55 °C (-40 ... 131 °F)	2.4	4.2	5.1
DOLSD55/240/AL	Ex d IIB T5 Gb, Ex tb IIIC T87 °C Db	-40 ... 55 °C (-40 ... 131 °F)	2.4	4.2	5.1
DOLSD55/240/CI	Ex d IIB T5 Gb, Ex tb IIIC T87 °C Db	-40 ... 55 °C (-40 ... 131 °F)	2.4	4.2	5.1
DOLSD55/240/SS	Ex d IIB T5 Gb, Ex tb IIIC T87 °C Db	-40 ... 55 °C (-40 ... 131 °F)	2.4	4.2	5.1
DOLSD55/415/AL	Ex d IIB T5 Gb, Ex tb IIIC T87 °C Db	-40 ... 55 °C (-40 ... 131 °F)	2.4	4.2	5.1
DOLSD55/415/CI	Ex d IIB T5 Gb, Ex tb IIIC T87 °C Db	-40 ... 55 °C (-40 ... 131 °F)	2.4	4.2	5.1
DOLSD55/415/SS	Ex d IIB T5 Gb, Ex tb IIIC T87 °C Db	-40 ... 55 °C (-40 ... 131 °F)	2.4	4.2	5.1
DOL75/240/AL	Ex d IIB T5 Gb, Ex tb IIIC T87 °C Db	-40 ... 55 °C (-40 ... 131 °F)	2.4	4.2	5.1
DOL75/240/CI	Ex d IIB T5 Gb, Ex tb IIIC T87 °C Db	-40 ... 55 °C (-40 ... 131 °F)	2.4	4.2	5.1
DOL75/240/SS	Ex d IIB T5 Gb, Ex tb IIIC T87 °C Db	-40 ... 55 °C (-40 ... 131 °F)	2.4	4.2	5.1
DOL75/415/AL	Ex d IIB T5 Gb, Ex tb IIIC T87 °C Db	-40 ... 55 °C (-40 ... 131 °F)	2.4	4.2	5.1
DOL75/415/CI	Ex d IIB T5 Gb, Ex tb IIIC T87 °C Db	-40 ... 55 °C (-40 ... 131 °F)	2.4	4.2	5.1
DOL75/415/SS	Ex d IIB T5 Gb, Ex tb IIIC T87 °C Db	-40 ... 55 °C (-40 ... 131 °F)	2.4	4.2	5.1
DOLSD75/240/AL	Ex d IIB T5 Gb, Ex tb IIIC T87 °C Db	-40 ... 55 °C (-40 ... 131 °F)	2.4	4.2	5.1
DOLSD75/240/CI	Ex d IIB T5 Gb, Ex tb IIIC T87 °C Db	-40 ... 55 °C (-40 ... 131 °F)	2.4	4.2	5.1
DOLSD75/240/SS	Ex d IIB T5 Gb, Ex tb IIIC T87 °C Db	-40 ... 55 °C (-40 ... 131 °F)	2.4	4.2	5.1
DOLSD75/415/AL	Ex d IIB T5 Gb, Ex tb IIIC T87 °C Db	-40 ... 55 °C (-40 ... 131 °F)	2.4	4.2	5.1
DOLSD75/415/CI	Ex d IIB T5 Gb, Ex tb IIIC T87 °C Db	-40 ... 55 °C (-40 ... 131 °F)	2.4	4.2	5.1
DOLSD75/415/SS	Ex d IIB T5 Gb, Ex tb IIIC T87 °C Db	-40 ... 55 °C (-40 ... 131 °F)	2.4	4.2	5.1

Release date 2013-03-20 - AO

This datasheet does not constitute any contract obligation.

Pepperl+Fuchs reserves the right to modify the products herein illustrated without prior notice. Copyright Pepperl+Fuchs srl - Italy: +39 039 6292 1

Pepperl+Fuchs Group
www.pepperl-fuchs.com

USA: +1 330 486 0002
pa-info@us.pepperl-fuchs.com

Germany: +49 621 776 2222
pa-info@de.pepperl-fuchs.com

Singapore: +65 6779 9091
pa-info@sg.pepperl-fuchs.com

DOL/DOLSD - Dimensions Data Table

Type	Power [kW]	Dimensions [mm]			Fixation [mm]			Enclosure material	Weight approx. [kg]	Drawing reference see *1*
		A	B	C	D	E	Diam. J			
DOL1.1/240	1.1	218	150	104	240	78	7.25	cast iron	11	A
DOL1.5/240	1.5	218	150	104	240	78	7.25	cast iron	11	A
DOL2.2/240	2.2	218	150	104	240	78	7.25	cast iron	11	A
DOL3/240	3	218	150	104	240	78	7.25	cast iron	11	A
DOL4/240	4	218	150	104	240	78	7.25	cast iron	11	A
DOL4/415	4	218	150	104	240	78	7.25	cast iron	11	A
DOL5.5/240	5.5	218	150	104	240	78	7.25	cast iron	11	A
DOL5.5/415	5.5	218	150	104	240	78	7.25	cast iron	11	A
DOL7.5/240	7.5	218	150	104	240	78	7.25	cast iron	11	A
DOL7.5/415	7.5	218	150	104	240	78	7.25	cast iron	11	A
DOL11/240/AL	11	210	185	156	240	120	9.1	cast aluminium	8	B
DOL11/240/CI	11	210	185	156	240	120	9.1	cast iron	20	B
DOL11/240/SS	11	210	185	156	240	120	9.1	cast stainless steel	21	B
DOL11/415/AL	11	210	185	156	240	120	9.1	cast aluminium	8	B
DOL11/415/CI	11	210	185	156	240	120	9.1	cast iron	20	B
DOL11/415/SS	11	210	185	156	240	120	9.1	cast stainless steel	21	B
DOL15/240/AL	15	210	185	156	240	120	9.1	cast aluminium	8	B
DOL15/240/CI	15	210	185	156	240	120	9.1	cast iron	20	B
DOL15/240/SS	15	210	185	156	240	120	9.1	cast stainless steel	21	B
DOL15/415/AL	15	210	185	156	240	120	9.1	cast aluminium	8	B
DOL15/415/CI	15	210	185	156	240	120	9.1	cast iron	20	B
DOL15/415/SS	15	210	185	156	240	120	9.1	cast stainless steel	21	B
DOL18.5/240/AL	18.5	335	310	205	360	240	10.2	cast aluminium	19	C
DOL18.5/240/CI	18.5	335	310	205	360	240	10.2	cast iron	50	C
DOL18.5/240/SS	18.5	335	310	205	360	240	10.2	cast stainless steel	52	C
DOL18.5/415/AL	18.5	335	310	205	360	240	10.2	cast aluminium	19	C
DOL18.5/415/CI	18.5	335	310	205	360	240	10.2	cast iron	50	C
DOL18.5/415/SS	18.5	335	310	205	360	240	10.2	cast stainless steel	52	C
DOL22/240/AL	22	335	310	205	360	240	10.2	cast aluminium	19	C
DOL22/240/CI	22	335	310	205	360	240	10.2	cast iron	50	C
DOL22/240/SS	22	335	310	205	360	240	10.2	cast stainless steel	52	C
DOL22/415/AL	22	335	310	205	360	240	10.2	cast aluminium	19	C
DOL22/415/CI	22	335	310	205	360	240	10.2	cast iron	50	C
DOL22/415/SS	22	335	310	205	360	240	10.2	cast stainless steel	52	C
DOLSD22/240/AL	22	335	310	205	360	240	10.2	cast aluminium	19	C
DOLSD22/240/CI	22	335	310	205	360	240	10.2	cast iron	50	C
DOLSD22/240/SS	22	335	310	205	360	240	10.2	cast stainless steel	52	C
DOLSD22/415/AL	22	335	310	205	360	240	10.2	cast aluminium	19	C
DOLSD22/415/CI	22	335	310	205	360	240	10.2	cast iron	50	C
DOLSD22/415/SS	22	335	310	205	360	240	10.2	cast stainless steel	52	C

Table continues overleaf, *1* reference drawings see at first page DOL / DOLSD

Release date 2013-03-20 - AO

This datasheet does not constitute any contract obligation.

Pepperl+Fuchs reserves the right to modify the products herein illustrated without prior notice. Copyright Pepperl+Fuchs srl - Italy: +39 039 6292 1

DOL/DOLSD - Dimensions Data Table continued

Type	Power [kW]	Dimensions [mm]			Fixation [mm]			Enclosure material	Weight approx. [kg]	Drawing reference see *1*
		A	B	C	D	E	Diam. J			
DOL30/240/AL	30	335	310	205	360	240	10.2	cast aluminium	19	C
DOL30/240/CI	30	335	310	205	360	240	10.2	cast iron	50	C
DOL30/240/SS	30	335	310	205	360	240	10.2	cast stainless steel	52	C
DOL30/415/AL	30	335	310	205	360	240	10.2	cast aluminium	19	C
DOL30/415/CI	30	335	310	205	360	240	10.2	cast iron	50	C
DOL30/415/SS	30	335	310	205	360	240	10.2	cast stainless steel	52	C
DOLSD30/240/AL	30	335	310	205	360	240	10.2	cast aluminium	19	C
DOLSD30/240/CI	30	335	310	205	360	240	10.2	cast iron	50	C
DOLSD30/240/SS	30	335	310	205	360	240	10.2	cast stainless steel	52	C
DOLSD30/415/AL	30	335	310	205	360	240	10.2	cast aluminium	19	C
DOLSD30/415/CI	30	335	310	205	360	240	10.2	cast iron	50	C
DOLSD30/415/SS	30	335	310	205	360	240	10.2	cast stainless steel	52	C
DOL55/240/AL	55	560	560	266	650	400	10.2	cast aluminium	72	D
DOL55/240/CI	55	560	560	266	650	400	10.2	cast iron	172	D
DOL55/240/SS	55	560	560	266	650	400	10.2	cast stainless steel	184	D
DOL55/415/AL	55	560	560	266	650	400	10.2	cast aluminium	72	D
DOL55/415/CI	55	560	560	266	650	400	10.2	cast iron	172	D
DOL55/415/SS	55	560	560	266	650	400	10.2	cast stainless steel	184	D
DOLSD55/240/AL	55	560	560	266	650	400	10.2	cast aluminium	72	D
DOLSD55/240/CI	55	560	560	266	650	400	10.2	cast iron	172	D
DOLSD55/240/SS	55	560	560	266	650	400	10.2	cast stainless steel	184	D
DOLSD55/415/AL	55	560	560	266	650	400	10.2	cast aluminium	72	D
DOLSD55/415/CI	55	560	560	266	650	400	10.2	cast iron	172	D
DOLSD55/415/SS	55	560	560	266	650	400	10.2	cast stainless steel	184	D
DOL75/240/AL	75	560	560	266	650	400	10.2	cast aluminium	72	D
DOL75/240/CI	75	560	560	266	650	400	10.2	cast iron	172	D
DOL75/240/SS	75	560	560	266	650	400	10.2	cast stainless steel	184	D
DOL75/415/AL	75	560	560	266	650	400	10.2	cast aluminium	72	D
DOL75/415/CI	75	560	560	266	650	400	10.2	cast iron	172	D
DOL75/415/SS	75	560	560	266	650	400	10.2	cast stainless steel	184	D
DOLSD75/240/AL	75	560	560	266	650	400	10.2	cast aluminium	72	D
DOLSD75/240/CI	75	560	560	266	650	400	10.2	cast iron	172	D
DOLSD75/240/SS	75	560	560	266	650	400	10.2	cast stainless steel	184	D
DOLSD75/415/AL	75	560	560	266	650	400	10.2	cast aluminium	72	D
DOLSD75/415/CI	75	560	560	266	650	400	10.2	cast iron	172	D
DOLSD75/415/SS	75	560	560	266	650	400	10.2	cast stainless steel	184	D

1 Reference drawings see at first page of DOL / DOLSD

Release date 2013-03-20 - AO

DOL/DOLSD - Mechanical Specification

Type	Power	Cable entries		Cover fixing screws	Ingress protection	Seal	Enclosure material
	[kW]	Face [A]	Face [B]	Stainless steel	EN60529	see *1*	
DOL1.1/240	1.1	1 x M20	2 x M20	M6	IP65	1	cast iron
DOL1.5/240	1.5	1 x M20	2 x M20	M6	IP65	1	cast iron
DOL2.2/240	2.2	1 x M20	2 x M20	M6	IP65	1	cast iron
DOL3/240	3	1 x M20	2 x M20	M6	IP65	1	cast iron
DOL4/240	4	1 x M20	2 x M20	M6	IP65	1	cast iron
DOL4/415	4	1 x M20	2 x M20	M6	IP65	1	cast iron
DOL5.5/240	5.5	1 x M20	2 x M20	M6	IP65	1	cast iron
DOL5.5/415	5.5	1 x M20	2 x M20	M6	IP65	1	cast iron
DOL7.5/240	7.5	1 x M20	2 x M20	M6	IP65	1	cast iron
DOL7.5/415	7.5	1 x M20	2 x M20	M6	IP65	1	cast iron
DOL11/240/AL	11	1 x M20	2 x M20	M8	IP66	2	cast aluminium
DOL11/240/CI	11	1 x M20	2 x M20	M8	IP66	2	cast iron
DOL11/240/SS	11	1 x M20	2 x M20	M8	IP66	2	cast stainless steel
DOL11/415/AL	11	1 x M20	2 x M20	M8	IP66	2	cast aluminium
DOL11/415/CI	11	1 x M20	2 x M20	M8	IP66	2	cast iron
DOL11/415/SS	11	1 x M20	2 x M20	M8	IP66	2	cast stainless steel
DOL15/240/AL	15	1 x M20	2 x M20	M8	IP66	2	cast aluminium
DOL15/240/CI	15	1 x M20	2 x M20	M8	IP66	2	cast iron
DOL15/240/SS	15	1 x M20	2 x M20	M8	IP66	2	cast stainless steel
DOL15/415/AL	15	1 x M20	2 x M20	M8	IP66	2	cast aluminium
DOL15/415/CI	15	1 x M20	2 x M20	M8	IP66	2	cast iron
DOL15/415/SS	15	1 x M20	2 x M20	M8	IP66	2	cast stainless steel
DOL18.5/240/AL	18.5	1 x M25	2 x M25	M8	IP66	2	cast aluminium
DOL18.5/240/CI	18.5	1 x M25	2 x M25	M8	IP66	2	cast iron
DOL18.5/240/SS	18.5	1 x M25	2 x M25	M6	IP66	1	cast stainless steel
DOL18.5/415/AL	18.5	1 x M25	2 x M25	M8	IP66	2	cast aluminium
DOL18.5/415/CI	18.5	1 x M25	2 x M25	M8	IP66	2	cast iron
DOL18.5/415/SS	18.5	1 x M25	2 x M25	M6	IP66	1	cast stainless steel
DOL22/240/AL	22	1 x M25	2 x M25	M8	IP66	2	cast aluminium
DOL22/240/CI	22	1 x M25	2 x M25	M8	IP66	2	cast iron
DOL22/240/SS	22	1 x M25	2 x M25	M6	IP66	1	cast stainless steel
DOL22/415/AL	22	1 x M25	2 x M25	M8	IP66	2	cast aluminium
DOL22/415/CI	22	1 x M25	2 x M25	M8	IP66	2	cast iron
DOL22/415/SS	22	1 x M25	2 x M25	M6	IP66	1	cast stainless steel
DOLSD22/240/SS	22	1 x M25	2 x M25	M8	IP66	1	cast stainless steel
DOLSD22/240/AL	22	1 x M25	2 x M25	M8	IP66	1	cast aluminium
DOLSD22/240/CI	22	1 x M25	2 x M25	M8	IP66	1	cast iron
DOLSD22/415/AL	22	1 x M25	2 x M25	M8	IP66	1	cast aluminium
DOLSD22/415/CI	22	1 x M25	2 x M25	M8	IP66	1	cast iron
DOLSD22/415/SS	22	1 x M25	2 x M25	M8	IP66	1	cast stainless steel

Table continues overleaf

Release date 2013-03-20 - AO

This datasheet does not constitute any contract obligation.

Pepperl+Fuchs reserves the right to modify the products herein illustrated without prior notice. Copyright Pepperl+Fuchs srl - Italy: +39 039 6292 1

DOL/DOLSD - Mechanical Specification continued

Type	Power [kW]	Cable entries		Cover fixing screws Stainless steel	Ingress protection EN60529	Seal see *1*	Enclosure material
		Face [A]	Face [B]				
DOL30/240/AL	30	1 x M25	2 x M25	M8	IP66	2	cast aluminium
DOL30/240/CI	30	1 x M25	2 x M25	M8	IP66	2	cast iron
DOL30/240/SS	30	1 x M25	2 x M25	M6	IP66	1	cast stainless steel
DOL30/415/AL	30	1 x M25	2 x M25	M8	IP66	2	cast aluminium
DOL30/415/CI	30	1 x M25	2 x M25	M8	IP66	2	cast iron
DOL30/415/SS	30	1 x M25	2 x M25	M6	IP66	1	cast stainless steel
DOLSD30/240/AL	30	1 x M25	2 x M25	M8	IP66	1	cast aluminium
DOLSD30/240/CI	30	1 x M25	2 x M25	M8	IP66	1	cast iron
DOLSD30/240/SS	30	1 x M25	2 x M25	M8	IP66	1	cast stainless steel
DOLSD30/415/AL	30	1 x M25	2 x M25	M8	IP66	1	cast aluminium
DOLSD30/415/CI	30	1 x M25	2 x M25	M8	IP66	1	cast iron
DOLSD30/415/SS	30	1 x M25	2 x M25	M8	IP66	1	cast stainless steel
DOL55/240/AL	55	1 x M32	2 x M32	M10	IP66	1	cast aluminium
DOL55/240/CI	55	1 x M32	2 x M32	M10	IP66	1	cast iron
DOL55/240/SS	55	1 x M32	2 x M32	M10	IP66	1	cast stainless steel
DOL55/415/AL	55	1 x M32	2 x M32	M10	IP66	1	cast aluminium
DOL55/415/CI	55	1 x M32	2 x M32	M10	IP66	1	cast iron
DOL55/415/SS	55	1 x M32	2 x M32	M10	IP66	1	cast stainless steel
DOLSD55/240/AL	55	1 x M32	2 x M32	M10	IP66	1	cast aluminium
DOLSD55/240/CI	55	1 x M32	2 x M32	M10	IP66	1	cast iron
DOLSD55/240/SS	55	1 x M32	2 x M32	M10	IP66	1	cast stainless steel
DOLSD55/415/AL	55	1 x M32	2 x M32	M10	IP66	1	cast aluminium
DOLSD55/415/CI	55	1 x M32	2 x M32	M10	IP66	1	cast iron
DOLSD55/415/SS	55	1 x M32	2 x M32	M10	IP66	1	cast iron
DOL75/240/AL	75	1 x M40	2 x M40	M10	IP66	1	cast aluminium
DOL75/240/CI	75	1 x M40	2 x M40	M10	IP66	1	cast iron
DOL75/240/SS	75	1 x M40	2 x M40	M10	IP66	1	cast stainless steel
DOL75/415/AL	75	1 x M40	2 x M40	M10	IP66	1	cast aluminium
DOL75/415/CI	75	1 x M40	2 x M40	M10	IP66	1	cast iron
DOL75/415/SS	75	1 x M40	2 x M40	M10	IP66	1	cast stainless steel
DOLSD75/240/AL	75	1 x M40	2 x M40	M10	IP66	1	cast aluminium
DOLSD75/240/CI	75	1 x M40	2 x M40	M10	IP66	1	cast iron
DOLSD75/240/SS	75	1 x M40	2 x M40	M10	IP66	1	cast stainless steel
DOLSD75/415/AL	75	1 x M40	2 x M40	M10	IP66	1	cast aluminium
DOLSD75/415/CI	75	1 x M40	2 x M40	M10	IP66	1	cast iron
DOLSD75/415/SS	75	1 x M40	2 x M40	M10	IP66	1	cast stainless steel

1 Seal:

1 - Seal by grease

2 - One piece closed cell neoprene

Release date 2013-03-20 - AO

This datasheet does not constitute any contract obligation.

Pepperl+Fuchs reserves the right to modify the products herein illustrated without prior notice. Copyright Pepperl+Fuchs srl - Italy: +39 039 6292 1

Pepperl+Fuchs Group
www.pepperl-fuchs.com

USA: +1 330 486 0002
pa-info@us.pepperl-fuchs.com

Germany: +49 621 776 2222
pa-info@de.pepperl-fuchs.com

Singapore: +65 6779 9091
pa-info@sg.pepperl-fuchs.com



Description:

The SDS range of star delta motor starters are safely protected in flameproof enclosures. They are suitable for Ex e motors and available with various contactor ratings and coil voltages.

Application:

The SDS range of motor starters is designed for safe operation of machinery and drives in gas or dust explosion hazardous areas.

Materials:

Body: Cast iron, aluminium and stainless steel.
Screws: Stainless steel.
For details see data tables overleaf.

Certification characteristics:

Marking to 94/9/EC: II 2GD
Zones: 1 – 21 – 2 – 22

For type of protection, certificates and ambient temperature range please see certification characteristics table overleaf.

Threads:

Metric threaded, for details see Mechanical Specification.

Inhibiting treatments:

Zinc rich epoxy powder primer plus epoxy powder top coat black.

Features:

Enclosure cover: hinged non-detachable
Mounting: 2 x fabricated stainless steel mounting straps.

Mechanical Specification:

For drawing references, dimensions [mm] and approx. weight [kg] see Dimensions Data Table.

Cable entries (dimension F):

Face [A]: 1 x M25
Face [B]: 1 x M20, 2 x M25
Cover fixing screws: M8 stainless steel
Ingress protection to EN60529: IP66
Seal: One piece closed cell neoprene.

Drawing SDS

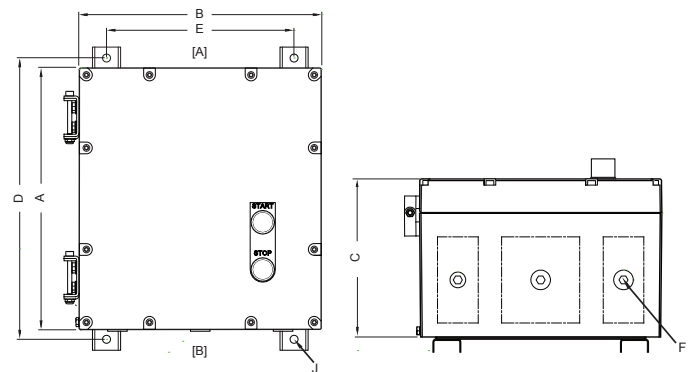

Legend:

- A - Maximum external dimension.
- B - Maximum external dimension.
- C - Maximum external dimension.
- D - Fixing holes wheel base.
- E - Fixing holes wheel base.
- F - Cable entry diameter.
- J - Fixing holes diameter.
- [A] - Entry face.
- [B] - Entry face.

For details see Dimensions Data Table.

SDS - Electrical Specification

Type	Power	Current AC3	Coil Voltage	Terminal capacity		Overload relay	Enclosure material
	[kW]	[V]	[V]	[mm ²] *1*	[mm ²] *2*	[A]	
SDS11/240/AL	11	22	240	6	9.6	15 ... 26	cast aluminium
SDS11/240/CI	11	22	240	6	9.6	15 ... 26	cast iron
SDS11/240/SS	11	22	240	6	9.6	15 ... 26	cast stainless steel
SDS11/415/AL	11	22	415	6	9.6	15 ... 26	cast aluminium
SDS11/415/CI	11	22	415	6	9.6	15 ... 26	cast iron
SDS11/415/SS	11	22	415	6	9.6	15 ... 26	cast stainless steel
SDS15/240/AL	15	29	240	6	9.6	24 ... 40	cast aluminium
SDS15/240/CI	15	29	240	6	9.6	24 ... 40	cast iron
SDS15/240/SS	15	29	240	6	9.6	24 ... 40	cast stainless steel
SDS15/415/AL	15	29	415	6	9.6	24 ... 40	cast aluminium
SDS15/415/CI	15	29	415	6	9.6	24 ... 40	cast iron
SDS15/415/SS	15	29	415	6	9.6	24 ... 40	cast stainless steel
SDS22/240/AL	22	43	240	10	16	30 ... 45	cast aluminium
SDS22/240/CI	22	43	240	10	16	30 ... 45	cast iron
SDS22/240/SS	22	43	240	10	16	30 ... 45	cast stainless steel
SDS22/415/AL	22	43	415	10	16	30 ... 45	cast aluminium
SDS22/415/CI	22	43	415	10	16	30 ... 45	cast iron
SDS22/415/SS	22	43	415	10	16	30 ... 45	cast stainless steel
SDS30/240/AL	30	55	240	25	40	35 ... 57	cast aluminium
SDS30/240/CI	30	55	240	25	40	35 ... 57	cast iron
SDS30/240/SS	30	55	240	25	40	35 ... 57	cast stainless steel
SDS30/415/AL	30	55	415	25	40	35 ... 57	cast aluminium
SDS30/415/CI	30	55	415	25	40	35 ... 57	cast iron
SDS30/415/SS	30	55	415	25	40	35 ... 57	cast stainless steel

Phases: 3

Grounding: internal & external brass grounding terminals on base and lid

1 for flexible cable

2 for solid cable

SDS - Certification characteristics

Marking to 94/9/EC

II 2 GD

Type of protection

1.1 Ex d IIB T6 Gb, Ex tb IIIC T76 °C Db (ta ... +50 °C)

1.2 Ex d IIB T5 Gb, Ex tb IIIC T82 °C Db (ta ... +55 °C)

Certificate

2.1 SIRA 04 ATEX 1266X

Ambient temperature

3.1 -40 ... 55 °C (-40 ... 131 °F)

IECEx approval

4.1 IECEx SIR 08.0056X

GOST-R approval

5.1 GOST-R B00218

SDS - Dimensions Data Table

Type	Power [kW]	Dimensions [mm]			Fixation [mm]			Enclosure material	Weight approx. [kg]
		A	B	C	D	E	Diam. J		
SDS11/240/AL	11	335	310	205	360	240	10.2	cast aluminium	19
SDS11/240/CI	11	335	310	205	360	240	10.2	cast iron	50
SDS11/240/SS	11	335	310	205	360	240	10.2	cast stainless steel	52
SDS11/415/AL	11	335	310	205	360	240	10.2	cast aluminium	19
SDS11/415/CI	11	335	310	205	360	240	10.2	cast iron	50
SDS11/415/SS	11	335	310	205	360	240	10.2	cast stainless steel	52
SDS15/240/AL	15	335	310	205	360	240	10.2	cast aluminium	19
SDS15/240/CI	15	335	310	205	360	240	10.2	cast iron	50
SDS15/240/SS	15	335	310	205	360	240	10.2	cast stainless steel	52
SDS15/415/AL	15	335	310	205	360	240	10.2	cast aluminium	19
SDS15/415/CI	15	335	310	205	360	240	10.2	cast iron	50
SDS15/415/SS	15	335	310	205	360	240	10.2	cast stainless steel	52
SDS22/240/AL	22	335	310	205	360	240	10.2	cast aluminium	19
SDS22/240/CI	22	335	310	205	360	240	10.2	cast iron	50
SDS22/240/SS	22	335	310	205	360	240	10.2	cast stainless steel	52
SDS22/415/AL	22	335	310	205	360	240	10.2	cast aluminium	19
SDS22/415/CI	22	335	310	205	360	240	10.2	cast iron	50
SDS22/415/SS	22	335	310	205	360	240	10.2	cast stainless steel	52
SDS30/240/AL	30	335	310	205	360	240	10.2	cast aluminium	19
SDS30/240/CI	30	335	310	205	360	240	10.2	cast iron	50
SDS30/240/SS	30	335	310	205	360	240	10.2	cast stainless steel	52
SDS30/415/AL	30	335	310	205	360	240	10.2	cast aluminium	19
SDS30/415/CI	30	335	310	205	360	240	10.2	cast iron	50
SDS30/415/SS	30	335	310	205	360	240	10.2	cast stainless steel	52

Reference drawing see at first page SDS

Release date 2013-03-20 - A0

This datasheet does not constitute any contract obligation.

Pepperl+Fuchs reserves the right to modify the products herein illustrated without prior notice. Copyright Pepperl+Fuchs srl - Italy: +39 039 6292 1

Pepperl+Fuchs Group
www.pepperl-fuchs.com

USA: +1 330 486 0002
pa-info@us.pepperl-fuchs.com

Germany: +49 621 776 2222
pa-info@de.pepperl-fuchs.com

Singapore: +65 6779 9091
pa-info@sg.pepperl-fuchs.com



GUB RANGE

Ex d IIC

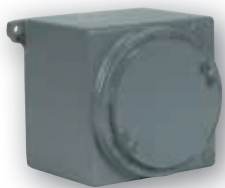

Enclosures with blind threaded cover manufactured in aluminium alloy

▶ P. 63-65

GUB/W RANGE

Ex d IIC

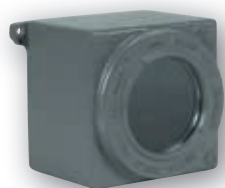

Enclosures with threaded cover with circular port-hole manufactured in aluminium alloy

▶ P. 67-69

GUB/E RANGE

Ex d IIC

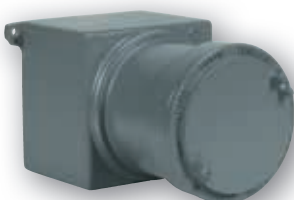

Enclosures with extension and threaded cover with circular port-hole manufactured in aluminium alloy

▶ P. 71-73

GUB/WE RANGE

Ex d IIC



Enclosures with extension and blind threaded cover manufactured in aluminium alloy

▶ P. 75-77

GUB/X RANGE

Ex d IIC



Enclosures with flanged cover and windows manufactured in stainless steel

▶ P. 79-81

This datasheet does not constitute any contract obligation.

Pepperl+Fuchs reserves the right to modify the products herein illustrated without prior notice. Copyright Pepperl+Fuchs srl - Italy: +39 039 6292 1

Pepperl+Fuchs Group
www.pepperl-fuchs.comUSA: +1 330 486 0002
pa-info@us.pepperl-fuchs.comGermany: +49 621 776 2222
pa-info@de.pepperl-fuchs.comSingapore: +65 6779 9091
pa-info@sg.pepperl-fuchs.com

PEPPERL+FUCHS
 PROTECTING YOUR PROCESS



Description:

The GUB enclosures are made of aluminium alloy, square shaped and have a blind threaded cover. Please refer to the products GUB/W, GUB/WE and GUB/E showing these enclosures with a port-hole and / or an extension.

Application:

The enclosures are suitable to contain terminals, contactors, switches, transformers, capacitors, PLC and other electric, electronic equipment and intrinsic safety devices.

Materials:

Body, cover and extension: copper free aluminium alloy.
Screws: stainless steel.

Certification characteristics:

Type of Protection: II 2GD Ex d IIC Gb / Ex tb IIIC Db
II 2GD Ex d [i. G.] IIC T6 Gb / Ex tb [i.D] IIIC T85. °C Db.
Class of Temperature: T6/T85 °C → T3/T200 °C.
Protection Degree: IP65 / IP67*.
Certificate: INERIS 10ATEX0036.
Ambient Temp.: -50 °C / +60 °C (-20 / +40 / +50 / +55 °C).
Zones: 1 – 21 – 2 – 22.

Threads:

NPT (ANSI B1.20.1).
Metric x 1.5 (ISO 261).

Inhibiting treatments:

Standard epoxy painting RAL 7005.

On request:

*IP67 protection with o-ring.
Galvanized steel equipment plate.
Pushbuttons, pilot light, selector switches.
Breathing / draining valve.
Wiring.
Other epoxy painting colours different from the standards.
Special inhibiting treatment.
Other type of threads [ISO7/1 (UNI6125), PG (DIN 40430)].
Cable glands for armoured or non armoured cable.

Drawing GUB

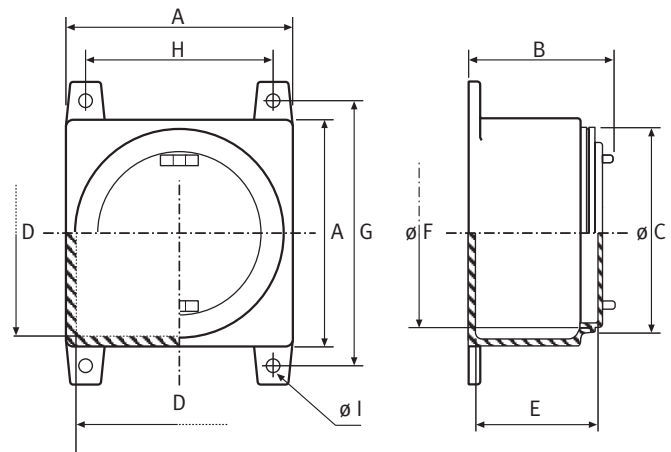

Legend:

- A - Maximum external dimension.
- B - Maximum external dimension with cover.
- Ø C - Cover external diameter.
- D - Internal dimension.
- E - Internal depth.
- Ø F - Body access diameter.
- G - Fixing holes wheel base.
- H - Fixing holes wheel base.
- Ø I - Fixing holes diameter.

Grounding:

External: M6 grounding point (GUB complete serie).
Internal: M5 grounding point (GUBØØ → GUB 3L).
M6 grounding point (GUB 4 → GUB 5).

GUB - Data Table

Dimensions [mm] and approx. Weight [Kg]

Type	Dimensions						Fixing			Weight
	External			Internal			G	H	Ø I	
	A	B	Ø C	D	E	Ø F				
GUB 00	119	137	112	92	98	97	145	95	2 x 8	2
GUB 0	150	150	136	125	115	114	178	125	2 x 8	3,5
GUB 0H	150	190	136	125	152	114	178	125	2 x 8	4,5
GUB 1	200	160	189	170	112	163	228	178	2 x 10	6,4
GUB 1H	200	200	189	170	152	163	228	178	2 x 10	7,6
GUB 1PF	176	139	170	150	105	147	196	154	2 x 10	6,4
GUB 2	250	160	231	225	116	206	275	232	4 x 10	8,5
GUB 3	250	205	231	225	158	206	285	228	4 x 10	10,7
GUB 3L	360	245	348	325	185	320	395	318	4 x 10	21
GUB 4	450	305	437	410	230	406	485	410	4 x 10	42
GUB 4A	450	235	437	410	160	406	485	410	4 x 10	37
GUB 5	550	360	536	510	270	504	595	513	4 x 10	60,5

Note: - dimensions can slightly differ due to casting model tolerances, - all enclosures are available with o-ring for IP67 protection degree
 - GUB 5 not available with minimum ambient temperature: -50 °C, - till GUB1PF, the enclosures have only two fixing brackets.

GUB - Drilling Table

Type	Cover	Body (holes for each side)								
	1/4"	1/2"	3/4"	1"	1.1/4"	1.1/2"	2"	2.1/2"	3"	4"
GUB 00	1	4	3	2	1	1	1	-	-	-
GUB 0	1	6	5	3	2	2	1	1	-	-
GUB 0H	1	8	8	5	3	3	1	1	1	-
GUB 1	2	8	8	5	4	3	2	1	1	-
GUB 1PF	1	8	8	5	3	3	1	1	1	-
GUB 1H	2	8	8	5	4	4	2	1	1	-
GUB 2	3	10	10	5	4	3	3	2	-	-
GUB 3	3	15	15	8	6	6	3	2	2	-
GUB 3L	8	18	17	11	8	8	5	3	2	1
GUB 4	10	21	21	18	14	14	8	5	4	1
GUB 4A	10	20	17	12	10	10	4	3	3	-
GUB 5	12	32	30	26	17	14	8	5	4	1

GUB - Bottom Drilling Table

Type	1/2"	3/4"	1"	1.1/4"	1.1/2"
GUB 00	1	1	1	-	-
GUB 0	2	2	1	-	-
GUB 0H	2	2	1	-	-
GUB 1	2	2	2	-	-
GUB 1PF	2	2	1	-	-
GUB 1H	2	2	2	-	-
GUB 2	10	2	2	-	-
GUB 3	10	3	2	-	-
GUB 3L	3	3	2	-	-
GUB 4	3	3	3	3	3
GUB 4A	3	3	3	3	3
GUB 5	6	6	4	3	3

Note: - available cable entry with 1/4" and 3/8" diameter (or other equivalent thread type) with the same maximum number of 1/2" holes.
 - The cable entries with Metric (x 1.5) threads are equivalent in number with the inches threads listed in the above table.
 - The comparison between Metric (x 1.5) and inches is according to the following table.

Release date 2011-01-24 - Updated 2013-04-19 - A5

This datasheet does not constitute any contract obligation.

Pepperl+Fuchs reserves the right to modify the products herein illustrated without prior notice. Copyright Pepperl+Fuchs srl - Italy: +39 039 6292 1

GUB - Threads Comparison Table

Inches	1/4"	3/8"	1/2"	3/4"	1"	1 1/4"	1 1/2"	2"	2 1/2"	3"	4"
Metric (x 1.5)	M12	M16	M20	M25	M32	M40/M42	M50	M63	M75	M85	n.a.

GUB - Mounting Plates

Dimensions [mm]

MODEL	Type code	A	B	C	D	E	F	Ø G	Th (1)
GUB 0	-	-	-	-	-	-	-	-	-
GUB 0H	-	-	-	-	-	-	-	-	-
GUB 1	PPG 1	10	25	120	130	150	145	7 (2)	2
GUB 1H	PPG 1	10	25	120	130	150	145	7 (2)	2
GUB 1PF	PPG 1PF	10	25	80	105	125	125	7 (2)	2
GUB 2	PPG 2	15	30	150	150	185	185	7 (2)	2
GUB 3	PPG 3	15	30	150	150	185	185	7 (2)	2
GUB 3L	PPG 3L	20	30	110	270	290	290	7 (3)	2
GUB 4	PPG 4	20	20	140	345	360	360	7 (3)	2
GUB 4A	PPG 4A	55	55	140	345	360	360	7 (3)	2
GUB 5	PPG 5	30	30	163	420	440	440	7 (3)	2

- Notes: (1) - Th = Thickness [mm]
 (2) - 2 fixing holes, 1 upper left side, 1 lower right side
 (3) - 4 fixing holes.

GUB - Mounting Plates in galvanised steel

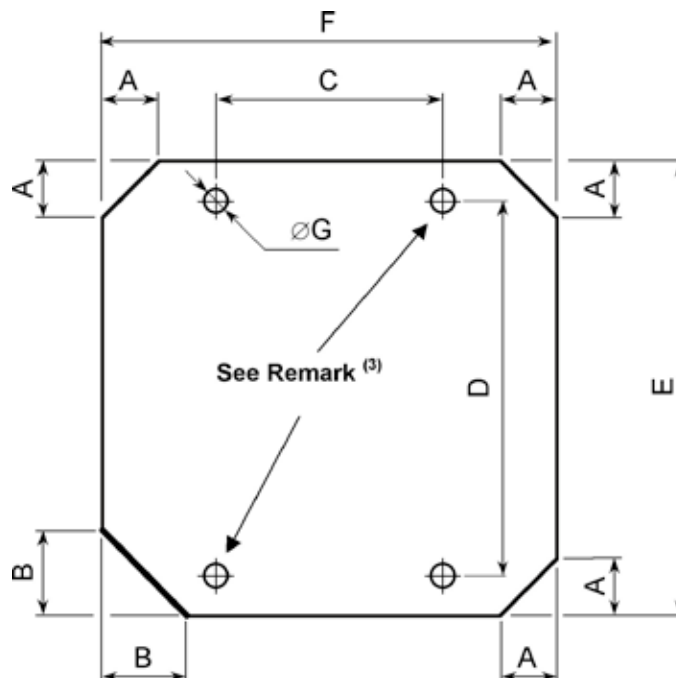

Note: the positioning of the mounting plate reported here above is purely as an example, the location of the earth screw depends on the type of enclosure.

Release date 2011-01-24 – Updated 2013-04-19 - A5



This datasheet does not constitute any contract obligation.

Pepperl+Fuchs reserves the right to modify the products herein illustrated without prior notice. Copyright Pepperl+Fuchs srl - Italy: +39 039 6292 1

Description:

The GUB/W enclosures are made of aluminium alloy, square shaped and complete with a threaded cover with circular port-hole (W) for visualization.

Application:

The enclosures are suitable to contain terminals, contactors, switches, transformers, capacitors, PLC and other electric, electronic equipment and intrinsic safety devices.

Materials:

Body and cover: copper free aluminium alloy.
Screws: stainless steel.
Porthole: thermo-resistant tempered glass.

Certification characteristics:

Type of Protection: II 2GD Ex d IIC Gb / Ex tb IIIC Db
II 2GD Ex d [i. G.] IIC T6 Gb / Ex tb [i.D] IIIC T85°C Db.
Class of Temperature: T6/T85 °C → T3/T200 °C.
Protection Degree: IP65 / IP67*.
Certificate: INERIS 10ATEX0036.
Ambient Temp.: -50 °C / +60 °C (-20 / +40 / +50 / +55 °C).
Zones: 1 – 21 – 2 – 22.

Threads:

NPT (ANSI B1.20.1).
Metric x 1.5 (ISO 261).

Inhibiting treatments:

Standard epoxy painting RAL 7005.

On request:

*IP67 protection with o-ring.
Galvanized steel equipment plate.
Pushbuttons, pilot light, selector switches.
Breathing / draining valve.
Wiring.
Other epoxy painting colours different from the standards.
Special inhibiting treatment.
Other type of threads [ISO7/1 (UNI6125), PG (DIN 40430)].
Cable glands for armoured or non armoured cable.

Drawing GUB/W

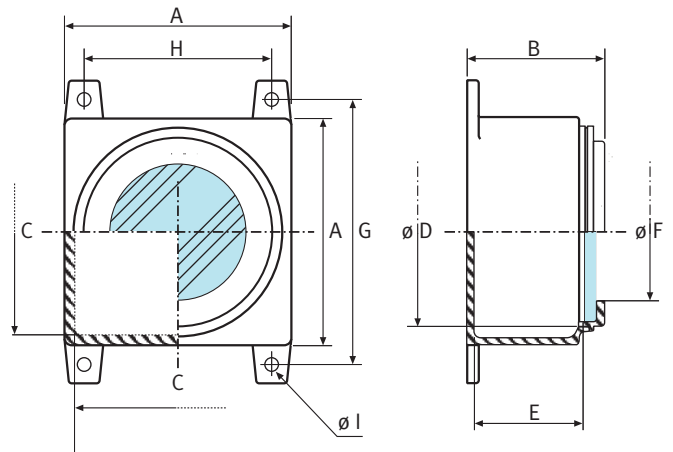

Legend:

- A - Maximum external dimension.
- B - Maximum external dimension with cover.
- C - Internal dimension.
- Ø D - Body access diameter.
- E - Internal dimension.
- Ø F - Port-hole diameter.
- G - Fixing holes wheel base.
- H - Fixing holes wheel base.
- Ø I - Fixing holes diameter.

Grounding:

External: M6 grounding point (GUB complete serie).
Internal: M5 grounding point (GUBØØ → GUB 3L).
M6 grounding point (GUB 4 → GUB 5).

GUB/W - Data Table

Dimensions [mm] and approx. Weight [Kg]

Type	Dimensions					Port-hole Ø F	Fixing			Weight
	External		Internal				G	H	Ø I	
	A	B	C	Ø D	E					
GUB/W 00	119	125	92	97	86	63	145	95	2 x 8	2,1
GUB/W 0	150	135	125	114	112	79	178	125	2 x 8	3,6
GUB/W 0H	150	175	125	114	146	79	178	125	2 x 8	4,6
GUB/W 1	200	140	170	163	103	121	228	178	2 x 10	6,3
GUB/W 1H	200	180	170	163	143	121	228	178	2 x 10	7,5
GUB/W 2	250	140	225	206	100	160	275	232	4 x 10	9
GUB/W 3	250	185	225	206	143	160	285	228	4 x 10	11
GUB/W 3L	360	225	325	320	162	260	395	318	4 x 10	22
GUB/W 4	450	290	410	406	205	260	485	410	4 x 10	44
GUB/W 4A	450	220	410	406	135	260	485	410	4 x 10	39
GUB/W 5 – WG1	550	360	510	504	270	121	595	513	4 x 10	60
GUB/W 5 – WG2	550	360	510	504	270	160	595	513	4 x 10	60

Note: - dimensions can slightly differ due to casting model tolerances, - all enclosures are available with o-ring for IP67 protection degree
 - GUB 5 not available with minimum ambient temperature: -50 °C, - till GUB/W1H, the enclosures have only two fixing brackets.

GUB/W - Drilling Table

Type	Body (holes for each side)								
	1/2"	3/4"	1"	1.1/4"	1.1/2"	2"	2.1/2"	3"	4"
GUB/W 00	4	3	2	1	1	1	-	-	-
GUB/W 0	6	5	3	2	2	1	1	-	-
GUB/W 0H	8	8	5	3	3	1	1	1	-
GUB/W 1	8	8	5	4	3	2	1	1	-
GUB/W 1H	8	8	5	4	4	2	1	1	-
GUB/W 2	10	10	5	4	3	3	2	-	-
GUB/W 3	15	15	8	6	6	3	2	2	-
GUB/W 3L	18	17	11	8	8	5	3	2	1
GUB/W 4	21	21	18	14	14	8	5	4	1
GUB/W 4A	20	17	12	10	10	4	3	3	-
GUB/W 5 – WG1	32	30	26	17	14	8	5	4	1
GUB/W 5 – WG2	32	30	26	17	14	8	5	4	1

GUB/W - Bottom Drilling Table

Type	1/2"	3/4"	1"	1.1/4"	1.1/2"
GUB/W 00	1	1	1	-	-
GUB/W 0	2	2	1	-	-
GUB/W0H	2	2	1	-	-
GUB/W 1	2	2	2	-	-
GUB/W 1H	2	2	2	-	-
GUB/W 2	10	2	2	-	-
GUB/W 3	10	3	2	-	-
GUB/W3L	3	3	2	-	-
GUB/W 4	3	3	3	3	3
GUB/W 4A	3	3	3	3	3
GUB/W 5 – WG1	6	6	4	3	3
GUB/W 5 – WG2	6	6	4	3	3

Note: - available cable entry with 1/4" and 3/8" diameter (or other equivalent thread type) with the same maximum number of 1/2" holes.
 - the cable entries with Metric (x 1.5) threads are equivalent in number with the inches threads listed in the above table.
 The comparison between Metric (x 1.5) and inches is according to the following table.

Release date 2011-01-24 – Updated 2013-04-19 - A4

GUB - Threads Comparison Table

Inches	1/4"	3/8"	1/2"	3/4"	1"	1 1/4"	1 1/2"	2"	2 1/2"	3"	4"
Metric (x 1.5)	M12	M16	M20	M25	M32	M40/M42	M50	M63	M75	M85	n.a.

GUB/W - Mounting Plates

Dimensions [mm]

MODEL	Type code	A	B	C	D	E	F	Ø G	Th (1)
GUB/W 00	-	-	-	-	-	-	-	-	-
GUB/W 0	-	-	-	-	-	-	-	-	-
GUB/W 0H	-	-	-	-	-	-	-	-	-
GUB/W 1	PPG 1	10	25	120	130	150	145	7 (2)	2
GUB/W 1H	PPG 1	10	25	120	130	150	145	7 (2)	2
GUB/W 2	PPG 2	15	30	150	150	185	185	7 (2)	2
GUB/W 3	PPG 3	15	30	150	150	185	185	7 (2)	2
GUB/W 3L	PPG 3L	20	30	110	270	290	290	7 (3)	2
GUB/W 4	PPG 4	20	20	140	345	360	360	7 (3)	2
GUB/W 4A	PPG 4A	55	55	140	345	360	360	7 (3)	2
GUB/W 5	PPG 5	30	30	163	420	440	440	7 (3)	2

Note: (1) - Th = Thickness [mm]
 (2) - 2 fixing holes, 1 upper left side, 1 lower right side
 (3) - 4 fixing holes.

GUB - Mounting Plates Drawing in galvanized steel

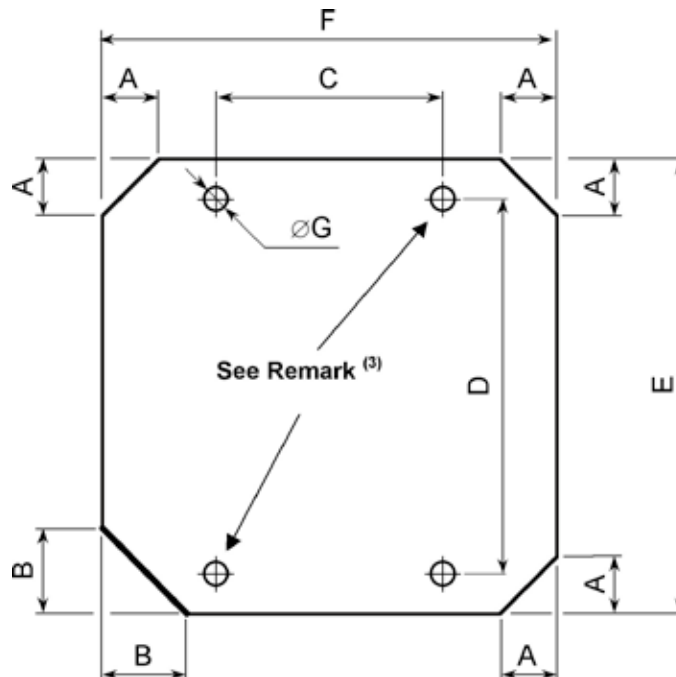

Note: the positioning of the mounting plate reported here above is purely as an example, the location of the earth screw depends on the type of enclosure.

Release date 2011-01-24 – Updated 2013-04-19 - A4



Description:

The GUB/E enclosures are made of aluminium alloy, square shaped and complete with an extension (E) and a blind threaded cover. Please refer to the datasheets of our products GUB/WE showing this enclosure with a cover with a port-hole.

Application:

The enclosures are suitable to contain terminals, contactors, switches, transformers, capacitors, PLC and other electric, electronic equipment and intrinsic safety devices.

Materials:

Body and cover: copper free aluminium alloy.
Screws: stainless steel.

Certification characteristics:

Type of Protection: II 2GD Ex d IIC Gb / Ex tb IIIC Db
II 2GD Ex d [i. G.] IIC T6 Gb / Ex tb [i.D] IIIC T85 °C Db.
Class of Temperature: T6/T85 °C → T3/T200 °C.
Protection Degree: IP65 / IP67*.
Certificate: INERIS 10ATEX0036.
Ambient Temperature: -50 °C / +60 °C (-20 / +40 / +50 / +55 °C).
Zones: 1 – 21 – 2 – 22.

Threads:

NPT (ANSI B1.20.1).
Metric x 1.5 (ISO 261).

Inhibiting treatments:

Standard epoxy painting RAL 7005.

On request:

*IP67 protection with o-ring.
Galvanized steel equipment plate.
Superior circular plate.
Pushbuttons, pilot light, selector switches.
Breathing / draining valve.
Wiring.
Other epoxy painting colours different from the standards.
Special inhibiting treatment.
Other type of threads [ISO7/1 (UNI6125), PG (DIN 40430)].
Cable glands for armoured or non armoured cable.

Drawing GUB/E

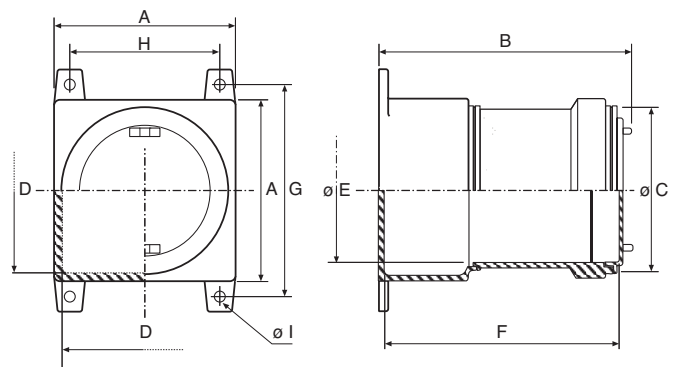

Legend:

- A - Maximum external dimension.
- B - Maximum external dimension with cover.
- Ø C - Cover external diameter.
- D - Internal dimension.
- Ø E - Extension access diameter.
- F - Internal depth.
- G - Fixing holes wheel base.
- H - Fixing holes wheel base.
- Ø I - Fixing holes diameter.

Grounding:

Grounding:

External: M6 grounding point (GUB complete serie).
Internal: M5 grounding point (GUBØ → GUB 3L).
M6 grounding point (GUB 4, GUB 4A).

GUB/E - Data Table

Dimensions [mm] and approx. Weight [Kg]

Type	Dimensions						Fixing			Weight
	External			Internal			G	H	Ø I	
	A	B	Ø C	D	Ø E	F				
GUB/E 0	150	255	136	125	102	215	178	125	2 x 8	2,3
GUB/E 0H	150	295	136	125	102	255	178	125	2 x 8	4,8
GUB/E 1	200	300	189	170	146	255	228	178	2 x 10	9,1
GUB/E 1H	200	340	189	170	146	295	228	178	2 x 10	10,4
GUB/E 2	250	340	231	225	190	295	275	232	4 x 10	13
GUB/E 3	250	385	231	225	190	335	285	228	4 x 10	15,2
GUB/E B3L	360	410	348	325	300	345	395	318	4 x 10	32,5
GUB/E 3L	360	500	348	325	300	435	395	318	4 x 10	35
GUB/E 4	450	545	437	410	386	470	485	410	4 x 10	59
GUB/E 4A	450	475	437	410	386	395	485	410	4 x 10	54

- Note:
- dimensions can slightly differ due to casting model tolerances
 - all enclosures are available with o-ring for IP67 protection degree
 - till GUB/E 1H, the enclosures have only two fixing brackets.

GUB/E - Drilling Table

Type	Cover	Body (holes for each side)								
	1/4"	1/2"	3/4"	1"	1.1/4"	1.1/2"	2"	2.1/2"	3"	4"
GUB/E 0	1	6	5	3	2	2	1	1	-	-
GUB/E 0H	1	8	8	5	3	3	1	1	1	-
GUB/E 1	2	8	8	5	4	3	2	1	1	-
GUB/E 1H	2	8	8	5	4	4	2	1	1	-
GUB/E 2	3	10	10	5	4	3	3	2	-	-
GUB/E 3	3	15	15	8	6	6	3	2	2	-
GUB/E B3L	8	18	17	11	8	8	5	3	2	1
GUB/E 3L	8	18	17	11	8	8	5	3	2	1
GUB/E 4	10	21	21	18	14	14	8	5	4	1
GUB/E 4A	10	20	17	12	10	10	4	3	3	-

GUB/E - Bottom Drilling Table

Type	1/2"	3/4"	1"	1.1/4"	1.1/2"
GUB/E 0	2	2	1	-	-
GUB/E 0H	2	2	1	-	-
GUB/E 1	2	2	2	-	-
GUB/E 1H	2	2	2	-	-
GUB/E 2	10	2	2	-	-
GUB/E 3	10	3	2	-	-
GUB/E B3L	3	3	2	-	-
GUB/E 3L	3	3	2	-	-
GUB/E 4	3	3	3	3	3
GUB/E 4A	3	3	3	3	3

- Note:
- available cable entry with 1/4" and 3/8" diameter (or other equivalent thread type) with the same maximum number of 1/2" holes.
 - the cable entries with Metric (x 1.5) threads are equivalent in number with the inches threads listed in the above table.
- The comparison between Metric (x 1.5) and inches is according to the following table.

GUB - Threads Comparison Table

Inches	1/4"	3/8"	1/2"	3/4"	1"	1 1/4"	1 1/2"	2"	2 1/2"	3"	4"
Metric (x 1.5)	M12	M16	M20	M25	M32	M40/M42	M50	M63	M75	M85	n.a.

Release date 2011-01-24 - Updated 2012-11-20 - A4

This datasheet does not constitute any contract obligation.

Pepperl+Fuchs reserves the right to modify the products herein illustrated without prior notice. Copyright Pepperl+Fuchs srl - Italy: +39 039 6292 1

GUB/E - Mounting Plates

Dimensions [mm]

MODEL	Type code	A	B	C	D	E	F	Ø G	Th (1)
GUB/E 0	-	-	-	-	-	-	-	-	-
GUB/E 0H	-	-	-	-	-	-	-	-	-
GUB/E 1	PPG 1	10	25	120	130	150	145	7 (2)	2
GUB/E 1H	PPG 1	10	25	120	130	150	145	7 (2)	2
GUB/E 2	PPG 2	15	30	150	150	185	185	7 (2)	2
GUB/E 3	PPG 3	15	30	150	150	185	185	7 (2)	2
GUB/E B3L	PPG 3L	20	30	110	270	290	290	7 (3)	2
GUB/E 3L	PPG 3L	20	30	110	270	290	290	7 (3)	2
GUB/E 4	PPG 4	20	20	140	345	360	360	7 (3)	2
GUB/E 4A	PPG 4A	55	55	140	345	360	360	7 (3)	2

- Notes: (1) - Th = Thickness [mm]
 (2) - 2 fixing holes, 1 upper left side, 1 lower right side
 (3) - 4 fixing holes.

GUB - Mounting Plates in galvanized steel

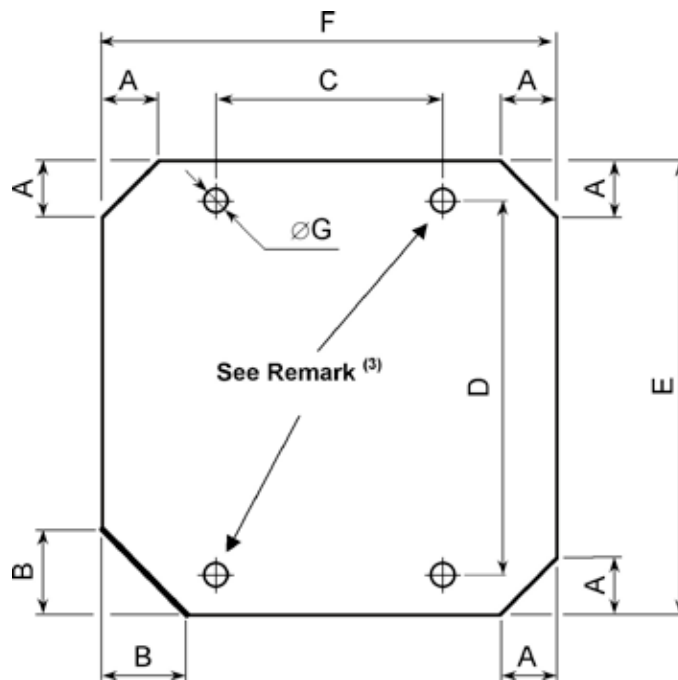

Note: the positioning of the mounting plate reported here above is purely as an example, the location of the earth screw depends on the type of enclosure.

Release date 2011-01-24 – Updated 2012-11-20 - A4



GUB/WE - Enclosure with port-hole and extension

Description:

The GUB/WE enclosures are made of aluminium alloy, square shaped and complete with an extension (E) and a threaded cover with a circular port-hole (W).

Application:

The enclosures are suitable to contain electric, electronic equipment, intrinsic safety devices and instruments to be visualized.

Materials:

Body and cover: copper free aluminium alloy.
Porthole: thermo-resistant tempered glass.
Screws: stainless steel.

Certification characteristics:

Type of Protection: II 2GD Ex d IIC Gb / Ex tb IIIC Db
II 2GD Ex d [i. G.] IIC T6 Gb / Ex tb [i. D] IIIC T85 °C Db.
Class of Temperature: T6/T85 °C → T3/T200 °C.
Protection Degree: IP65 / IP67*.
Certificate: INERIS 10ATEX0036.
Ambient Temp.: -50 °C / +60 °C (-20 / +40 / +50 / +55 °C).
Zones: 1 - 21 - 2 - 22.

Threads:

NPT (ANSI B1.20.1).
Metric x 1.5 (ISO 261).

Inhibiting treatments:

Standard epoxy painting RAL 7005.

On request:

*IP67 protection with o-ring.
Galvanized steel equipment plate.
Superior circular plate.
Pushbuttons, pilot light, selector switches.
Breathing / draining valve.
Wiring.
Other epoxy painting colours different from the standards.
Special inhibiting treatment.
Other type of threads [ISO7/1 (UNI6125), PG (DIN 40430)].
Cable glands for armoured or non armoured cable.

Drawing GUB/WE

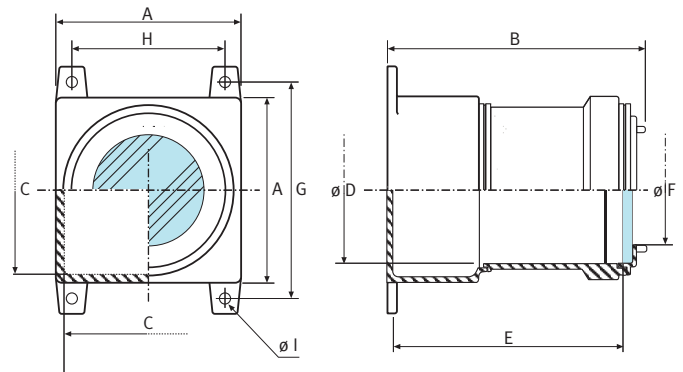

Legend:

- A - Maximum external dimension.
- B - Maximum external dimension with cover.
- C - Internal dimension.
- Ø D - Extension access diameter.
- E - Internal depth.
- Ø F - Port-hole diameter.
- G - Fixing holes wheel base.
- H - Fixing holes wheel base.
- I - Fixing holes diameter.

Grounding:

External: M6 grounding point (GUB complete serie).
Internal: M5 grounding point (GUBØ → GUB 3L).
M6 grounding point (GUB 4, GUB 4A).

GUB/WE - Data Table

Dimensions [mm] and approx. Weight [Kg]

Type	Dimensions					Port-hole Ø F	Fixing			Weight
	External		Internal				G	H	Ø I	
	A	B	C	Ø D	E					
GUB/WE 0	150	240	125	102	200	79	178	125	2 x 8	3,5
GUB/WE 0H	150	280	125	102	235	79	178	125	2 x 8	5
GUB/WE 1	200	280	170	146	238	121	228	178	2 x 10	9
GUB/WE 1H	200	320	170	146	277	121	228	178	2 x 10	10,3
GUB/WE 2	250	320	225	190	277	160	275	232	4 x 10	12,5
GUB/WE 3	250	365	225	190	318	160	285	228	4 x 10	15,5
GUB/WE B3L	360	390	325	300	330	260	395	318	4 x 10	33,5
GUB/WE 3L	360	480	325	300	420	260	395	318	4 x 10	36
GUB/WE 4	450	530	410	386	440	260	485	410	4 x 10	61
GUB/WE 4A	450	460	410	386	375	260	485	410	4 x 10	56

- Note:
- dimensions can slightly differ due to casting model tolerances
 - all enclosures are available with o-ring for IP67 protection degree
 - till GUB/WE1H, the enclosures have only two fixing brackets.

GUB/WE - Drilling Table

Type	Body (holes for each side)								
	1/2"	3/4"	1"	1.1/4"	1.1/2"	2"	2.1/2"	3"	4"
GUB/WE 0	6	5	3	2	2	1	1	-	-
GUB/WE 0H	8	8	5	3	3	1	1	1	-
GUB/WE 1	8	8	5	4	3	2	1	1	-
GUB/WE 1H	8	8	5	4	4	2	1	1	-
GUB/WE 2	10	10	5	4	3	3	2	-	-
GUB/WE 3	15	15	8	6	6	3	2	2	-
GUB/WE B3L	18	17	11	8	8	5	3	2	1
GUB/WE 3L	18	17	11	8	8	5	3	2	1
GUB/WE 4	21	21	18	14	14	8	5	4	1
GUB/WE 4A	20	17	12	10	10	4	3	3	-

GUB/WE - Drilling Table

Type	1/2"	3/4"	1"	1.1/4"	1.1/2"
GUB/WE 0	2	2	1	-	-
GUB/WE 0H	2	2	1	-	-
GUB/WE 1	2	2	2	-	-
GUB/WE 1H	2	2	2	-	-
GUB/WE 2	10	2	2	-	-
GUB/WE 3	10	3	2	-	-
GUB/WE B3L	3	3	2	-	-
GUB/WE 3L	3	3	2	-	-
GUB/WE 4	3	3	3	3	3
GUB/WE 4A	3	3	3	3	3

- Note:
- available cable entry with 1/4" and 3/8" diameter (or other equivalent thread type) with the same maximum number of 1/2" holes.
 - the cable entries with Metric (x 1.5) threads are equivalent in number with the inches threads listed in the above table.
- The comparison between Metric (x 1.5) and inches is according to the following table.

GUB - Threads Comparison Table

Inches	1/4"	3/8"	1/2"	3/4"	1"	1 1/4"	1 1/2"	2"	2 1/2"	3"	4"
Metric (x 1.5)	M12	M16	M20	M25	M32	M40/M42	M50	M63	M75	M85	n.a.

Release date 2011-01-24 - Updated 2013-04-19 - A4

This datasheet does not constitute any contract obligation.

Pepperl+Fuchs reserves the right to modify the products herein illustrated without prior notice. Copyright Pepperl+Fuchs srl - Italy: +39 039 6292 1

GUB/WE - Mounting Plates

Dimensions [mm]

MODEL	Type code	A	B	C	D	E	F	Ø G	Th (1)
GUB/WE 0	-	-	-	-	-	-	-	-	-
GUB/WE 0H	-	-	-	-	-	-	-	-	-
GUB/WE 1	PPG 1	10	25	120	130	150	145	7 (2)	2
GUB/WE 1H	PPG 1	10	25	120	130	150	145	7 (2)	2
GUB/WE 2	PPG 2	15	30	150	150	185	185	7 (2)	2
GUB/WE 3	PPG 3	15	30	150	150	185	185	7 (2)	2
GUB/WE B3L	PPG 3L	20	30	110	270	290	290	7 (3)	2
GUB/WE 3L	PPG 3L	20	30	110	270	290	290	7 (3)	2
GUB/WE 4	PPG 4	20	20	140	345	360	360	7 (3)	2
GUB/WE 4A	PPG 4A	55	55	140	345	360	360	7 (3)	2

- Notes: (1): Th = Thickness [mm]
 (2): 2 fixing holes, 1 upper left side, 1 lower right side
 (3): 4 fixing holes.

GUB - Mounting Plates Drawing in galvanized steel

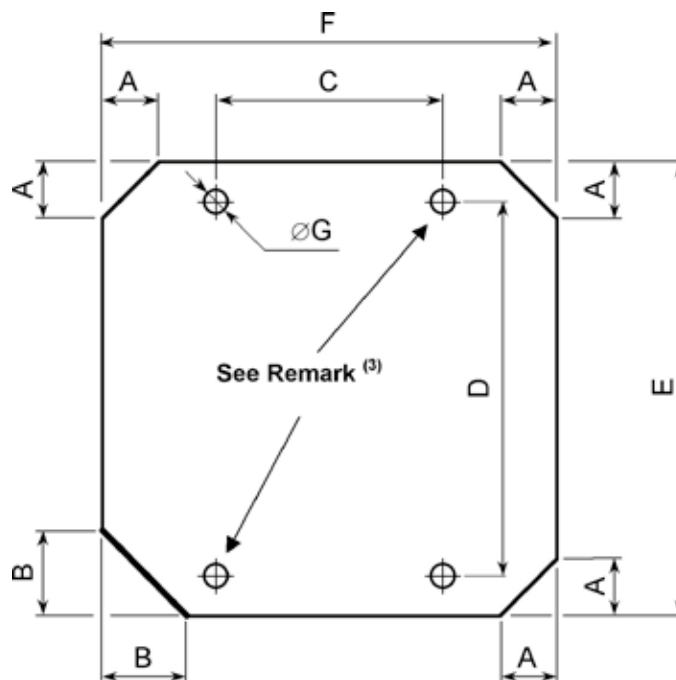

Note: the positioning of the mounting plate reported here above is purely as an example, the location of the earth screw depends on the type of enclosure.

Release date 2011-01-24 – Updated 2013-04-19 - A4



GUB/X - Stainless steel enclosure with blind cover

Description:

The GUB/X enclosures are made of stainless steel, square shaped and have a blind threaded cover.

Application:

The enclosures are suitable to contain terminals, contactors, switches, transformers, capacitors, PLC and other electric, electronic equipment and intrinsic safety devices.

Materials:

Body and cover: stainless steel AISI 316L.
Screws: stainless steel.
Welded brackets: stainless steel.

Certification characteristics:

Type of Protection: II 2GD Ex d IIC Gb / Ex tb IIIC Db
II 2GD Ex d [i. G.] IIC T6 Gb / Ex tb [i.D.] IIIC T85 °C Db.
Class of Temperature: T6/T85 °C → T3/T200 °C.
Protection Degree: IP65 / IP67*.
Certificate: INERIS 10ATEX0036.
Ambient Temperature: -50 °C / +60 °C (-20 / +40 / +50 / +55 °C).
Zones: 1 – 21 – 2 – 22.

Threads:

NPT (ANSI B1.20.1).
Metric x 1.5 (ISO 261).

On request:

AISI 304 version.
*IP67 protection with o-ring.
Galvanized or stainless steel equipment plate.
Pushbuttons, pilot light, selector switches.
Breathing / draining valve.
Wiring.
Special inhibiting treatment.
Cable glands for armoured or non armoured cable.

Drawing GUB/X

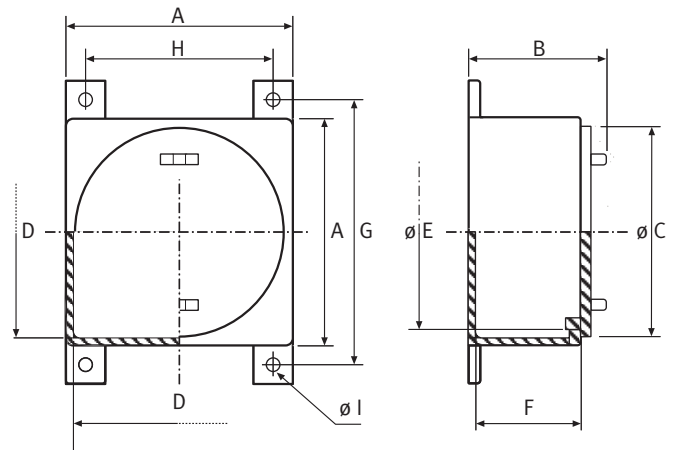

Legend:

- A - Maximum external dimension.
- B - Maximum external dimension with cover.
- Ø C - Cover external diameter.
- D - Internal dimension.
- Ø E - Body access diameter.
- F - Internal depth.
- G - Fixing holes wheel base.
- H - Fixing holes wheel base.
- Ø I - Fixing hole diameter.

Grounding:

External: M6 grounding point (GUB complete serie).
Internal: M5 grounding point (GUBØØ → GUB 3L).
M6 grounding point (GUB 4, GUB 4A).

GUB/X - Data Table

Dimensions [mm] and approx. Weight [Kg]

Type	Dimensions						Fixing			Weight
	External			Internal			G	H	Ø I	
	A	B	Ø C	D	Ø E	F				
GUB/X 00	118	134	112	92	94	98	145	95	2x8	7
GUB/X 0	150	150	136	125	114	115	178	125	2x8	12
GUB/X 0H	150	190	136	125	114	152	178	125	2x8	16
GUB/X 1	200	160	189	173	159	112	228	178	2x10	23
GUB/X 1H	200	200	189	173	159	152	228	178	2x10	27
GUB/X 1PF	176	139	170	150	147	105	196	154	2x11	23
GUB/X 2	252	185	235	225	200	116	285	228	4x10	30
GUB/X 3	258	227	235	225	200	158	285	228	4x10	37
GUB/X 3L	360	245	348	325	320	185	395	318	4x10	91
GUB/X 4A	450	249	437	410	400	160	485	410	4x14	125
GUB/X 4	450	319	437	410	400	260	485	410	4x14	150

Note: - all enclosures are available with o-ring for IP67 protection degree, - till GUB/X 1PF, the enclosures have only two fixing brackets
 - for cover handling: welded tabs are available till size GUB/X1PF and handles for the remaining sizes.

GUB/X - Drilling Table

Type	Cover	Body (holes for each side)								
	1/4"	1/2"	3/4"	1"	1.1/4"	1.1/2"	2"	2.1/2"	3"	4"
GUB/X 00	1	4	3	2	1	1	1	-	-	-
GUB/X 0	1	6	5	3	2	2	1	1	-	-
GUB/X 0H	1	8	8	5	3	3	1	1	1	-
GUB/X 1	2	8	8	5	4	3	2	1	1	-
GUB/X 1H	2	8	8	5	4	4	2	1	1	-
GUB/X 1PF	1	8	8	5	3	3	1	1	1	-
GUB/X 2	3	10	10	5	4	3	3	2	-	-
GUB/X 3	3	15	15	8	6	6	3	2	2	-
GUB/X 3L	8	18	17	11	8	8	5	3	2	1
GUB/X 4A	10	20	17	12	10	10	4	3	3	-
GUB/X 4	10	21	21	18	14	14	8	5	4	1

GUB/X - Bottom Drilling Table

Type	1/2"	3/4"	1"	1.1/4"	1.1/2"
GUB/X 00	1	1	1	-	-
GUB/X 0	2	2	1	-	-
GUB/X 0H	2	2	1	-	-
GUB/X 1	2	2	2	-	-
GUB/X 1H	2	2	2	-	-
GUB/X 1PF	2	2	1	-	-
GUB/X 2	10	2	2	-	-
GUB/X 3	10	3	2	-	-
GUB/X 3L	3	3	2	-	-
GUB/X 4A	3	3	3	3	3
GUB/X 4	3	3	3	3	3

Note: - available cable entry with 1/4" and 3/8" diameter (or other equivalent thread type) with the same maximum number of 1/2" holes.
 - the cable entries with Metric (x 1.5) threads are equivalent in number with the inches threads listed in the above table.
 The comparison between Metric (x 1.5) and inches is according to the following table.

Release date 2011-01-24 - Updated 2013-04-19 - A3

This datasheet does not constitute any contract obligation.

Pepperl+Fuchs reserves the right to modify the products herein illustrated without prior notice. Copyright Pepperl+Fuchs srl - Italy: +39 039 6292 1

GUB - Threads Comparison Table

Inches	1/4"	3/8"	1/2"	3/4"	1"	1 1/4"	1 1/2"	2"	2 1/2"	3"	4"
Metric (x 1.5)	M12	M16	M20	M25	M32	M40/M42	M50	M63	M75	M85	n.a.

GUB/X - Mounting Plates

Dimensions [mm]

MODEL	Type code	A	B	C	D	E	F	Ø G	Th (1)
GUB / X 00	-	-	-	-	-	-	-	-	-
GUB / X 0	-	-	-	-	-	-	-	-	-
GUB / X 0H	-	-	-	-	-	-	-	-	-
GUB / X 1	PPG 1	10	25	120	130	150	145	7 (2)	2
GUB / X 1H	PPG 1	10	25	120	130	150	145	7 (2)	2
GUB / X 1PF	PPG 1PF	10	25	80	105	125	125	7 (2)	2
GUB / X 2	PPG 2	15	30	150	150	185	185	7 (2)	2
GUB / X 3	PPG 3	15	30	150	150	185	185	7 (2)	2
GUB / X 3L	PPG 3L	20	30	110	270	290	290	7 (3)	2
GUB / X 4	PPG 4	20	20	140	345	360	360	7 (3)	2
GUB / X 4A	PPG 4A	55	55	140	345	360	360	7 (3)	2

- Notes: (1) - Th = Thickness [mm]
 (2) - 2 fixing holes, 1 upper left side, 1 lower right side
 (3) - 4 fixing holes.

GUB - Mounting Plates in galvanized steel

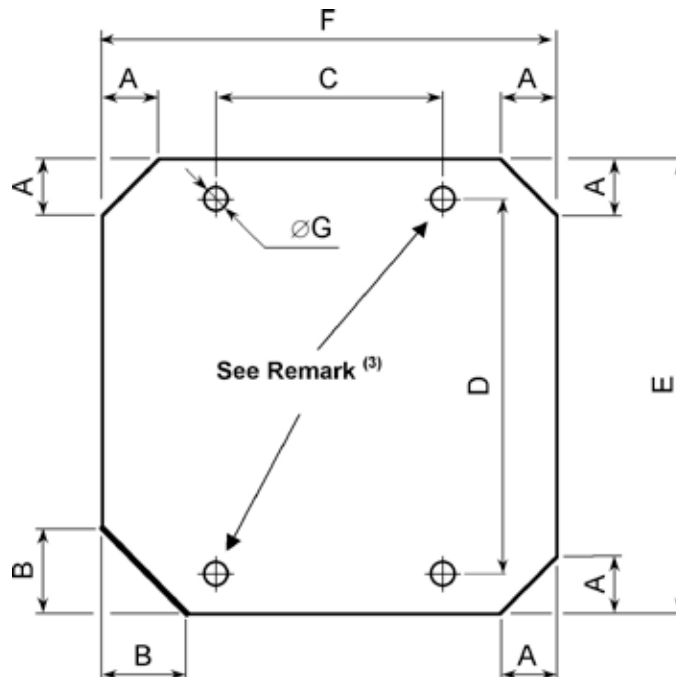

Note: the positioning of the mounting plate reported here above is purely as an example, the location of the earth screw depends on the type of enclosure.

Release date 2011-01-24 - Updated 2013-04-19 - A3



DMT 2B

Ex d IIB

Electronic earthing system

EJB application as electronic earthing system
manufactured in aluminium alloy or stainless steel

▶ P. 85



DMT 2C

Ex d IIC

Electronic earthing system

GUB application as electronic earthing system
manufactured in aluminium alloy or stainless steel

▶ P. 86

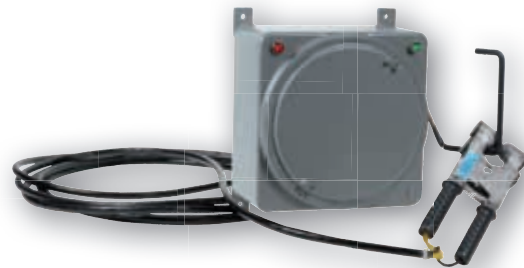

GUB/WE-TVCC

Ex d IIC

Camera housing CCTV

Enclosures for camera housing application manufactured in aluminium alloy

▶ P. 87



This datasheet does not constitute any contract obligation.

Pepperl+Fuchs reserves the right to modify the products herein illustrated without prior notice. Copyright Pepperl+Fuchs srl - Italy: +39 039 6292 1

Pepperl+Fuchs Group
www.pepperl-fuchs.com

USA: +1 330 486 0002
pa-info@us.pepperl-fuchs.com

Germany: +49 621 776 2222
pa-info@de.pepperl-fuchs.com

Singapore: +65 6779 9091
pa-info@sg.pepperl-fuchs.com

PEPPERL+FUCHS
PROTECTING YOUR PROCESS

83



DMT 2B - Electronic earthing system (Resistive and capacitive)

Description:

The DMT 2B Electronic Earthing System is composed of one IIB aluminium alloy enclosure (EJB 8A type) inside which there is an electronic resistance/capacity device and externally a support hook, an earthing clamp, complete with 8 m of cable, to measure and check the continuity towards the earth, aiming to eliminate the electrostatic charges.

The DMT 2B has (on the enclosure cover) a green and a red pilot light as agreement or refuse to proceed.

Its modularity by jumpers or trimmers placed on the electronic card, allows the selection of different capacity or resistance sensibility levels.

Application:

The DMT 2B electronic earthing system is used during filling and emptying operations of tankers, drums, railway trucks for ambient with presence of IIB gas (as. Ethylene).

Materials:

External enclosure: copper free aluminium alloy.

Screws: stainless steel.

Standard cable: 8 m 3 x 3 mm² hydrocarbon resistant.

Clamp: aluminium alloy with phosphor bronze internal contact components and handle in thermoplastic insulator material.

Certification characteristics:

Type of Protection: II 2GD Ex d [ia Ga] IIB T6 Gb
Ex tb [iaD] IIIB T85 °C Db.

Class of Temperature: T6 / T85 °C.

Protection Degree: IP66 / IP67*.

Certificate: INERIS 10ATEX0035X.

Ambient Temperature: -20 °C / +40 °C.

Zones: 1 – 21 – 2 – 22.

Threads:

NPT (ANSI B1.20.1).

Metric x 1.5 (ISO 261).

Drawing DMT 2B

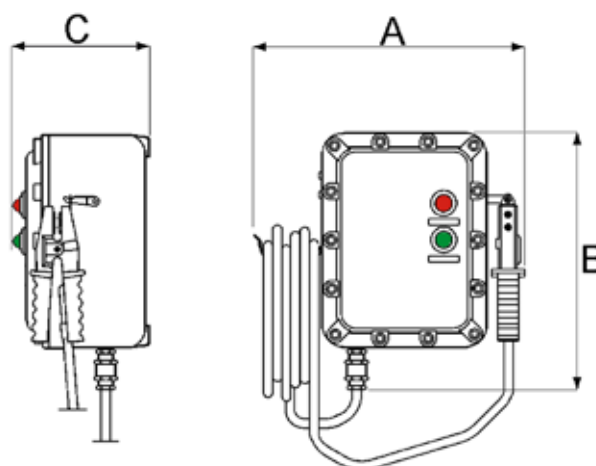

Legend:

A - Maximum external dimension.

B - Maximum external dimension.

C - Maximum external dimension.

Grounding:

External: M6 grounding point.

Internal: M5 grounding point.

Inhibiting treatments:

Standard epoxy painting RAL 7005.

On request:

Stainless steel version AISI 304 or AISI316L.

*IP67 protection with o-ring.

Stainless steel hinges.

Breathing / draining valve.

Other epoxy painting colours different from the standards.

Special inhibiting treatment.

Other type of threads [ISO7/1 (UNI6125), PG (DIN 40430)].

Cable glands for armoured or non armoured cable.

Other cable length.

Supply Voltage 110 V – 50/60 Hz.

DMT 2B - Data Table

Dimensions [mm] and approx. Weight [Kg]

Type	Dimensions			Short side	Fixing Long side	Screws	Weight
	A	B	C				
DMT 2B	470	395	215	250	282	4 x M10	20

Notes: 1) Standard rated voltage: 230 V – 50/60 Hz.

2) For complete installation and configuration options ask for specific instruction manual.

3) For enclosure dimensions see EJB data sheet (enclosure type EJB 8A).

4) Standard cable entries available: n. 2 entries Ø ¾" NPT on bottom side.

DMT 2C - Electronic earthing system (Resistive and capacitive)

Description:

The DMT 2C Electronic Earthing System is composed of one IIC aluminium alloy enclosure (GUB 3L type) inside which there is an electronic resistance/ capacity device and externally a support hook, an earthing clamp, complete with 8 m of cable, to measure and check the continuity towards the earth, aiming to eliminate the electrostatic charges.

The DMT 2C has (on the enclosure cover) a green and a red pilot light as agreement or refuse to proceed.

Its modularity by jumpers or trimmers placed on the electronic card, allow the selection of different capacity or resistance sensibility levels.

Application:

The DMT 2C electronic earthing system is used during filling and emptying operations of tankers, drums, railway trucks for ambient with presence of IIC gas (as. Hydrogen).

Materials:

External enclosure: copper free aluminium alloy.
 Screws: stainless steel.
 Standard cable: 8 m 3 x 3 mm² hydrocarbon resistant.
 Clamp: aluminium alloy with phosphor bronze internal contact components and handle in thermoplastic insulator material.

Certification characteristics:

Type of Protection: II 2GD Ex d [ia Ga] IIC T6 Gb
 Ex tb [iaD] IIIC T85 °C Db.
 Class of Temperature: T6 / T85 °C.
 Protection Degree: IP65 / IP67*.
 Certificate: INERIS 10ATEX0036.
 Ambient Temperature: -20 °C / +40 °C.
 Zones: 1 – 21 – 2 – 22.

Threads:

NPT (ANSI B1.20.1).
 Metric x 1.5 (ISO 261).

Drawing DMT 2C

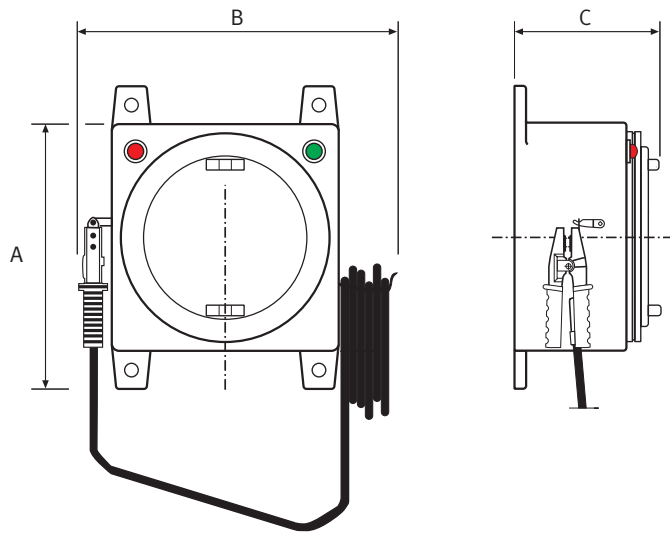

Legend:

A - Maximum external dimension.
 B - Maximum external dimension.
 C - Maximum external dimension.

Grounding:

External: M6 grounding point.
 Internal: M5 grounding point.

Inhibiting treatments:

Standard epoxy painting RAL 7005.

On request:

*IP67 protection with o-ring.
 Stainless steel version AISI 304 or AISI316L.
 Breathing / draining valve.
 Other epoxy painting colours different from the standards.
 Special inhibiting treatment.
 Other type of threads [ISO7/1 (UNI6125), PG (DIN 40430)].
 Cable glands for armoured or non armoured cable.
 Other cable length.
 Supply Voltage 110 V – 50/60 Hz.

DMT 2C - Data Table

Dimensions [mm] and approx. Weight [Kg]

Type	Dimensions			Short side	Fixing Long side	Screws	Weight
	A	B	C				
DMT 2C	360	360	245	318	395	4 x M10	25

- Notes: 1) Standard rated voltage: 230 V – 50/60 Hz.
 2) For complete installation and configuration options ask specific instruction manual.
 3) For enclosure dimensions see GUB data sheet (enclosure type GUB 3L).
 4) Standard cable entries available: n. 2 entries Ø 3/4" NPT on bottom side.

Release date 2011-01-24 – Updated 2013-04-19 - A3

This datasheet does not constitute any contract obligation.

Pepperl+Fuchs reserves the right to modify the products herein illustrated without prior notice. Copyright Pepperl+Fuchs srl - Italy: +39 039 6292 1

Description:

The camera housing GUB/WE-TVCC series is designed to contain modern compact CCTV cameras and is mounted on an internal rail allowing the regulation of the position axially. The enclosures are made of aluminium alloy, equipped with an anti-condense resistor (115/230 Vac - 50/60 Hz) and they will be delivered with an external protection roof and a support for wall mounting.

Application:

The camera housings allow the installation of the most diffused types of cameras for television at closed circuit in places where there is danger of explosion.

Materials:

Body and cover: copper free aluminium alloy.
 Port-hole: thermo-resistant tempered glass.
 Screws: stainless steel.
 Protection roof: aluminium plate.
 Articulated support: aluminium alloy.

Certification characteristics:

Type of Protection: II 2GD Ex d IIC Gb / Ex tb IIIC Db.
 Class of Temperature: T6/T85 °C → T3/T200 °C.
 Protection Degree: IP67.
 Certificate: INERIS 10ATEX0036.
 Ambient Temperature: -50 °C / +60 °C (-20 / +40 °C).
 Zones: 1 – 21 – 2 – 22.

Threads:

NPT (ANSI B1.20.1).
 Metric x 1.5 (ISO 261).

Inhibiting treatments:

Standard epoxy painting RAL 7005.
 Arm and protection roof: epoxy painting RAL 9001.

On request:

Internal camera CCTV.
 Breathing / draining valve.
 Different number / diameter / position of cable entries.
 Wiring.
 Other epoxy painting colours different by the standards.
 Special inhibiting treatment.
 Other type of threads [ISO7/1 (UNI6125), PG (DIN 40430)].
 Cable glands for armoured or non armoured cable.

Drawing GUB/WE-TVCC

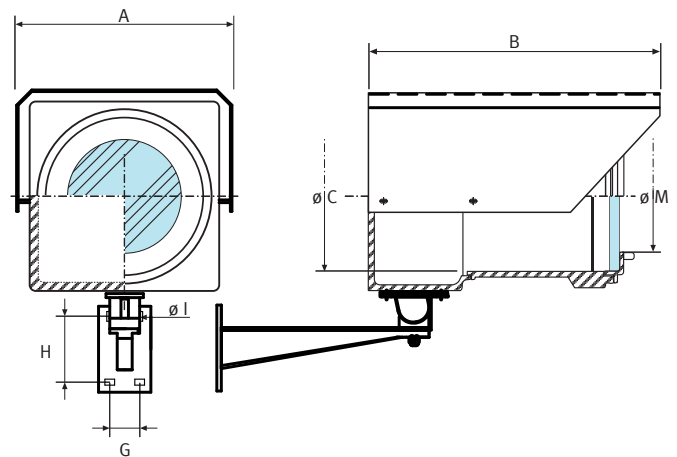

Legend:

- A - Maximum external dimension.
- B - Maximum external dimension.
- Ø C - Extension access diameter.
- G - Support fixing holes wheel base.
- H - Support fixing holes wheel base.
- Ø I - Support fixing holes diameter.
- Ø M - Port-hole diameter.

Grounding:

External: M6 grounding point.
 Internal: M5 grounding point.

GUB/WE - TVCC - Data Table

Dimensions [mm] and approx. Weight [Kg]

Type	Dimensions				Support fixing			Weight
	A	B	Ø C	Ø M	G	H	Ø I	
GUB/WE 0H - TVCC	180	300	102	79	40	85	4 x 8	5,5
GUB/WE 1H - TVCC	230	340	148	121	40	85	4 x 8	12,7
GUB/WE 3 - TVCC	280	390	192	160	40	85	4 x 8	18,5

- Note: - dimensions can slightly differ due to casting model tolerances.
 - all the GUB-TVCC are without fixing brackets.
 - standard cables entries: n. 2 with Ø ½" NPT on the bottom.
 - for enclosure dimensions see GUB/WE data sheet.

GUB/WE - TVCC Drilling Table

Type	1/2"	3/4"	1"	1.¼"	1.½"
GUB/WE 0H - TVCC	2	2	1	-	-
GUB/WE 1H - TVCC	2	2	2	-	-
GUB/WE 3 - TVCC	10	3	2	-	-

- Note: - available cable entry with 1/4" and 3/8" diameter (or other equivalent thread type) with the same maximum number of 1/2" holes.
 - the cable entraies with Metric (x 1.5) threads are equivalent in number with the inches threads listed in the above table.
 The comparison between Metric (x 1.5) and inches is according to the following table.

GUB - Threads Comparison Table

Inches	¼"	⅜"	½"	¾"	1"	1 ¼"	1 ½"	2"	2 ½"	3"	4"
Metric (x 1.5)	M12	M16	M20	M25	M32	M40/M42	M50	M63	M75	M85	n.a.

EFDC RANGE

Ex d IIB+H2

**One-row pushbutton box range**

Multifunction local control panels manufactured in aluminium alloy

▶ P. 91

This datasheet does not constitute any contract obligation.

Pepperl+Fuchs reserves the right to modify the products herein illustrated without prior notice. Copyright Pepperl+Fuchs srl - Italy: +39 039 6292 1

Pepperl+Fuchs Group
www.pepperl-fuchs.com

USA: +1 330 486 0002
pa-info@us.pepperl-fuchs.com

Germany: +49 621 776 2222
pa-info@de.pepperl-fuchs.com

Singapore: +65 6779 9091
pa-info@sg.pepperl-fuchs.com

 **PEPPERL+FUCHS**
PROTECTING YOUR PROCESS

89



EFDC - 1 row pushbutton box

Description:

The EFDC pushbutton boxes are made of aluminium alloy. They are rectangular shaped and complete with a flat joint cover, which is fixed by hexagonal head screws and two threaded holes for cable entry.

They are available in different configurations with pushbuttons, pilot lights (1" or 1/2"), switches and a potentiometer is installed.

Application:

The EFDC is designed to contain pushbuttons, pilot lights, selector switches, potentiometers combined in several configurations and as command pushbutton.

Material:

Body and cover: copper free aluminium alloy.
Screws: stainless steel.

Certification characteristics:

Type of Protection: II 2GD EEx d IIB, II 2G Ex d IIB+H₂.
Class of Temperature: T6 / T85 °C → T4 / T135 °C.
Protection Degree: IP65.
Certificate: INERIS 04ATEX0045.
Ambient Temperature: -20 / +60 °C (+40 °C).
Zones: 1 – 21 – 2 – 22.

Threads:

NPT (ANSI B1.20.1).

Inhibiting treatments:

Standard epoxy painting RAL 7005.

On request:

Pushbuttons, pilot lights, selector switches.
Other epoxy painting colours different from the standards.
Special inhibiting treatment.
Cable glands for armoured or non armoured cable.
Other type of threads [Metric x 1.5 (ISO 261), ISO7/1 (UNI6125)].

Drawing EFDC

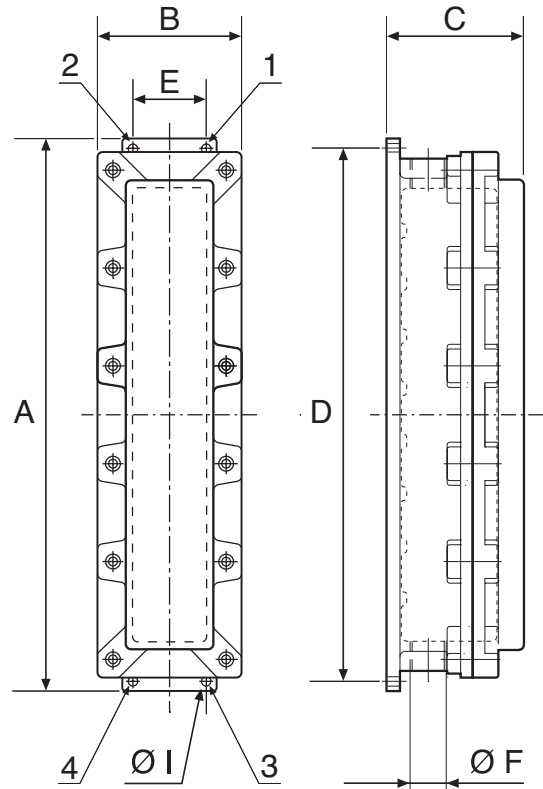

Legend:

- A - Maximum external dimension.
- B - Maximum external dimension.
- C - Maximum external dimension.
- D - Fixing holes wheel base.
- E - Fixing holes wheel base.
- Ø F - Cable entry dimension.
- Ø I - Fixing holes diameter.
- EFDC2 → EFDC6 - Ref. 2 and 3: fixing holes.
- EFDC8, EFDC11 - Ref. 1, 3 and 4: fixing holes
Ref. 2: grounding point.

Grounding:

Internal and external: M5 grounding point.

EFDC - Data Table

Dimensions [mm] and approx Weight [kg]

Type	Dimensions			Entries Ø F [NPT]	Fixation			Weight
	A	B	C		D	E	Ø I	
EFDC 2	143	113	87	2x3/4"	125	55	2x7	1.45
EFDC 3	196	115	90	2x3/4"	172	93	2x7	1.9
EFDC 4	239	108	103	2x3/4"	227	48	2x7	2.65
EFDC 6	336	108	103	2x3/4"	340	40	2x7	3.4
EFDC 8	412	108	103	2x1"	400	44	4x7	4.3
EFDC 11	525	108	103	2x1"	510	44	4x7	11.4

- Note: 1) Maximum lamp voltage and power: 240 V – 5 W.
2) For IIB+H₂ version, letter “-H” to be added after “EFDC” (e.g. EFDC-H).
3) Pushbutton suffix identifies the max. number of 1/2" components (pushbutton and pilot light); other components (potentiometer, switches, ...) may require more than one place.
4) Dimensions can slightly differ due to casting model tolerance.

Release date 2011-08-03 – Updated 2012-11-20 - A2



This datasheet does not constitute any contract obligation.

Pepperl+Fuchs reserves the right to modify the products herein illustrated without prior notice. Copyright Pepperl+Fuchs srl - Italy: +39 039 6292 1

EFD21 RANGE

Ex d IIC



Local control range
Single rotary switch control units

▶ P. 95

EFD21-LP RANGE

Ex d IIC



Local control range
Single or double pushbuttons and/or pilot lights control units

▶ P. 96

EFD21-F RANGE

Ex d IIC



Local control range
Single mushroom pushbutton control units

▶ P. 97

EFD21-VR RANGE

Ex d IIC



Local control range
Emergency mushroom pushbutton control units with breaking glass

▶ P. 98

This datasheet does not constitute any contract obligation.

Pepperl+Fuchs reserves the right to modify the products herein illustrated without prior notice. Copyright Pepperl+Fuchs srl - Italy: +39 039 6292 1

Pepperl+Fuchs Group
www.pepperl-fuchs.com

USA: +1 330 486 0002
pa-info@us.pepperl-fuchs.com

Germany: +49 621 776 2222
pa-info@de.pepperl-fuchs.com

Singapore: +65 6779 9091
pa-info@sg.pepperl-fuchs.com

PEPPERL+FUCHS
PROTECTING YOUR PROCESS



This datasheet does not constitute any contract obligation.

Pepperl+Fuchs reserves the right to modify the products herein illustrated without prior notice. Copyright Pepperl+Fuchs srl - Italy: +39 039 6292 1

EFD21 - Switch/Selector switch box

Description:

The EFD21 enclosure is made of aluminium alloy. It has a rectangular base and a cylindrical joint cover and is equipped with a switch, a selector switch or a deviator switch. It is usually supplied with an engraved circular label and an electrical part (rear cover type) too.

Application:

The EFD21 switch is designed for the control and signalling for electrical circuits. Its mounting is very easy thanks to the small dimensions.

Material:

Body and cover: copper free aluminium alloy.
Screws: stainless steel.
External handle: plastic material.

Features:

Type of Protection: II 2GD EEx d IIC.
Class of Temperature: T6 / T85 °C, T5 / T100 °C.
Protection Degree: IP65 / IP67*.
Certificate: INERIS 05ATEX0030.
Ambient Temp.: -20 / +60 °C (+40 °C).
Zones: 1 – 21 – 2 – 22.

Threads:

NPT (ANSI B1.20.1).

Inhibiting treatments:

Standard epoxy painting RAL 7005.

Drawing EFD21

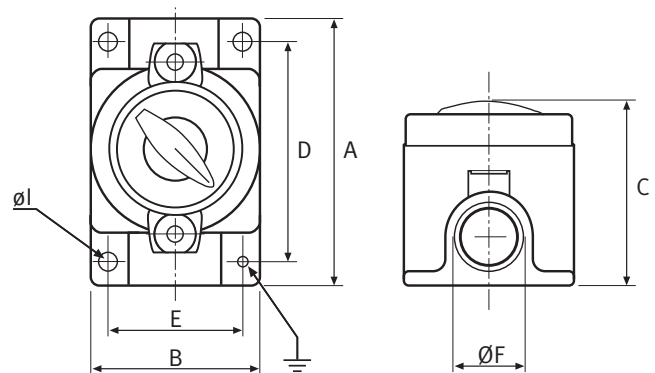

Legend:

- A - Maximum external dimension.
- B - Maximum external dimension.
- C - Maximum external dimension with external handle.
- D - Fixing holes wheel base.
- E - Fixing holes wheel base.
- Ø F - Cable entry diameter.
- Ø I - Fixing holes diameter.

Grounding:

External: M6 grounding point.
Internal: M5 grounding point.

On request:

- *IP67 protection with o-ring.
- Special contacts diagram.
- Special selector with spring return.
- External metallic handle.
- Padlockable version.
- External protection guard.
- Different configuration of electric contacts.
- Other epoxy painting colours different from the standards.
- Special inhibiting treatment.
- Other type of threads [ISO7/1 (UNI6125), Metric x 1.5 (ISO 261)].
- Cable glands for armoured or non armoured cable.

EFD21 - Data Table

Dimensions [mm] and approx. Weight [kg]

Type	Description	Poles	Dimensions			Entries	Fixation			Weight
			A	B	C	Ø F [NPT]	D	E	Ø I	
EFD21/R 216	Switch "0 - 1"	2	125	80	115	2 x 3/4"	102	58	3 x 6	1
EFD21/R 316	Switch "0 - 1"	3	125	80	115	2 x 3/4"	102	58	3 x 6	1
EFD21/R 416	Switch "0 - 1"	4	125	80	115	2 x 3/4"	102	58	3 x 6	1
EFD21/C 116	Selector switch "1 - 0 - 2"	1	125	80	115	2 x 3/4"	102	58	3 x 6	1
EFD21/C 216	Selector switch "1 - 0 - 2"	2	125	80	115	2 x 3/4"	102	58	3 x 6	1
EFD21/D 116	Selector switch "1 - 2"	1	125	80	115	2 x 3/4"	102	58	3 x 6	1
EFD21/D 216	Selector switch "1 - 2"	2	125	80	115	2 x 3/4"	102	58	3 x 6	1

Note: Maximum rated current: 16 A.

Release date 2011-08-03 - Updated 2013-04-19 - A2

EFD21-LP - Pushbutton box with 1 or 2 components

Description:

The EFD21-LP enclosure is made of aluminium alloy, it has a rectangular base and a cylindrical joint cover. It is available in different configurations with either one 1" component installed, or a pushbutton or a pilot light, or with two ½" components installed, being 2 pushbuttons, 2 pilot lights or 1 pushbutton and 1 pilot light.

Mounting is easy thanks to the small dimensions.

Application:

The EFD21-LP pushbutton is designed for the control and signalling for electrical circuits.

Material:

Body and cover: copper free aluminium alloy.

Screws: stainless steel.

Certification characteristics:

Type of Protection: II 2GD EEx d IIC.

Class of Temperature: T6 / T85 °C, T5 / T100 °C.

Protection Degree: IP65 / IP67*.

Certificate: INERIS 05ATEX0030.

Ambient Temperature: -20 / +60 °C (+40 °C).

Zones: 1 – 21 – 2 – 22.

Threads:

NPT (ANSI B1.20.1).

Inhibiting treatments:

Standard epoxy painting RAL 7005.

Drawing EFD21-LP

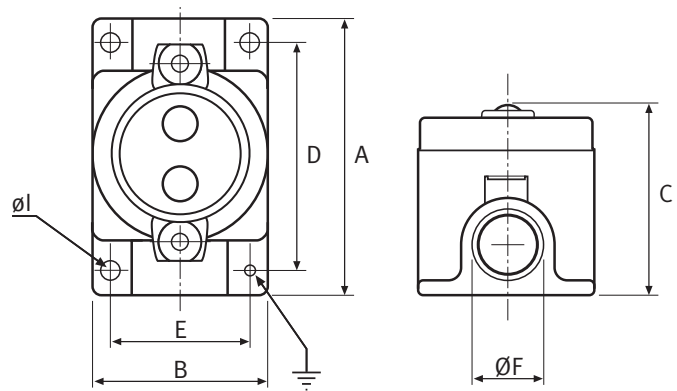

Legend:

A - Maximum external dimension.

B - Maximum external dimension.

C - Maximum external dimension.

D - Fixing holes wheelbase.

E - Fixing holes wheelbase.

Ø F - Cable entry diameter.

Ø I - Fixing holes diameter.

Grounding:

External: M6 grounding point.

Internal: M5 grounding point.

On request:

*IP67 only with pilot lights.

Lamp or led with different voltage.

Different configuration and colours of pushbuttons and pilot lights.

Other epoxy painting colours different from the standards.

Special inhibiting treatment.

Other type of threads [ISO7/1 (UNI6125), Metric x 1.5 (ISO 261)].

Cable glands for armoured or non armoured cable.

EFD21-LP - Data Table

Dimensions [mm] and approx. Weight [kg]

Type	Description	Contact	Lampholder	Dimensions			Entries Ø F [NPT]	Fixation			Weight
				A	B	C		D	E	Ø I	
EFD21/2L	n. 2 Pilot lights ½"	-	Ba9s	125	80	115	2 x 3/4"	102	58	3x6	1,1
EFD21/1L-1P	P. light ½" + P. button ½"	N.O or N.C.	Ba9s	125	80	115	2 x 3/4"	102	58	3x6	1,1
EFD21/2P	n. 2 Pushbuttons	N.O and/or N.C.	-	125	80	115	2 x 3/4"	102	58	3x6	1,1
EFD21/1P	n. 1 Pushbutton 1"	N.O and/or N.C.	-	125	80	115	2 x 3/4"	102	58	3x6	1,1
EFD21/1L	n. 1 Pilot light 1"	-	E14	125	80	115	2 x 3/4"	102	58	3x6	1,1

Note: 1) Maximum lamp voltage and power: 240 V – 3 W.

2) Rated current and voltage: 6 A – 240 Vac or 10A – 24 Vac.

3) With 1" pushbutton (RP1) - Max. n. 2+2 contacts installed in parallel;
with ½" pushbutton (RP2) - Max. n. 2 contacts in series.

Release date 2011-08-03 – Updated 2013-04-19 - A2

This datasheet does not constitute any contract obligation.

Pepperl+Fuchs reserves the right to modify the products herein illustrated without prior notice. Copyright Pepperl+Fuchs srl - Italy: +39 039 6292 1

EFD21-F - Emergency mushroom pushbutton box

Description:

The EFD21-F enclosure is made of aluminium alloy. It has a rectangular base and a cylindrical joint cover and is equipped with a red emergency mushroom pushbutton (RPFB) with pushing lock function and twist reset, circular label with yellow background and is usually supplied with electric contact.

Application:

The EFD21-F Emergency Mushroom Pushbutton is designed for the emergency shutdown of electric circuits.

Material:

Body and cover: copper free aluminium alloy.
Screws: stainless steel.
External ring nut: nickel plated brass.
Actuator: plastic material.

Certification characteristics:

Type of Protection: II 2GD EEx d IIC.
Class of Temperature: T6 / T85 °C, T5 / T100 °C.
Protection Degree: IP65.
Certificate: INERIS 05ATEX0030.
Ambient Temp.: -20 / +60 °C (+40 °C).
Zones: 1 – 21 – 2 – 22.

Threads:

NPT (ANSI B1.20.1).

Inhibiting treatments:

Standard epoxy painting RAL 7005.

Drawing EFD21-F

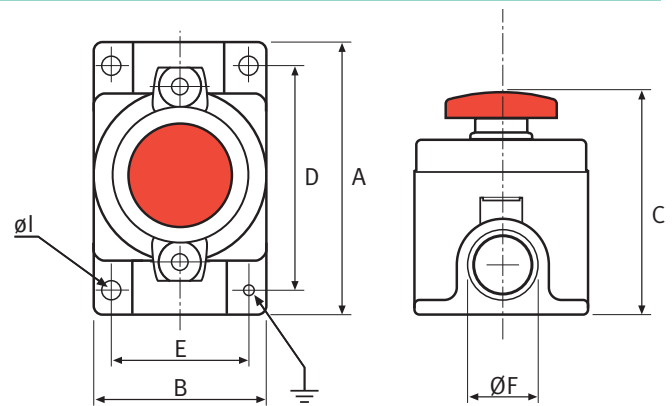

Legend:

A - Maximum external dimension.
B - Maximum external dimension.
C - Maximum external dimension.
D - Fixing holes wheelbase.
E - Fixing holes wheelbase.
Ø F - Cable entry diameter.
Ø I - Fixing holes diameter.

Grounding:

External: M6 grounding point.
Internal: M5 grounding point.

On request:

Different configuration of electric contacts.
Key mushroom pushbutton (red or black).
Mushroom pushbutton without lock function.
Other epoxy painting colours different from the standards.
Special inhibiting treatment.
Other texts of labels (as "STOP – EMERGENCY").
External protection guard.
Other type of threads [ISO7/1 (UNI6125), Metric x1.5 (ISO 261)].
Cable glands for armoured or non armoured cable.

EFD21-F - Data Table

Dimensions [mm] and approx. Weight [kg]

Type	Description	Contact	Dimensions			Entries Ø F [NPT]	Fixation			Weight
			A	B	C		D	E	Ø I	
EFD21-FB.01	Emergency Mushroom Pushbutton with mechanical block	1NC	125	80	155	2 x 3/4"	102	58	3x6	1,7
EFD21-FB.10	Emergency Mushroom Pushbutton with mechanical block	1NO	125	80	155	2 x 3/4"	102	58	3x6	1,7
EFD21-FB.11	Emergency Mushroom Pushbutton with mechanical block	1NO+1NC	125	80	155	2 x 3/4"	102	58	3x6	1,7
EFD21-FBCH.01	Emergency Mushroom Pushbutton with Key & mechanical block	1NC	125	80	155	2 x 3/4"	102	58	3x6	1,7
EFD21-FBCH.10	Emergency Mushroom Pushbutton with Key & mechanical block	1NO	125	80	155	2 x 3/4"	102	58	3x6	1,7
EFD21-FBCH.11	Emergency Mushroom Pushbutton with Key & mechanical block	1NO+1NC	125	80	155	2 x 3/4"	102	58	3x6	1,7

Note: 1) RPFB rated current and voltage: 6 A – 240 Vac or 10 A – 24 Vac.
2) EFD21-F: Max. n. 2+2 contacts installed in parallel.
3) _CH = with key; _B = with block (see table above).

Release date 2010-08-03 – Updated 2012-11-20 - A2

This datasheet does not constitute any contract obligation.

Pepperl+Fuchs reserves the right to modify the products herein illustrated without prior notice. Copyright Pepperl+Fuchs srl - Italy: +39 039 6292 1

Pepperl+Fuchs Group
www.pepperl-fuchs.com

USA: +1 330 486 0002
pa-info@us.pepperl-fuchs.com

Germany: +49 621 776 2222
pa-info@de.pepperl-fuchs.com

Singapore: +65 6779 9091
pa-info@sg.pepperl-fuchs.com

PEPPERL+FUCHS
PROTECTING YOUR PROCESS

97

EFD21-VR - Emergency mushroom pushbutton box with breaking glass

Description:

The EFD21-VR enclosure is made of aluminium alloy. It has a rectangular base and a cylindrical joint cover with breaking glass in case of emergency. The product comes complete with ½" red push button, circular label with red background, electric contact, a hammer and a chain.

Application:

The EFD21-VR emergency mushroom pushbutton with breaking glass is designed for special application in the emergency shutdown of electric circuits.

Material:

Body and cover: copper free aluminium alloy.
Screws: stainless steel.
Glass: tempered glass.

Certification characteristics:

Type of Protection: II 2GD EEx d IIC.
Class of Temperature: T6 / T85 °C, T5 / T100 °C.
Protection Degree: IP65.
Certificate: INERIS 05ATEX0030.
Ambient Temp.: -20 / +60 °C (+40 °C).
Zones: 1 – 21 – 2 – 22.

Threads:

NPT (ANSI B1.20.1).

Inhibiting treatments:

Standard epoxy painting RAL 7005.
Red ring-cover (RAL3000).

Drawing EFD21-VR

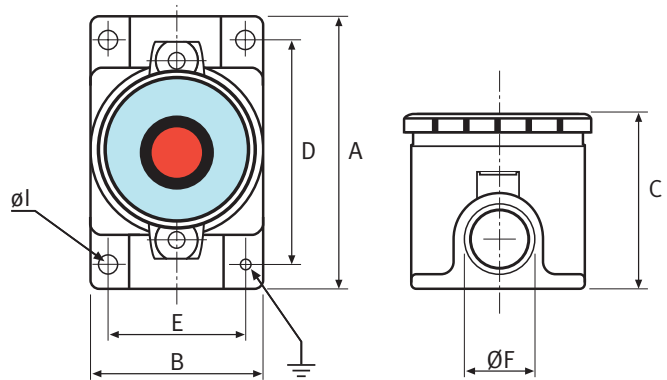

Legend:

A - Maximum external dimension.
B - Maximum external dimension.
C - Maximum external dimension.
D - Fixing holes wheelbase.
E - Fixing holes wheelbase.
Ø F - Cable entry diameter.
Ø I - Fixing holes diameter.

Grounding:

External: M6 grounding point.
Internal: M5 grounding point.

On request:

“Pressing” type function or “release” type function.
Other epoxy painting colours different from the standards.
Special inhibiting treatment.
Other type of threads [ISO7/1 (UNI6125), Metric x 1.5 (ISO 261)].
Cable glands for armoured or non armoured cable.

EFD21-VR - Data Table

Dimensions [mm] and approx. Weight [kg]

Type	Contact	Dimensions			Entries Ø F [NPT]	Fixation			Weight
		A	B	C		D	E	Ø I	
EFD21-VR.01	1 NC	125	80	117	2 x 3/4"	102	58	3 x 6	1,25
EFD21-VR.02	2 NC	125	80	117	2 x 3/4"	102	58	3 x 6	1,25
EFD21-VR.11	1NO + 1NC	125	80	117	2 x 3/4"	102	58	3 x 6	1,25
EFD21-VR.10	1 NO	125	80	117	2 x 3/4"	102	58	3 x 6	1,25
EFD21-VR.20	2 NO	125	80	117	2 x 3/4"	102	58	3 x 6	1,25

Note: EFD21-VR rated current and voltage: 6 A – 240 Vac or 10 A – 24 Vac.

Release date 2011-08-03 – Updated 2012-11-20 - A2





E110 RANGE

Ex d IIC



Local control range - Ex d IIC

20A Single rotary switch control units manufactured in cast iron

▶ P. 105

E112 RANGE

Ex d IIC



Local control range - Ex d IIC

Local fuse units manufactured in cast iron

▶ P. 106

E114 RANGE

Ex d IIC



Local control range - Ex d IIC

Single and twin indicator lights manufactured in cast iron

▶ P. 107

E116 RANGE

Ex d IIC



Local control range - Ex d IIC

Single and double pushbuttons manufactured in cast iron

▶ P. 108

E116010 RANGE

Ex d IIC



Local control range - Ex d IIC

Single emergency mushroom pushbuttons manufactured in cast iron

▶ P. 109

E118 RANGE

Ex d IIC



Local control range - Ex d IIC

Photocell units manufactured in cast iron

▶ P. 110

This datasheet does not constitute any contract obligation.

Pepperl+Fuchs reserves the right to modify the products herein illustrated without prior notice. Copyright Pepperl+Fuchs srl - Italy: +39 039 6292 1

Pepperl+Fuchs Group
www.pepperl-fuchs.comUSA: +1 330 486 0002
pa-info@us.pepperl-fuchs.comGermany: +49 621 776 2222
pa-info@de.pepperl-fuchs.comSingapore: +65 6779 9091
pa-info@sg.pepperl-fuchs.com



E110 - Ex d IIC 20A General Purpose Switch

Description:

The E110*/CI series of flameproof general purpose switches is made of cast iron. It features a shrouded padlockable operator unit and is available as OFF-ON and changeover switch in various configurations.

Application:

The E110* switches are designed for control of electrical circuits in explosion hazardous areas.

Material:

Body: cast iron.
Screws: stainless steel.
Plastic Parts: nylon.

Certification characteristics:

Type of Protection: II 2 GD Ex d IIC / Ex tb IIIC.
Class of Temperature: T6 / T80 °C, T5 / T95 °C.
Protection Degree: IP65.
Certificate: SIRA 02 ATEX 1307.
Further certifications see below.
Ambient Temperature: -40 ... 55 °C (-40 ... 131 °F).
Zones: 1 – 21 – 2 – 22.

Threads:

Metric threaded M20 at entry face A and B.

Inhibiting treatments:

Zinc rich epoxy powder primer plus epoxy powder top coat black.

Drawing:

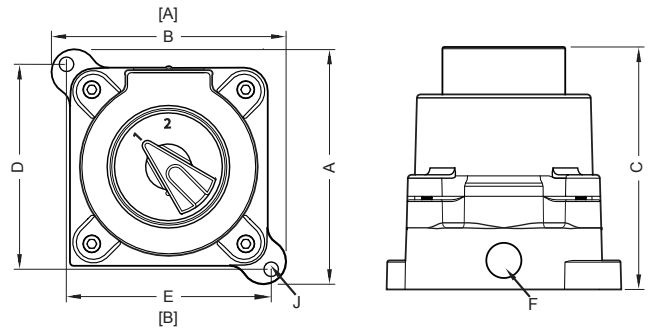

Legend:

- A - Maximum external dimension.
- B - Maximum external dimension.
- C - Maximum external dimension.
- D - Fixing holes wheelbase.
- E - Fixing holes wheelbase.
- Ø F - Cable entry diameter.
- Ø J - Fixing holes diameter.
- [A] - Entry face.
- [B] - Entry face.

E110 - Data Table

Dimensions [mm] and approx. Weight [kg]

Type	Description	Poles	Dimensions			Entries Ø F	Fixation			Weight
			A	B	C		D	E	Ø J	
E110002	Changeover switch "1 – 2"	2	134	134	138	2x M20	117	117	8.3	5.1
E110003	Changeover switch "1 – OFF – 2"	2	134	134	138	2x M20	117	117	8.3	5.1
E110006	Switch "OFF – ON"	4	134	134	138	2x M20	117	117	8.3	5.1

For further information see individual data sheets on www.pepperl-fuchs.com

International approvals

IECEx approval	IECEx SIR 08.0058
GOST-R approval	GOST-R B00997

This datasheet does not constitute any contract obligation.

Pepperl+Fuchs reserves the right to modify the products herein illustrated without prior notice. Copyright Pepperl+Fuchs srl - Italy: +39 039 6292 1

Pepperl+Fuchs Group USA: +1 330 486 0002 Germany: +49 621 776 2222 Singapore: +65 6779 9091
www.pepperl-fuchs.com pa-info@us.pepperl-fuchs.com pa-info@de.pepperl-fuchs.com pa-info@sg.pepperl-fuchs.com

E112 - Ex d IIC Fuse Unit

Description:

The E112*/CI series of flameproof local fuse units is made of cast iron. It is available with several fuse ratings and configurations.

Fuse type: BS88 industrial pullcap.

Application:

The E112* fuse units are designed for overload protection of electrical circuits in explosion hazardous areas.

Material:

Body: cast iron.
Screws: stainless steel.

Certification characteristics:

Type of Protection: II 2 GD Ex d IIC / Ex tb IIIC.
Class of Temperature: T6 / T80 °C, T5 / T95 °C.
Protection Degree: IP65.
Certificate: SIRA 02 ATEX 1308.
Further certifications see below.
Ambient Temperature: -40 ... 55 °C (-40 ... 131 °F).
Zones: 1 – 21 – 2 – 22.

Threads:

Metric threaded M20 at entry face A and B.

Inhibiting treatments:

Zinc rich epoxy powder primer plus epoxy powder top coat black.

Drawing:

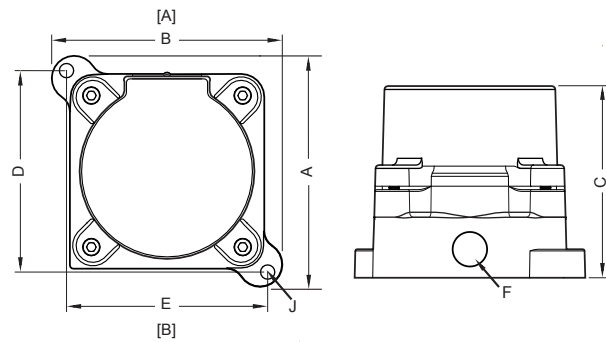

Legend:

- A - Maximum external dimension.
- B - Maximum external dimension.
- C - Maximum external dimension.
- D - Fixing holes wheelbase.
- E - Fixing holes wheelbase.
- Ø F - Cable entry diameter.
- Ø J - Fixing holes diameter.
- [A] - Entry face.
- [B] - Entry face.

E112 - Data Table

Dimensions [mm] and approx. Weight [kg]

Type	Fuse configuration	Fuse rating	Dimensions			Entries Ø F	Fixation			Weight
			A	B	C		D	E	Ø J	
E112001	Single pole and neutral	6A	134	134	111	2x M20	117	117	8.3	5.1
E112002	Double pole	6A	134	134	111	2x M20	117	117	8.3	5.1
E112011	Single pole and neutral	10A	134	134	111	2x M20	117	117	8.3	5.1
E112012	Double pole	10A	134	134	111	2x M20	117	117	8.3	5.1
E112021	Single pole and neutral	16A	134	134	111	2x M20	117	117	8.3	5.1
E112022	Double pole	16A	134	134	111	2x M20	117	117	8.3	5.1

For further information see individual data sheets on www.pepperl-fuchs.com

International approvals

IECEX approval	IECEX SIR 08.0059
GOST-R approval	GOST-R B00997

This datasheet does not constitute any contract obligation.

Pepperl+Fuchs reserves the right to modify the products herein illustrated without prior notice. Copyright Pepperl+Fuchs srl - Italy: +39 039 6292 1

E114 - Ex d IIC Single and Twin Indicator Lights

Description:

The E114*/CI series of flameproof indicator lights is made of cast iron. Variants with either one or two LEDs are available, each with various lens colors.

Application:

The E114* indicator lights are designed for equipment monitoring and optical signaling in explosion hazardous areas.

Material:

Body: cast iron.
Screws: stainless steel.

Drawing:

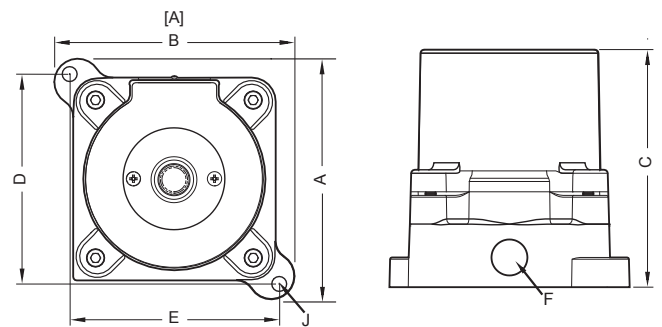

Certification characteristics:

Type of Protection: II 2 GD Ex d IIC / Ex tb IIIC.
Class of Temperature: T6 / T80 °C, T5 / T95 °C.
Protection Degree: IP65.
Certificate: SIRA 02 ATEX 1310.
Further certifications see below.
Ambient Temperature: -40 ... 55 °C (-40 ... 131 °F).
Zones: 1 – 21 – 2 – 22.

Legend:

A - Maximum external dimension.
B - Maximum external dimension.
C - Maximum external dimension.
D - Fixing holes wheelbase.
E - Fixing holes wheelbase.
Ø F - Cable entry diameter.
Ø J - Fixing holes diameter.
[A] - Entry face.
[B] - Entry face.

Threads:

Metric threaded M20 at entry face A and B.

Inhibiting treatments:

Zinc rich epoxy powder primer plus epoxy powder top coat black.

E114 - Data Table

Dimensions [mm] and approx. Weight [kg]

Type	Number of LED	Lens color	Dimensions			Entries Ø F	Fixation			Weight
			A	B	C		D	E	Ø J	
E114001	1	Green	134	134	133	2x M20	117	117	8.3	5.1
E114002	1	Red	134	134	133	2x M20	117	117	8.3	5.1
E114003	1	Amber	134	134	133	2x M20	117	117	8.3	5.1
E114004	1	White	134	134	133	2x M20	117	117	8.3	5.1
E114005	2	Green / red	134	134	133	2x M20	117	117	8.3	5.1
E114006	2	Green / amber	134	134	133	2x M20	117	117	8.3	5.1
E114007	2	Green / white	134	134	133	2x M20	117	117	8.3	5.1
E114008	2	Red / amber	134	134	133	2x M20	117	117	8.3	5.1
E114009	2	Red / white	134	134	133	2x M20	117	117	8.3	5.1
E114010	2	Amber / white	134	134	133	2x M20	117	117	8.3	5.1

For further information see individual data sheets on www.pepperl-fuchs.com

International approvals

IECEX approval
GOST-R approval

IECEX SIR 08.0061
GOST-R B00997

This datasheet does not constitute any contract obligation.

Pepperl+Fuchs reserves the right to modify the products herein illustrated without prior notice. Copyright Pepperl+Fuchs srl - Italy: +39 039 6292 1

Pepperl+Fuchs Group
www.pepperl-fuchs.com

USA: +1 330 486 0002
pa-info@us.pepperl-fuchs.com

Germany: +49 621 776 2222
pa-info@de.pepperl-fuchs.com

Singapore: +65 6779 9091
pa-info@sg.pepperl-fuchs.com

PEPPERL+FUCHS
PROTECTING YOUR PROCESS

E116 - Ex d IIC Single and Double Pushbuttons

Description:

The E116*/CI series of flameproof pushbutton units is made of cast iron. Variants with either one or two pushbuttons are available, each in various colors. Pushbuttons come in various designs, shrouded or exposed, as well as with latching options.

Application:

The E116* pushbuttons are designed for control of instrumentation and electrical circuits in explosion hazardous areas.

Material:

Body: cast iron.
Screws: stainless steel.
Plastic parts: nylon.

Certification characteristics:

Type of Protection: II 2 GD Ex d IIC / Ex tb IIIC.
Class of Temperature: T6 / T80 °C, T5 / T95 °C.
Protection Degree: IP65.
Certificate: SIRA 02 ATEX 1312.
Further certifications see below.
Ambient Temperature: -40 ... 55 °C (-40 ... 131 °F).
Zones: 1 – 21 – 2 – 22.

Threads:

Metric threaded M20 at entry face A and B.

Inhibiting treatments:

Zinc rich epoxy powder primer plus epoxy powder top coat black.

Drawing:

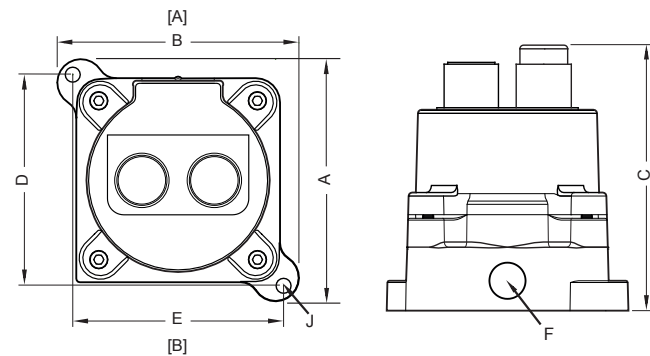

Legend:

- A - Maximum external dimension.
- B - Maximum external dimension.
- C - Maximum external dimension.
- D - Fixing holes wheelbase.
- E - Fixing holes wheelbase.
- Ø F - Cable entry diameter.
- Ø J - Fixing holes diameter.
- [A] - Entry face.
- [B] - Entry face.

E116 - Data Table

Dimensions [mm] and approx. Weight [kg]

Type	Pushbuttons	Labeling	Dimensions			Entries Ø F	Fixation			Weight
			A	B	C		D	E	Ø J	
E116001	Green shrouded	START	134	134	136	2x M20	117	117	8.3	5.1
E116002	Red shrouded	STOP	134	134	136	2x M20	117	117	8.3	5.1
E116003	Red exposed	STOP	134	134	146	2x M20	117	117	8.3	5.1
E116005	Green shrouded/Red shrouded	START/STOP	134	134	136	2x M20	117	117	8.3	5.1
E116006	Green shrouded/Red exposed	START/STOP	134	134	146	2x M20	117	117	8.3	5.1

For further information see individual data sheets on www.pepperl-fuchs.com

International approvals

IECEx approval
GOST-R approval

IECEx SIR 08.0063
GOST-R B00997

E116010 - Ex d IIC Single Emergency Stop Pushbutton

Description:

The E116010/CI series of flameproof emergency stop pushbutton units is made of cast iron. The red mushroom pushbutton is latching with lever release. The contact configuration is 1 NO and 1 NC.

Application:

The E116010 pushbutton units are designed for emergency stops of machinery and instrumentation in explosion hazardous areas.

Material:

Body: cast iron.
Screws: stainless steel.
Plastic Parts: nylon.

Certification characteristics:

Type of Protection: II 2 GD Ex d IIC / Ex tb IIIC.
Class of Temperature: T6 / T80 °C, T5 / T95 °C.
Protection Degree: IP65.
Certificate: SIRA 02 ATEX 1312.
Further certifications see below.
Ambient Temperature: -40 ... 55 °C (-40 ... 131 °F).
Zones: 1 – 21 – 2 – 22.

Threads:

Metric threaded M20 at entry face A and B.

Inhibiting treatments:

Zinc rich epoxy powder primer plus epoxy powder top coat black.

Drawing:

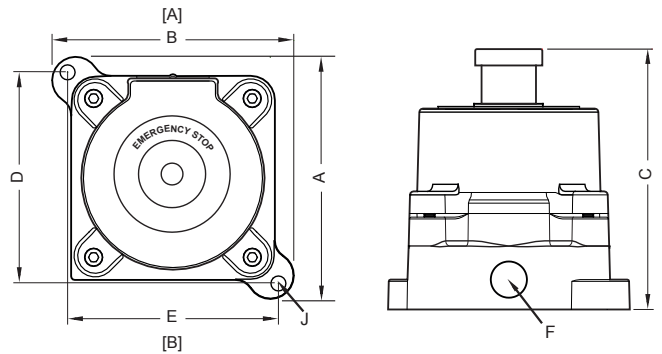

Legend:

- A - Maximum external dimension.
- B - Maximum external dimension.
- C - Maximum external dimension.
- D - Fixing holes wheelbase.
- E - Fixing holes wheelbase.
- Ø F - Cable entry diameter.
- Ø J - Fixing holes diameter.
- [A] - Entry face.
- [B] - Entry face.

E116010 - Data Table

Dimensions [mm] and approx. Weight [kg]

Type	Pushbuttons	Labeling	Dimensions			Entries	Fixation			Weight
			A	B	C	Ø F	D	E	Ø J	
E116010	Red mushroom latching	EMERGENCY STOP	134	134	144	2x M20	117	117	8.3	5.1

For further information see individual data sheets on www.pepperl-fuchs.com

International approvals

IECEx approval	IECEx SIR 08.0063
GOST-R approval	GOST-R B00997

This datasheet does not constitute any contract obligation.

Pepperl+Fuchs reserves the right to modify the products herein illustrated without prior notice. Copyright Pepperl+Fuchs srl - Italy: +39 039 6292 1

Pepperl+Fuchs Group
www.pepperl-fuchs.com

USA: +1 330 486 0002
pa-info@us.pepperl-fuchs.com

Germany: +49 621 776 2222
pa-info@de.pepperl-fuchs.com

Singapore: +65 6779 9091
pa-info@sg.pepperl-fuchs.com

FP PEPPERL+FUCHS
PROTECTING YOUR PROCESS

107

Description:

The E118*/CI series of flameproof photocell units is made of cast iron. It switches ON at 70 Lux and OFF at 35 Lux, the switching load is 3 x 400 W max. inductive.

Application:

The E118 pushbutton units are designed for switching electrical circuits according to ambient illumination in explosion hazardous areas.

Material:

Body: cast iron.
Screws: stainless steel.
Glass: toughened glass.

Certification characteristics:

Type of Protection: II 2 GD Ex d IIC / Ex tb IIIC.
Class of Temperature: T6 / T80 °C, T5 / T95 °C.
Protection Degree: IP65.
Certificate: SIRA 02 ATEX 1314.
Further certifications see below.
Ambient Temperature: -40 ... 55 °C (-40 ... 131 °F).
Zones: 1 – 21 – 2 – 22.

Threads:

Metric threaded M20 at entry face A and B.

Inhibiting treatments:

Zinc rich epoxy powder primer plus epoxy powder top coat black.

Drawing:

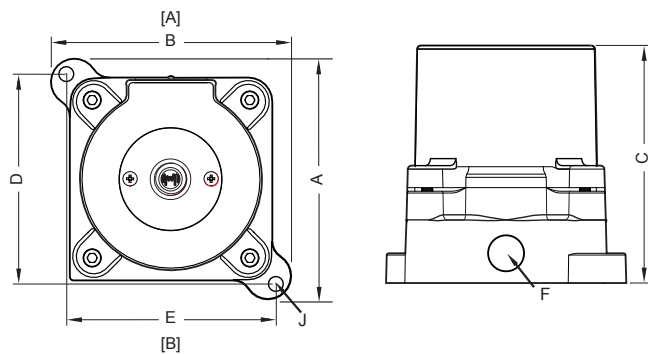

Legend:

- A - Maximum external dimension.
- B - Maximum external dimension.
- C - Maximum external dimension.
- D - Fixing holes wheelbase.
- E - Fixing holes wheelbase.
- Ø F - Cable entry diameter.
- Ø J - Fixing holes diameter.
- [A] - Entry face.
- [B] - Entry face.

E118 - Data Table

Dimensions [mm] and approx. Weight [kg]

Type	Dimensions			Entries Ø F	Fixation			Weight
	A	B	C		D	E	Ø J	
E118001	134	134	133	2x M20	117	117	8.3	5.1

For further information see individual data sheets on www.pepperl-fuchs.com

International approvals

IECEx approval

IECEx SIR 08.0065

GOST-R approval

GOST-R B00997





SMH

Ex d IIC



Instrument housing range

Enclosures with threaded cover with circular port-hole suitable to contain instruments

▶ P. 113

SEB

Ex d IIC



Electronic card housing range

Boxes with threaded cover suitable to contain electronic devices

▶ P. 114

SK

Ex d IIC



Instrument housing range for thermocouple/RTD

Boxes with threaded cover suitable to contain thermocouples and RTD

▶ P. 115

SO

Ex d IIC



Instrument housing range with port-hole

Boxes with threaded cover with circular port-hole suitable to contain signaling/visualization equipment

▶ P. 116

SO-E

Ex d IIC



Instrument housing range with extension and port-hole

Boxes with threaded cover with extension and circular port-hole suitable to contain signaling/visualization equipment

▶ P. 117



SMH - Instrument housing

Description:

The SMH instrument housing is made of aluminium alloy and has a cylindrical body and a screwed cover with circular port-hole.

Application:

The SMH instrument housing is suitable to contain analogue and digital measurement instruments such as voltmeters, ammeters, speed indicators.

Material:

Body and cover: copper free aluminium alloy.
 Port-hole: thermo-resistant tempered glass.
 Screws: stainless steel.

Certification characteristics:

Type of Protection: II 2GD Ex d IIC / Ex tD A21
 II 2GD Ex e II / Ex tD A21.
 Class of Temperature: T6/T85 °C,
 T5/T100 °C (only Ex e version).
 Protection Degree: IP66 / IP67*.
 Certificate: INERIS 01ATEX0023.
 Ambient Temperature: -50 / +60 °C (-20 / +40 °C).
 Zones: 1 – 21 – 2 – 22.

Threads:

NPT (ANSI B1.20.1).
 Metric x 1.5 (ISO 261).

Inhibiting treatments:

External standard epoxy painting RAL 7005.

On request:

Stainless steel version AISI 304 or AISI 316L.
 Support for instrument 72 x 72 (K72).
 Instrument meter.
 Version with extension (SMH-E).
 *IP67 protection with o-ring.
 Other epoxy painting colours different from the standards.
 Special inhibiting treatment.
 Cable glands for armoured or non armoured cable.

Drawing SMH

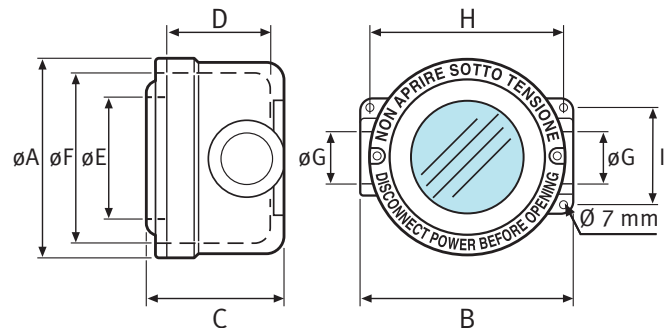

Legend:

- Ø A - Maximum external diameter.
- B - Maximum external dimension.
- C - Maximum external dimension with cover.
- D - Internal depth.
- Ø E - Port-hole diameter.
- Ø F - Internal diameter.
- Ø G - Cable entry.
- H - Fixing holes wheel base.
- I - Fixing holes wheel base.

Grounding:

Internal and external: M5 grounding point.

SMH - Data Table

Dimensions [mm] and approx. Weight [Kg]

Type	Dimensions						Entries (NPT)	Fixing		Weight
	Ø A	B	C	D	Ø E	Ø F	Ø G	H	I	
SMH	136	150	117	98	79	110	2 x 3/4"	130	65	1,6
SMH-E	136	150	221	202	79	110	2 x 3/4"	130	65	2,3

Note: - dimensions can slightly differ due to casting model tolerances.

Release date 2011-01-24 - Updated 2013-06-03 - AZ

This datasheet does not constitute any contract obligation.

Pepperl+Fuchs reserves the right to modify the products herein illustrated without prior notice. Copyright Pepperl+Fuchs srl - Italy: +39 039 6292 1

Pepperl+Fuchs Group
 www.pepperl-fuchs.com

USA: +1 330 486 0002
 pa-info@us.pepperl-fuchs.com

Germany: +49 621 776 2222
 pa-info@de.pepperl-fuchs.com

Singapore: +65 6779 9091
 pa-info@sg.pepperl-fuchs.com

PEPPERL+FUCHS
 PROTECTING YOUR PROCESS

Description:

The SEB boxes are made of aluminium alloy and circular shaped, they have a screwed blind cover and have different configuration of cable entry.

Application:

The SEB instrument housing is suitable to contain electronic devices to measure, control and elaborate signals of physical parameters.

Materials:

Body and cover: copper free aluminium alloy.
Screws: stainless steel.

Certification characteristics:

Type of Protection: II 2GD Ex d IIC / Ex tD A21
II 2GD Ex e II / Ex tD A21.
Class of Temperature: T6/T85 °C,
T5/T100 °C (only Ex e version).
Protection Degree: IP66 / IP67*.
Certificate: INERIS 01ATEX0023.
Ambient Temperature: -50 / +60 °C (-20 / +40 °C).
Zones: 1 – 21 – 2 – 22.

Threads:

NPT (ANSI B1.20.1).
Metric x 1.5 (ISO 261).

Drawing SEB

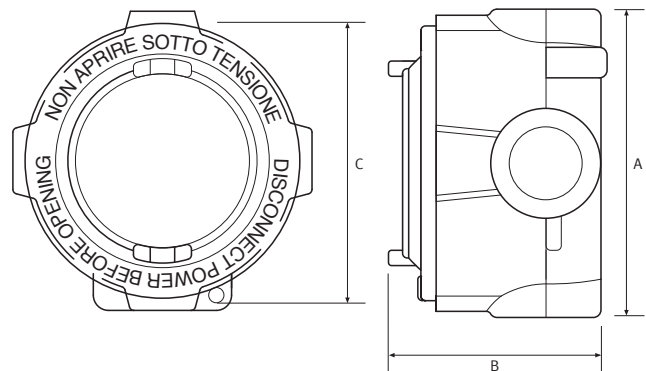

Legend:

A - Maximum external dimension.
B - Maximum external dimension with cover.
Ø C - External diameter.

Grounding:









Internal and external: M5 grounding point.

On request:

Stainless steel version AISI 304 or AISI 316L.
*IP67 protection with o-ring.
Extension 76 mm.
Cover with port-hole.
Anti loosening cover.
Fixation brackets.
External epoxy painting.
Special inhibiting treatment.
Cable glands for armoured or non armoured cable.

SEB - Data Table

Dimensions [mm] and approx. Weight [Kg]

Type	Entries		Dimensions			Weight	
	n°	Ø [NPT]	A	B	Ø C		
	SEB/B 16	2	1/2"	100	75	90	0,45
	SEB/B 26	2	3/4"	100	75	90	0,45
	SEB/C 16	2	1/2"	100	75	90	0,45
	SEB/C 26	2	3/4"	100	75	90	0,45
	SEB/D 16	3	1/2"	100	75	90	0,45
	SEB/D 26	3	3/4"	100	75	90	0,45
	SEB/L 16	2	1/2"	100	75	90	0,45
	SEB/L 26	2	3/4"	100	75	90	0,45
	SEB/M 16	3	1/2"	100	75	90	0,45
	SEB/M 26	3	3/4"	100	75	90	0,45
	SEB/T 16	3	1/2"	100	75	90	0,45
	SEB/T 26	3	3/4"	100	75	90	0,45
	SEB/W 16	4	1/2"	100	75	90	0,45
	SEB/W 26	4	3/4"	100	75	90	0,45
	SEB/X 16	4	1/2"	100	75	90	0,45
	SEB/X 26	4	3/4"	100	75	90	0,45
	SEB/J 16	5	1/2"	100	75	90	0,45
	SEB/J 26	5	3/4"	100	75	90	0,45

Note: - standard external grounding point close to the lower cable entry.

Release date 2011-01-24 - Updated 2013-06-03 - A2

This datasheet does not constitute any contract obligation.

Pepperl+Fuchs reserves the right to modify the products herein illustrated without prior notice. Copyright Pepperl+Fuchs srl - Italy: +39 039 6292 1

SK - Instrument housing for thermocouple / RTD

Description:

The SK instrument housing is made of aluminium alloy and circular shaped. They have a screwed blind cover and have different configuration for cable entry.

Application:

The SK instrument housing is suitable to contain thermocouples/ RTDs (Resistance Temperature Detectors) or other thermometer elements, electronic transmitters or equivalent devices.

Materials:

Body and cover: copper free aluminium alloy.
Screws: stainless steel.

Certification characteristics:

Type of Protection: II 2GD Ex d IIC / Ex tD A21
II 2GD Ex e II / Ex tD A21.
Class of Temperature: T6/T85 °C,
T5/T100 °C (only Ex e version).
Protection Degree: IP66 / IP67*.
Certificate: INERIS 01ATEX0023.
Ambient Temperature: -50 / +60 °C (-20 / +40 °C).
Zones: 1 – 21 – 2 – 22.

Threads:

NPT (ANSI B1.20.1).
Metric x 1.5 (ISO 261).

Drawing SK

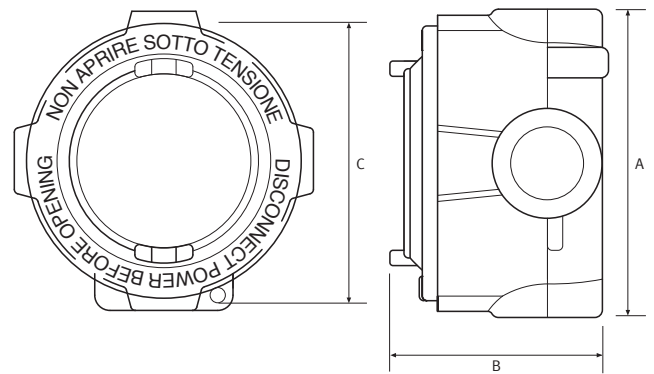

Legend:

- A - Maximum external dimension.
- B - Maximum external dimension with cover.
- Ø C - External diameter.

Grounding:

Internal and external: M5 grounding point.

On request:

- Stainless steel version AISI 304 or AISI 316L.
- Thermocouple.
- *IP67 protection with o-ring.
- Cover with port-hole.
- Anti loosening cover.
- Fixation brackets.
- External epoxy painting.
- Special inhibiting treatment.
- Cable glands for armoured or non armoured cable.

SK - Data Table

Dimensions [mm] and approx. Weight [Kg]

Type	Entries		Dimensions			Weight	
	n°	Ø [NPT]	A	B	Ø C		
	SK/B 16	2	1/2"	100	75	90	0,45
	SK/B 26	2	3/4"	100	75	90	0,45
	SK/D 16	3	1/2"	100	75	90	0,45
	SK/D 26	3	3/4"	100	75	90	0,45
	SK/M 16	3	1/2"	100	75	90	0,45
	SK/M 26	3	3/4"	100	75	90	0,45
	SK/W 16	4	1/2"	100	75	90	0,45
	SK/W 26	4	3/4"	100	75	90	0,45
	SK/J 16	5	1/2"	100	75	90	0,45
	SK/J 26	5	3/4"	100	75	90	0,45

Note: - standard external grounding point close to the lower cable entry.

Release date 2011-01-24 – Updated 2013-06-03 - A2

This datasheet does not constitute any contract obligation.

Pepperl+Fuchs reserves the right to modify the products herein illustrated without prior notice. Copyright Pepperl+Fuchs srl - Italy: +39 039 6292 1

Pepperl+Fuchs Group
www.pepperl-fuchs.com

USA: +1 330 486 0002
pa-info@us.pepperl-fuchs.com

Germany: +49 621 776 2222
pa-info@de.pepperl-fuchs.com

Singapore: +65 6779 9091
pa-info@sg.pepperl-fuchs.com

PEPPERL+FUCHS
PROTECTING YOUR PROCESS

SO - Instrument Housing with Port-hole

Description:

The SO instrument housing is made of aluminium alloy and circular shaped. It has a screwed cover with circular port-hole and has different configuration for cable entry. Please refer to the product SO-E showing this enclosure with extension.

Application:

The SO instrument housing is suitable to contain signalling/ visualization equipment.

Material:

Body and cover: copper free aluminium alloy.
 Port-hole: thermo-resistant tempered glass.
 Screws: stainless steel.

Certification characteristics:

Type of Protection: II 2GD Ex d IIC / Ex tD A21
 II 2GD Ex e II / Ex tD A21.
 Class of Temperature: T6 / T85 °C,
 T5 / T100 °C (only Ex e version).
 Protection Degree: IP66 / IP67*.
 Certificate: INERIS 01ATEX0023.
 Ambient Temperature: -50 / +60 °C (-20 / +40 °C).
 Zones: 1 – 21 – 2 – 22.

Threads:

NPT (ANSI B1.20.1).
 Metric x 1.5 (ISO 261).

Drawing SO

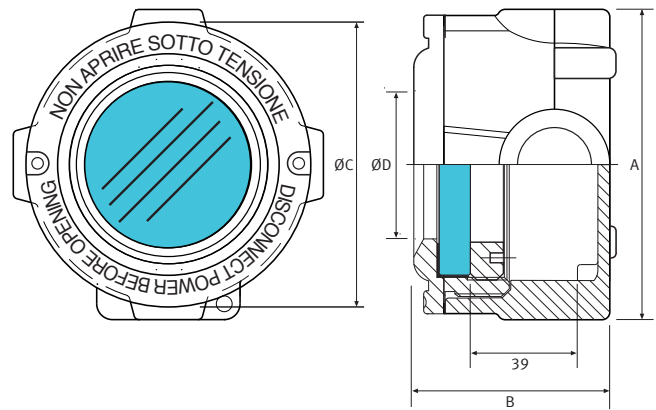

Legend:

A - Maximum external dimension.
 B - Maximum external dimension with cover.
 Ø C - External diameter.
 Ø D - Port-hole diameter.

Drawing dimensions [mm]

Grounding:

Internal and external: M5 grounding point.

On request:

Stainless steel version AISI 304 or AISI316L.
 *IP67 protection with o-ring.
 Anti loosening cover.
 Fixation brackets.
 External epoxy painting.
 Special inhibiting treatment.
 Cable glands for armoured or non armoured cable.

SO - Data Table

Dimensions [mm] and approx. Weight [Kg]

Type	Entries		Dimensions				Weight	
	n°	Ø [NPT]	A	B	Ø C	Ø D		
	SO/A 16	1	1/2"	100	67	90	49	0,5
	SO/A 26	1	3/4"	100	67	90	49	0,5
	SO/B 16	2	1/2"	100	67	90	49	0,5
	SO/B 26	2	3/4"	100	67	90	49	0,5
	SO/C 16	2	1/2"	100	67	90	49	0,5
	SO/C 26	2	3/4"	100	67	90	49	0,5
	SO/D 16	3	1/2"	100	67	90	49	0,5
	SO/D 26	3	3/4"	100	67	90	49	0,5
	SO/L 16	2	1/2"	100	67	90	49	0,5
	SO/L 26	2	3/4"	100	67	90	49	0,5
	SO/M 16	3	1/2"	100	67	90	49	0,5
	SO/M 26	3	3/4"	100	67	90	49	0,5
	SO/T 16	3	1/2"	100	67	90	49	0,5
	SO/T 26	3	3/4"	100	67	90	49	0,5
	SO/W 16	4	1/2"	100	67	90	49	0,5
	SO/W 26	4	3/4"	100	67	90	49	0,5

Note: - standard external grounding point close to the lower cable entry.

Release date 2011-01-24 – Updated 2013-06-03 - A2

This datasheet does not constitute any contract obligation.

Pepperl+Fuchs reserves the right to modify the products herein illustrated without prior notice. Copyright Pepperl+Fuchs srl - Italy: +39 039 6292 1

SO-E - Instrument housing with port-hole and extension

Description:

The SO-E instrument housing is made of aluminium alloy and circular shaped. It has a screwed cover with circular port-hole, extension and has different configuration for cable entry.

Application:

The SO-E instrument housing is suitable to contain signalling / visualization equipment.

Material:

Body and cover: copper free aluminium alloy.
 Port-hole: thermo-resistant tempered glass.
 Screws: stainless steel.

Certification characteristics:

Type of Protection: II 2GD Ex d IIC / Ex tD A21
 II 2GD Ex e II / Ex tD A21.
 Class of Temperature: T6 / T85 °C,
 T5 / T100 °C (only Ex e version).
 T4 / T135 °C.
 Protection Degree: IP66 / IP67*.
 Certificate: INERIS 01ATEX0023.
 Ambient Temperature: -50 / +60 °C (-20 / +40 °C).
 Zones: 1 – 21 – 2 – 22.

Threads:

NPT (ANSI B1.20.1).
 Metric x 1.5 (ISO 261).

Drawing SO-E

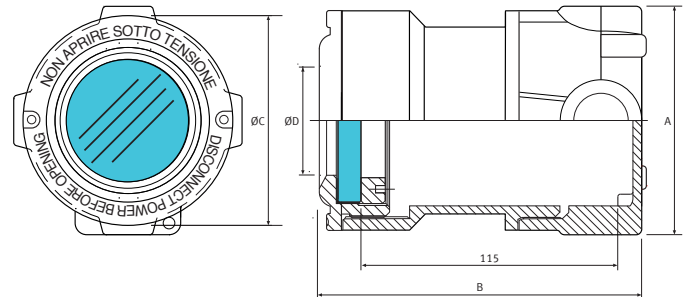

Legend:

- A - Maximum external dimension.
- B - Maximum external dimension with cover.
- Ø C - External diameter.
- Ø D - Port-hole diameter.

Drawing dimensions [mm].

Grounding:

Internal and external: M5 grounding point.

On request:

- *IP67 protection with o-ring.
- Anti loosening cover.
- Fixation brackets.
- External epoxy painting.
- Special inhibiting treatment.
- Cable glands for armoured or non armoured cable.

SO-E - Data Table

Dimensions [mm] and approx. Weight [Kg]

Type	Entries		Dimensions				Weight	
	n°	Ø [NPT]	A	B	Ø C	Ø D		
	SO-E/A 16	1	1/2"	100	144	90	49	0,85
	SO-E/A 26	1	3/4"	100	144	90	49	0,85
	SO-E/B 16	2	1/2"	100	144	90	49	0,85
	SO-E/B 26	2	3/4"	100	144	90	49	0,85
	SO-E/C 16	2	1/2"	100	144	90	49	0,85
	SO-E/C 26	2	3/4"	100	144	90	49	0,85
	SO-E/D 16	3	1/2"	100	144	90	49	0,85
	SO-E/D 26	3	3/4"	100	144	90	49	0,85
	SO-E/L 16	2	1/2"	100	144	90	49	0,85
	SO-E/L 26	2	3/4"	100	144	90	49	0,85
	SO-E/M 16	3	1/2"	100	144	90	49	0,85
	SO-E/M 26	3	3/4"	100	144	90	49	0,85
	SO-E/T 16	3	1/2"	100	144	90	49	0,85
	SO-E/T 26	3	3/4"	100	144	90	49	0,85
	SO-E/W 16	4	1/2"	100	144	90	49	0,85
	SO-E/W 26	4	3/4"	100	144	90	49	0,85

Note: - standard external grounding point close to the lower cable entry.

Release date 2011-01-24 - Updated 2013-06-03 - AZ



FFCM

Ex d IIC

Compact limit switch with selection of actuators

▶ P. 121



This datasheet does not constitute any contract obligation.

Pepperl+Fuchs reserves the right to modify the products herein illustrated without prior notice. Copyright Pepperl+Fuchs srl - Italy: +39 039 6292 1

Pepperl+Fuchs Group
www.pepperl-fuchs.com

USA: +1 330 486 0002
pa-info@us.pepperl-fuchs.com

Germany: +49 621 776 2222
pa-info@de.pepperl-fuchs.com

Singapore: +65 6779 9091
pa-info@sg.pepperl-fuchs.com

 **PEPPERL+FUCHS**
PROTECTING YOUR PROCESS

119



Description:

The FFCM compact limit switch is made of aluminium alloy. It has a screwed blind cover and six types of different external actuators in order to cover various applications.

Application:

The FFCM limit switch is used to open and/or close an electric circuit after pressure on external actuators. It finds several applications in auxiliary circuits (shutters, fillers, boxing machines, etc.).

Materials:

Body and cover: copper free aluminium alloy.
Screws: stainless steel.
Actuator: plastic material.

Certification characteristics:

Type of Protection: II 2GD Ex d IIC / Ex tD A21.
Class of Temperature: T6 / T85 °C.
Protection Degree: IP65.
Certificate: INERIS 02ATEX0040.
Ambient Temp.: -20 / +60 °C.
Zones: 1 – 21 – 2 – 22.

Threads:

NPT (ANSI B1.20.1).

Inhibiting treatments:

Standard epoxy painting RAL 7000.

On request:

Other epoxy painting colours different by the standards.
Special inhibiting treatment.
Other type of threads [ISO7/1 (UNI6125), Metric x 1.5 (ISO 261)].
Cable glands for armoured or non armoured cable.

Drawing FFCM

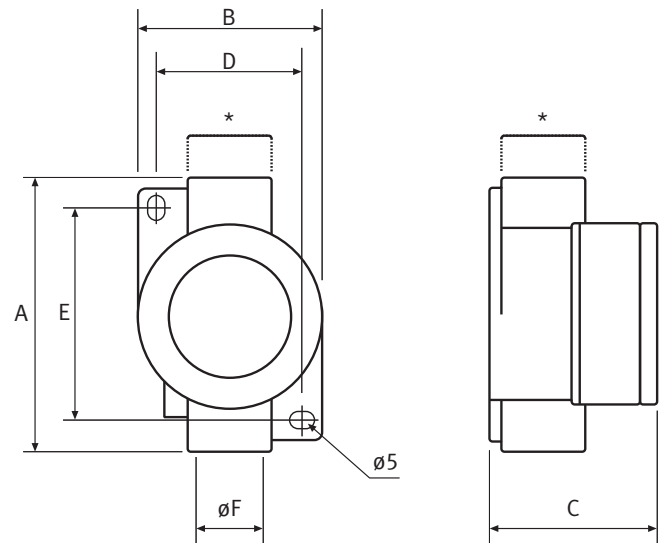

Legend:





- A - Maximum external dimension.
- B - Maximum external dimension with mounting brackets.
- C - Maximum external dimension with cover.
- D - Fixing holes wheel base.
- E - Fixing holes wheel base.
- Ø F - Cable entry diameter.
- * see "Data table" for different types of "Head".

Grounding:

External: M4 grounding point.
Internal: M3 grounding point.

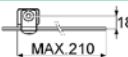
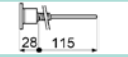
FFCM - Data table

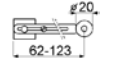
Dimensions [mm] and approx. Weight [Kg]

* Head	Type	Single pole contact	Dimensions					Cable entry Ø F [NPT]	Weight
			A	B	C	D	E		
	FFCM/A	1 NO + 1 NC	97	68	57	42	68	1/2"	0,4
	FFCM/F	1 NO + 1 NC	97	68	57	42	68	1/2"	0,4
	FFCM/P	1 NO + 1 NC	97	68	57	42	68	1/2"	0,4
	FFCM/AR	1 NO + 1 NC	97	68	57	42	68	1/2"	0,4
	FFCM/L	1 NO + 1 NC	97	68	57	42	68	1/2"	0,4

Note: 1) FFCM contact 1NO+1NC with positive break (snap action), Max. rated current 10 A according to IEC 337-1 and maximum voltage 600 V.
2) Maximum section wire: 2.5 mm².

Release date 2011-03-08 - A0 - Updated 2013-06-03 - A2

This datasheet does not constitute any contract obligation.

Pepperl+Fuchs reserves the right to modify the products herein illustrated without prior notice. Copyright Pepperl+Fuchs srl - Italy: +39 039 6292 1

Pepperl+Fuchs Group
www.pepperl-fuchs.com

USA: +1 330 486 0002
pa-info@us.pepperl-fuchs.com

Germany: +49 621 776 2222
pa-info@de.pepperl-fuchs.com

Singapore: +65 6779 9091
pa-info@sg.pepperl-fuchs.com

PEPPERL+FUCHS
PROTECTING YOUR PROCESS

Staying in touch. The world over.

Good customer relationships need care and attention. They are an indication of genuine interest, trust, and a cooperative spirit: the foundation of Pepperl+Fuchs' strengths. No matter where you might be, we are always nearby. And we speak your language – in more than 140 countries the world over.

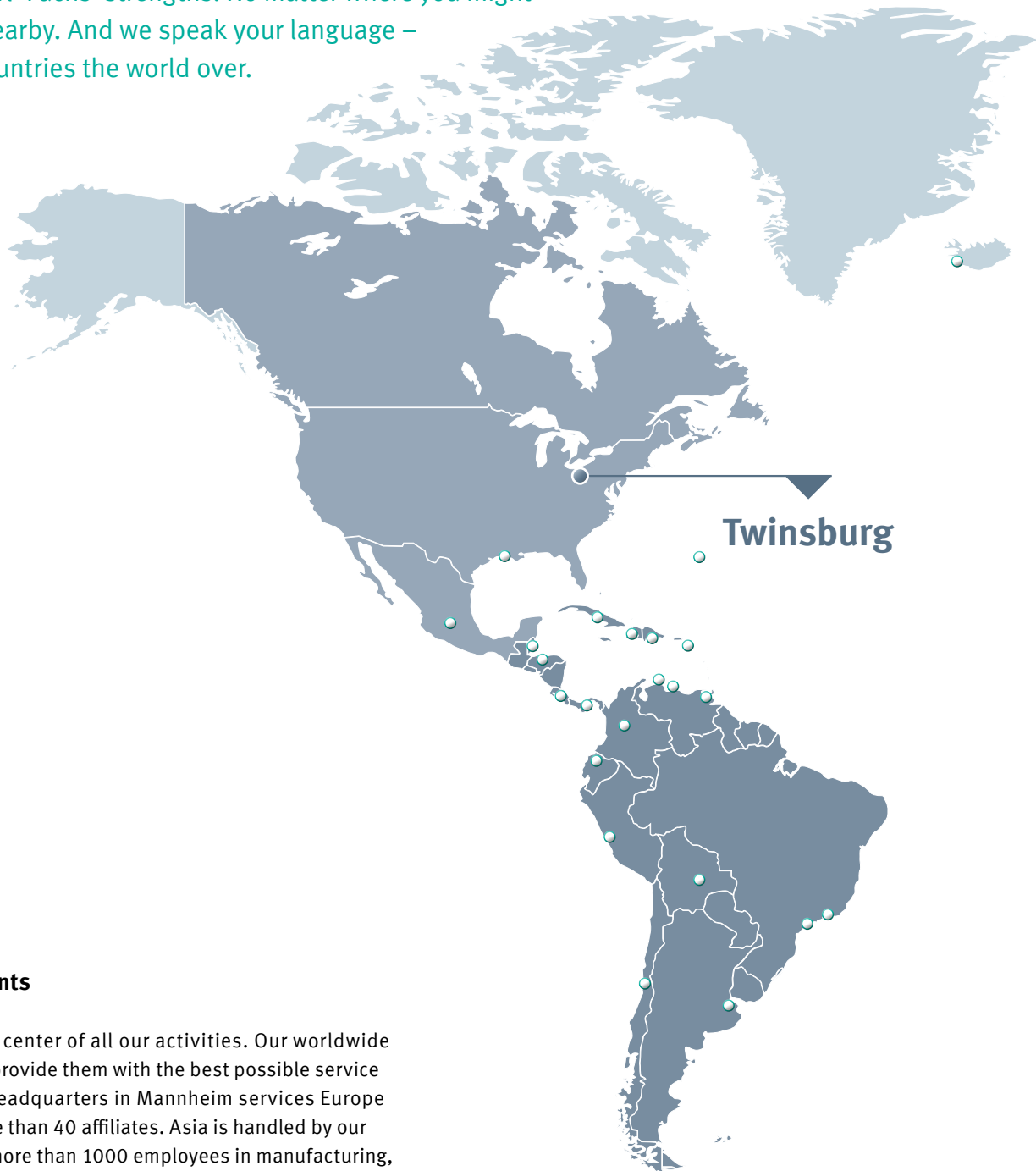

Twinsburg

At home on all continents

Our customers are at the center of all our activities. Our worldwide network ensures that we provide them with the best possible service and support. Our world headquarters in Mannheim services Europe through a network of more than 40 affiliates. Asia is handled by our office in Singapore, with more than 1000 employees in manufacturing, service, and sales. And our North American headquarters in Twinsburg, Ohio, is responsible for a comprehensive network of offices and sales partners in the USA, Canada, and Mexico.

No matter where in the world you may be, Pepperl+Fuchs is right nearby – and always there for you.

-  **North America**
USA, Canada, Mexico
-  **South America**
Brazil, Argentina

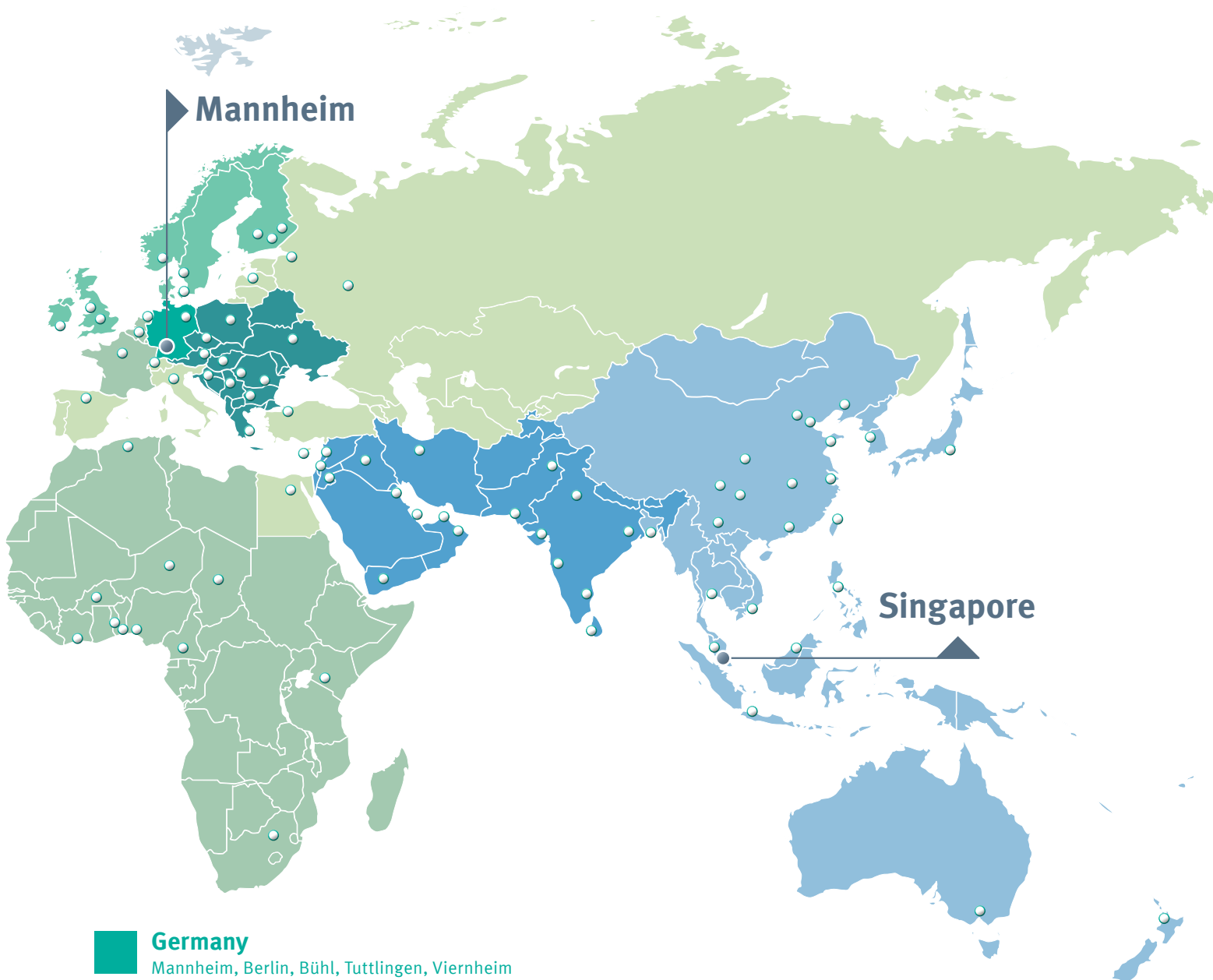

Mannheim

Singapore

- Germany**
Mannheim, Berlin, Bühl, Tuttlingen, Viernheim
- Northern Europe**
Great Britain, Norway, Ireland, Denmark, Sweden
- Eastern Europe**
Austria, Poland, Hungary, Czech Republic
- Western Europe & Africa**
Netherlands, Belgium, Luxembourg, France, Africa
- Southern Europe & Russia**
Italy, Switzerland, Spain, Turkey, Egypt, Russia

- South-western Asia & India**
India, UAE, Dubai
- Asia-Pacific**
Singapore, Japan, Australia, China, Korea

YOUR APPLICATION. OUR CHALLENGE.

PROCESS INTERFACES

- Intrinsically safe barriers
- Signal conditioners
- Fieldbus infrastructure
- Remote I/O systems
- HART interface solutions
- Level measurement
- Purge and pressurization systems
- Industrial monitors and HMI solutions
- Explosion protection equipment
- Wireless solutions
- Solutions with process interfaces

INDUSTRIAL SENSORS

- Proximity sensors
- Photoelectric sensors
- Industrial vision
- Ultrasonic sensors
- Rotary encoders
- Positioning systems
- Inclination and acceleration sensors
- AS-Interface
- Identification systems
- Logic control units



www.pepperl-fuchs.com

 **PEPPERL+FUCHS**