

LinMot® F01-37S and F01-48 Guides

Version 1.67e

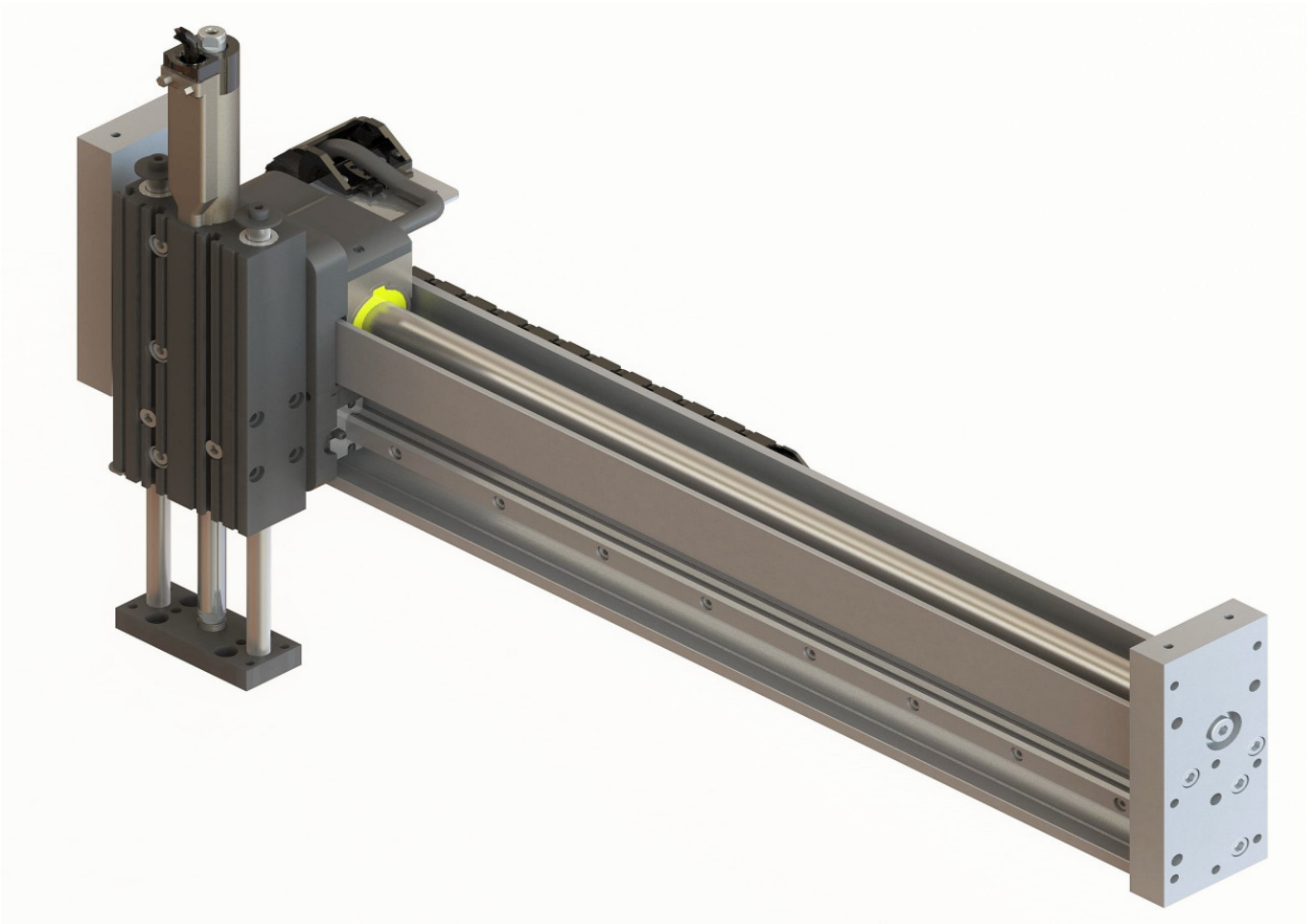

CAUTION

LINMOT SLIDERS CONTAIN NEODYMIUM MAGNETS WHICH MAY DISTURB OR DAMAGE MAGNETIC DATA CARRIERS AND DELICATE ELECTRONIC EQUIPMENT MERELY BY COMING CLOSE TO THEM.



WHEN HANDLING SLIDERS BE AWARE THAT, DUE THE STRONG MAGNETIC ATTRACTION, INJURY FROM FINGERS BEING PINCHED BETWEEN THE SLIDER AND NEARBY STEEL PARTS IS A VERY REAL POSSIBILITY IF CAUTION IS NOT EXERCISED.



THE SLIDERS OF LINMOT[®] MOTORS CAN REACH TEMPERATURES WHICH MAY CAUSE BURNS UPON BEING TOUCHED.



THE SLIDERS AND SHAFTS OF LINMOT[®] LINEAR-ROTARY MOTORS ARE FAST-MOVING MACHINE PARTS. THE USER MUST TAKE ALL NECESSARY PRECAUTIONS TO PREVENT THEIR BEING TOUCHED (PROVIDE COVERS, PROTECTION AGAINST TOUCHING ETC.).



The complete documentation including technical data, drawings and accessories can be downloaded from the download area on the web page www.LinMot-USA.com .

CAD files and STEP files can be downloaded from the CAD download area on the web page www.LinMot-USA.com .

1 Inhaltsverzeichnis

EXAMPLE LAYOUT	5
DESCRIPTION	6
TECHNICAL DATA FOR F01-37 GUIDE	8
Dimensions and mass of F01-37S guides.....	9
Moving masses 37S guides.....	9
TECHNICAL DATA FOR F01-48 GUIDE	10
Dimensions and mass of F01-48 guides.....	11
Moving masses of F01-48 guides.....	11
DRIVE SETUP	12
WIZARD LINMOT-TALK SOFTWARE	12
Select the right stator and slider length.....	12
Define Payload.....	13
PID Controller.....	13
Homing.....	14
Full length of stroke.....	15
ORDER INFORMATION FOR GUIDE F01-37S	16
1. Step: Select F01-37S guide.....	16
2. Step: Select Slider.....	16
3. Step: Select type and quantity of Carriage-Kit.....	17
4. Step: Select type and quantity of Stator.....	17
5. Step: Select Trailing chain kit or trailing chain (optional).....	18
6. Step: Select Trailing chain cables (high-flex cable).....	19
7. Step: External Sensor-Kit (optional).....	20
8. Step: Magnetic strip (optional).....	20
9. Step: Adapter plate for linear rotary motors (optional).....	21
10. Step: Nuts for T-Slot (optional).....	21
Order example:.....	22
ORDER INFORMATION FOR GUIDE F01-48	23
1. Step: Select F01-48 guide.....	23
2. Step: Select Slider.....	23
3. Step: Select quantity of Carriage-Kit.....	24
4. Step: Select type and quantity of Stators and Flanges.....	24
5. Step: Select Trailing chain kit or trailing chain (optional).....	25
6. Step: Select Trailing chain cables (high-flex cable).....	26
7. Step: External Sensor-Kit (optional).....	27
8. Step: Magnetic strip (optional).....	27
9. Step: Adapter plate for linear rotary motors (optional).....	28
10. Step: Nuts for T-Slot (optional).....	28
DIMENSIONS SEE DRAWINGS	28
GANTRY DESIGN	29
Assembly of Gantry design.....	29
COMBINATION OF F01-48 AND F01-37S GUIDES	30
Semi gantry design.....	30
MULTIPLE CARRIER DESIGN	31

MOUNTING INSTRUCTIONS.....	32
ASSEMBLING INSTRUCTIONS.....	33
Direction of the motor cable	33
Assembly and disassembly of the motors and carriages	33
Assembly of the slider.....	35
Assembly of the railway.....	35
Assembly of Trailing Chain Kit.....	36
Assembly of an external sensor-kit.....	37
BEARING LOAD ON F01-37S GUIDES.....	38
Static and dynamic bearing loads F_x und F_y	38
Calculation of the static load bearing F_x and F_y	38
Static and dynamic moment load M_{xyz}	39
ELECTRICAL CONNECTION OF TH PS01-37S STATORS	40
Installation of the motor cable.....	41
MAINTENANCE.....	42
Maintenance of Carriages.....	42
Relubrication of carriages.....	42
Quantity of lubricant for carriages.....	42
Lubricant for carriages.....	42
Maintenance of LinMot Motors.....	43
Storage / transport.....	44
CAUTION: HANDLING INSTRUCTIONS FOR SLIDERS.....	45
DRAWINGS F01-37S.....	46
Stroke Range F01-37S guide	46
Dimensions F01-37S guide.....	47
Dimensions F01-37S-AP ground plate.....	48
Dimensions F01-37S end plates.....	49
Dimensions F01-37S T-slots.....	50
Dimensions with H01-23x86 guide.....	51
Dimensions with H01-37x166 guide.....	52
Dimensions with PR01-52x40-R/37x120F-HP-C-80/-L.....	53
Dimensions with PR01-52x60-R/37x120F-HP-C-100/-L.....	54
Dimensions with PR01-52x60-R/37x120F-HP-C-100-G.....	55
DRAWINGS F01-48.....	56
Stroke Range F01-48 guide	56
Dimensions F01-48 guide	57
Dimensions F01-48 ground plate.....	58
Dimensions F01-48 end plate.....	59
DECLARATION OF CONFORMITY CE-MARKING.....	60
CONTACT ADDRESS:.....	61

Example Layout

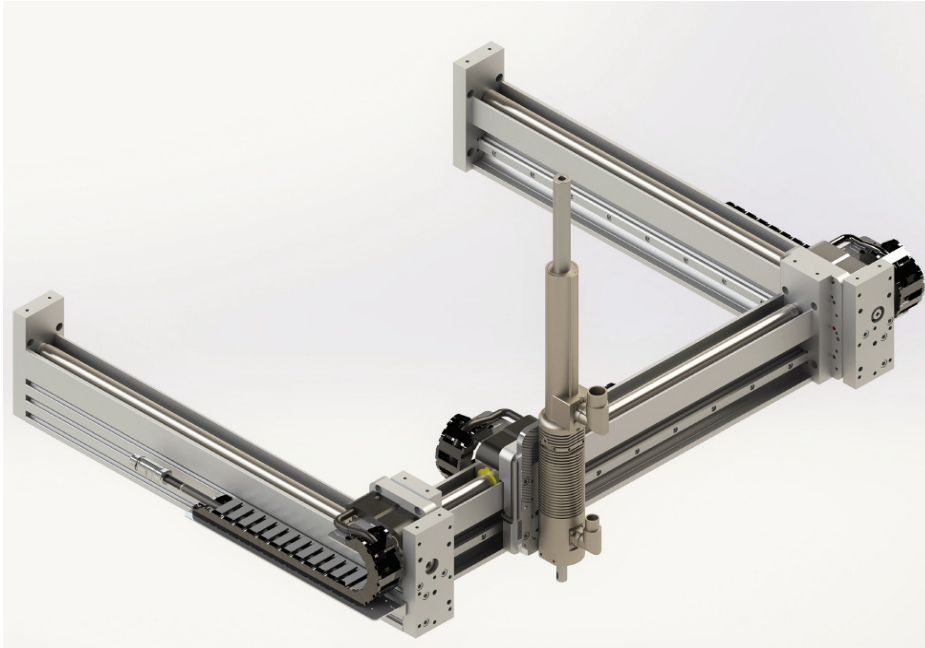

Figure 1: Gantry-Design with three F01-37S guides



Figure 2: F01-37S guide with two independent motors on the same track

Description

The LinMot F01-37S and F01-48 guides are moving stator applications with tubular linear motors. The mechanical design is based on a special aluminum profile on which a high precision profile rail guide is attached. Use of ball bearings in the carriages guarantee a reliable and smooth operation. The design of both guides is very similar but different in the dimensions.

F-guides can be mounted together into a gantry design (Fig. 1) without any additional adapters. It is also possible to run more than one motor on the same guide (Fig. 2). There are two sizes of motors available for each size of F-guide; the PS01-37Sx60 offers highest velocity on a very short design while the PS01-37Sx120 presents double the peak force with an additional 60mm length. The motors of the PS01-48 series offers a peak force up to 1000 N (250 lbf).

Together with the H01 guides for the vertical axis (Fig. 3) and the linear rotary motors of the PR01-52 series (Fig. 4&5) the F-guides offer a powerful toolbox for any automation task.

Figure 3: F01-37S Guide with mounted H01-23 guide for z-axis

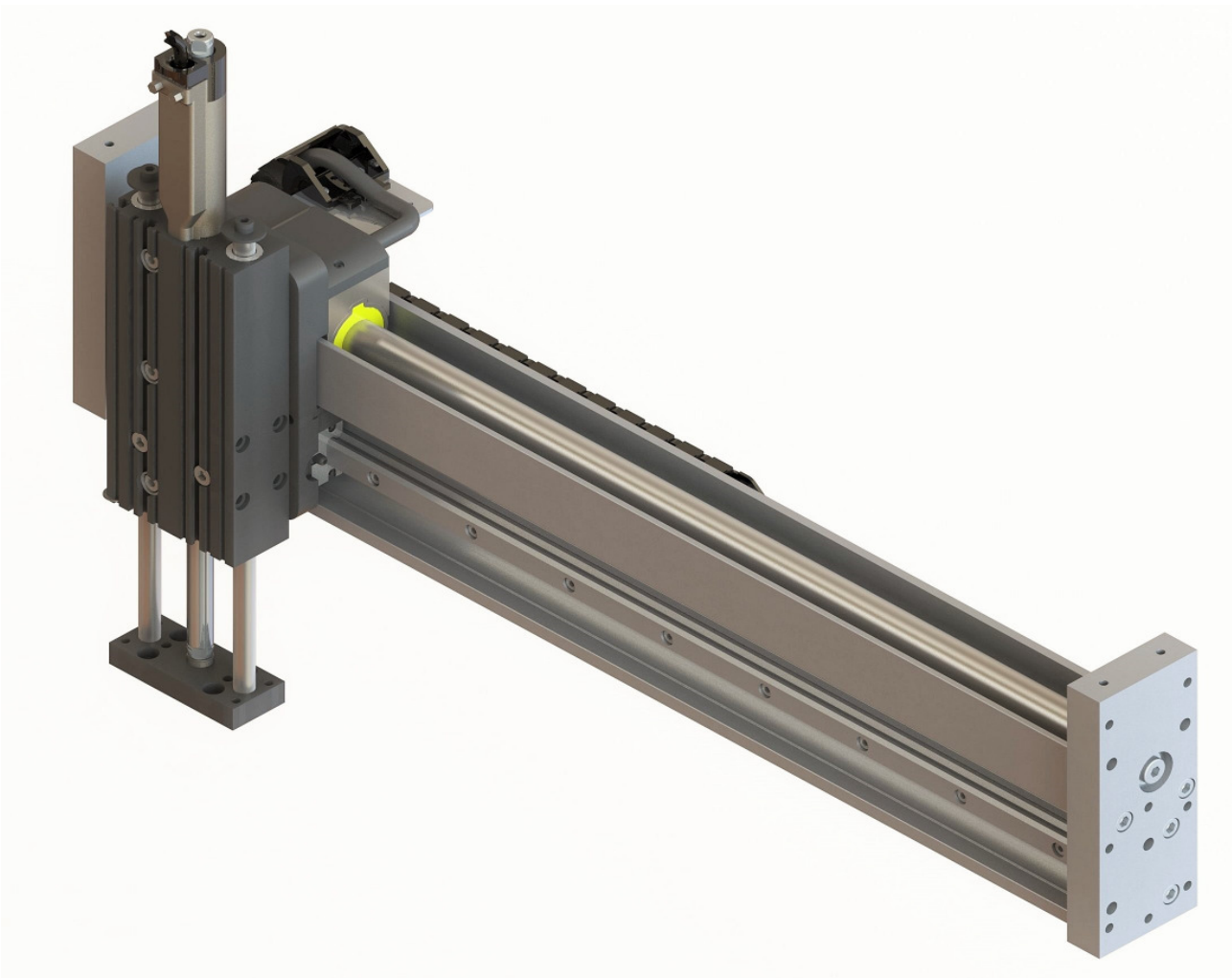

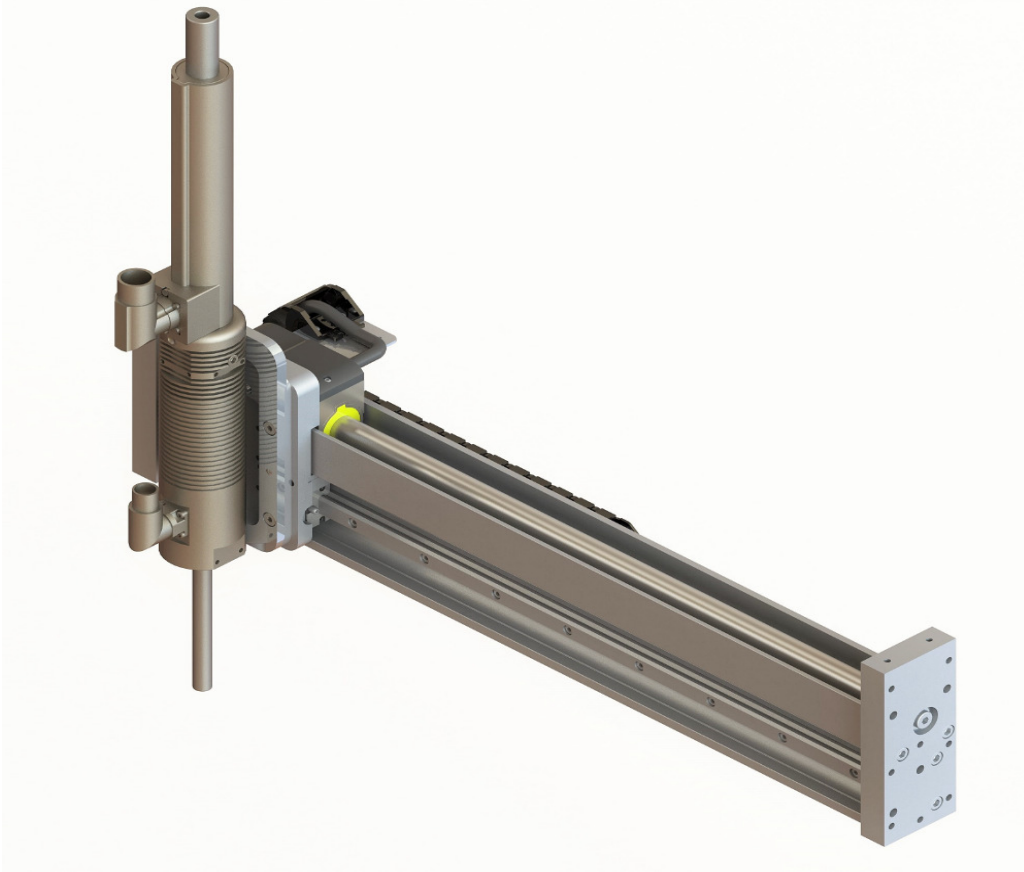

Figure 4: F01-37S Guide with mounted linear rotary motor PR01-52



Figure 5: Gantry Design with mounted linear rotary motor PR01-52

Technical data for F01-37 Guide

		value	Note
Static load rating	C	15'400 N (3462 lbf)	See chapter bearing load
Dynamic load rating	C ₀	8'400 N (1888 lbf)	See chapter bearing load
Static moment load	M _{x0}	103 Nm (75.9 lb ft)	See chapter bearing load
	M _{y0}	90 Nm (66.3 lb ft)	See chapter bearing load
	M _{z0}	90 Nm (66.3 lb ft)	See chapter bearing load
Dynamic moment load	M _x	56 Nm (41.3 lb ft)	See chapter bearing load
	M _y	49 Nm (36.1 lb ft)	See chapter bearing load
	M _z	49 Nm (36.1 lb ft)	See chapter bearing load
Max velocity	v _{max}	5 m/s (196 in/s)	Depending on motor
Max acceleration	a _{max}	75 m/s ² (2952 in/s ²)	Depending on motor
Stator PS01-37Sx60			
Peak Force	F _{peak}	122 N (27.4 lbf)	
Continuous Force	F _{cont}	20 N (4.5 lbf)	
Max phase current @ 72VDC	I _{max}	12 A	
Moving mass total	m _{lin tot}	1100 g (2.42 lb)	Stator, carriage, adapter plate
Repeatability without external Sensor		+/- 0.05 mm (+/- 0.002 in)	
Repeatability with external Sensor		+/- 0.01 mm (+/- 0.0004 in)	With external sensor
Friction (estimation)	F _r	7 N (1.6 lbf)	Dependent on application
Stator PS01-37Sx120			
Peak Force	F _{peak}	255 N (57.3 lbf)	
Continuous Force	F _{cont}	35 (7.8 lbf)	
Max phase current @ 72VDC	I _{max}	15 A	
Moving mass total	m _{lin tot}	1470 g (3.24 lb)	Stator, carriage, adapter plate
Repeatability without external Sensor		+/- 0.05 mm (+/- 0.002 in)	
Repeatability with external Sensor		+/- 0.01 mm (+/- 0.0004 in)	With external sensor
Friction (estimation)	F _r	7 N (1.6 lbf)	Dependent on application

To calculate the motor specific application data we recommend to use the sizing tool LinMot Designer. (see Download sector on www.LinMot.com)

Dimensions and mass of F01-37S guides

Description	Part-No	Length total	Mass
F01-37Sx300	0150-5453	330 mm (13.0 in)	3430 g (7.57 lb)
F01-37Sx400	0150-5449	430 mm (16.9 in)	4310 g (9.5 lb)
F01-37Sx500	0150-5450	530 mm (20.9 in)	5220 g (11.51 lb)
F01-37Sx600	0150-5424	630 mm (24.8 in)	6100 g (13.45 lb)
F01-37Sx800	0150-5425	830 mm (32,7 in)	7860 g (17.33 lb)
F01-37Sx1000	0150-5426	1030 mm (40.6 in)	9640 g (21.25 lb)
F01-37Sx1200	0150-5427	1230 mm (48.4 in)	11400 g (25.13 ib)
F01-37Sx1400	0150-5428	1430 mm (56.3 in)	13200 g (29.10 lb)
F01-37Sx1600	0150-5429	1630 mm (64.2 in)	14930 g (32.92 lb)
F01-37Sx2000	0150-5430	2030 mm (79.9 in)	18490 g (40.76 lb)

Mass including end-plates, profile rail and slider (without stator and adapter plate)

Moving masses 37S guides

Stator PS01-37Sx60-HP-N-AGI with	carrier kit F01-37S/FWK:	1100 g (2.42 lb)
	carrier kit F01-37S/FWK-F:	1290 g (2.84 lb)
Stator PS01-37Sx120-HP-N-AGI with	carrier kit F01-37S/FWK:	1470 g (3.24 lb)
	carrier kit F01-37S/FWK-F:	1660 g (3.66 lb)

Technical data for F01-48 Guide

		value	Note
Static load rating	C	30'800 N (6924 lbf)	See chapter bearing load
Dynamic load rating	C ₀	16'800 N (3776 lbf)	See chapter bearing load
Static moment load	M _{x0}	206 Nm (151.8 lb ft)	See chapter bearing load
	M _{y0}	180 Nm (132.6 lb ft)	See chapter bearing load
	M _{z0}	180 Nm (132.6 lb ft)	See chapter bearing load
Dynamic moment load	M _x	112 Nm (82.6 lb ft)	See chapter bearing load
	M _y	98 Nm (72.2 lb ft)	See chapter bearing load
	M _z	98 Nm (72.2 lb ft)	See chapter bearing load
Max velocity	v _{max}	3 m/s (118 in/s)	Depending on motor
Max acceleration	a _{max}	50 m/s ² (1968 in/s ²)	Depending on motor
Stator PS01-48X240F-C			
Peak Force	F _{peak}	550 N (123.6 lbf)	
Continuous Force	F _{cont}	145 N (32.6 lbf)	
Max phase current @ 72VDC	I _{max}	26 A	
Moving mass total	m _{lin tot}	4900 g (10.8 lb)	Stator, carriage, adapter plate
Repeatability without external Sensor		+/- 0.05 mm (+/- 0.002 in)	
Repeatability with external Sensor		+/- 0.01 mm (+/- 0.0004 in)	With external sensor
Friction (estimation)	F _r	30 N (6.7 lbf)	Dependent on application
Stator PS01-48X360F-C			
Peak Force	F _{peak}	1024 N (230.1 lbf)	
Continuous Force	F _{cont}	203 N (45.7 lbf)	
Max phase current @ 72VDC	I _{max}	32 A	
Moving mass total	m _{lin tot}	6250 g (13.8 lb)	Stator, carriage, adapter plate
Repeatability without external Sensor		+/- 0.05 mm (+/- 0.002 in)	
Repeatability with external Sensor		+/- 0.01 mm (+/- 0.0004 in)	With external sensor
Friction (estimation)	F _r	34 N (7.6 lbf)	Dependent on application

To calculate the motor specific application data we recommend to use the sizing tool LinMot Designer. (see Download sector on www.LinMot.com)

Dimensions and mass of F01-48 guides

Description	Part-No	Length total	Mass
F01-48x500	0150-5469	540 mm (21.3 in)	6.93 kg (15.27 lb)
F01-48x620	0150-5470	660 mm (26.0 in)	8.19 kg (18.04 lb)
F01-48x800	0150-5471	840 mm (33.1 in)	10.19 kg (22.46 lb)
F01-48x1010	0150-5472	1050 mm (41.3 in)	12.45 kg (27.44 lb)
F01-48x1220	0150-5473	1260 mm (49,6 in)	14.70 kg (32.42 lb)
F01-48x1400	0150-5474	1440 mm (56.7 in)	16.71 kg (36.84 lb)
F01-48x1610	0150-5475	1650 mm (65,0.4 in)	18.97 kg (41.81 lb)
F01-48x1820	0150-5476	1860 mm (73.2 in)	21.23 kg (46.81 lb)
F01-48x2000	0150-5477	2040 mm (80.3 in)	23.18 kg (51.09 lb)
F01-48x2210	0150-5478	2250 mm (88,6 in)	25.44 kg (56.09 lb)
F01-48x2450	0150-5478	2490 mm (98.0 in)	28.03 kg (61.79 lb)

Mass including end-plates, profile rail and slider (without stator and adapter plate)

Moving masses of F01-48 guides

Stator PS01-48x240F-C , Flange PF03-48x226 and carrier kit F01-48/FWK-F: 4.90 kg (10.8 lb)

Stator PS01-48x360F-C, Flange PF03-48x346 and carrier kit F01-48/FWK-F: 6.25 kg (13.8 lb)

Drive Setup

The best way to setup a F-Guide together with a LinMot drive is to follow the wizard of the LinMot-Talk software. Detailed information about this wizard can be found in the manuals about the drives. Please note the following screen shots of the wizard which may help to answer some questions

Wizard LinMot-Talk Software

Select the right stator and slider length

(Note: F01-37Sx1600-F relates to a slider PL01-20x1600/1540-HP
stator selection: see label on the stator)

Select 'regular' for Slider mounting direction (comment: in this kind of application the slider direction is not important).

Step 1/8: Actuator Selection

Actuator Data File: PS01-37Sx60-HP-N-AGI.adp

Stator: PS01-37Sx60-HP-N-AGI

Slider: PL01-20x1600/1540-HP (L: 1600mm; D: 20mm)

The slider can be identified by its length.

Slider Mounting Direction: Regular

The sliders are not symmetric. The value of ZP (Zero Position) depends on the mounting direction relative to the stator. Therefore the available stroke range changes with the mounting direction.

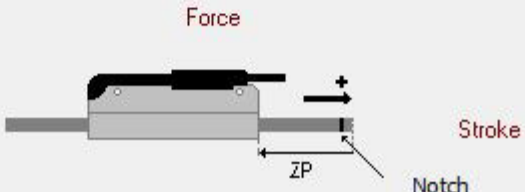

The diagram illustrates a slider assembly. A horizontal slider is shown with a black actuator on top. A red arrow labeled 'Force' points to the right, indicating the direction of movement. A red arrow labeled 'Stroke' points to the right, indicating the range of motion. A red arrow labeled 'ZP' points to the left, indicating the Zero Position. A red arrow labeled 'Notch' points to a small notch on the slider, indicating its location relative to the Zero Position.

Define Payload

The mass of the carriage-kit is about 465 g. The friction is about 7 N. In gantry design, the friction may be higher.



Step 4/8: Feed Forward Parameters

Mechanical Layout
Moving Part of Motor:
Orientation Angle (-90°..+90°): °

Moving Mass
Stator: g
Additional Load Mass: g

Friction Forces
Dry Friction: N
Viscous Friction: N/(m/s)

MagSpring (or other constant force)
External Constant Force: N
Force Direction:



PID Controller

See recommended values to start (the values are higher than normal motor without F-guide) Increase the values if needed. If the payload is high, then increase the D-Filter time as well. (Default D-Filter time = 400 us).

Step 5/8: PID Position Controller

PID Position Controller Setting

P Gain: A/mm (P=2.5, D=4, I=0)
D Gain: A/(m/s) (P=6.2, D=10, I=0)
I Gain: A/(mm*s)
D Filter Time: us

Noise Filter:
Dead Band: mm Enable Noise Filter

Homing

Measure the distance B, which is the distance between the carriage and the end-plate, if the carriage is at the other end of the guide.

Step 7/8: Homing II

Distance from Stator End to Slider End at the Home Position

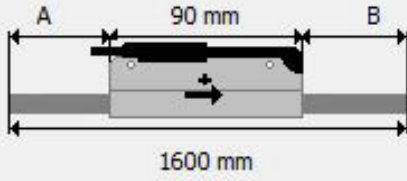

Distance A: mm

Distance B: mm

Step 8/8: Homing III

Definition of the Application Reference System

Home Position (HP): mm

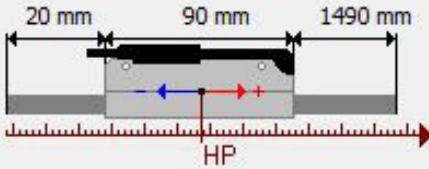

Move to the Initial Position at the End of the Homing Procedure

Initial Position (IP): mm

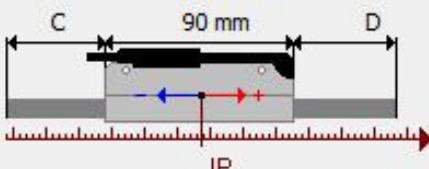

Full length of stroke

To use the full length of the mechanical stroke on a F01-37S guide it is necessary to switch off the 'Maximal Position' error.

The screenshot shows the 'Errors & Warnings' configuration window in the LinMot software. The window title is 'False'. The table below lists various error parameters and their current states.

Name	Value	Raw Data	UPID	Type
Logic Supply Voltage Too Low	True	1h	157Ch	Bool
Logic Supply Voltage Too High	True	1h	157Dh	Bool
Motor Supply Voltage Too Low	True	1h	157Eh	Bool
Motor Supply Voltage Too High	True	1h	157Fh	Bool
Motor Short Time Overload	True	1h	1580h	Bool
Motor Temp Sensor	True	1h	1581h	Bool
PTC Temp Sensor	True	1h	1582h	Bool
Motor Slider Missing	True	1h	1584h	Bool
Motor Hall Signals Missing	True	1h	1585h	Bool
External Position Sensor	True	1h	1586h	Bool
Position Lag Always	True	1h	1587h	Bool
Position Lag Standing	True	1h	1588h	Bool
Minimal Position	True	1h	158Ch	Bool
Maximal Position	False	0h	158Dh	Bool
RR Check	True	1h	158Eh	Bool
RR Hot Calculated	True	1h	158Fh	Bool
Check Stator Type	True	1h	1590h	Bool

Or change the minimal and maximal position

The screenshot shows the 'Position Limits' configuration window in the LinMot software. The window title is 'LinMot-Talk 6.2'. The table below lists the minimal and maximal position settings.

Name	Value	Raw Data	UPID	Type
Minimal Position	-100 mm	FFF0BDC0h	146Eh	SInt32
Maximal Position	100 mm	000F4240h	146Fh	SInt32

Order Information for Guide F01-37S

The guides will be delivered pre-assembled. See section 'Assembling of components' if additional stators or parts must be installed later. Go step by step though the following order procedure:

1. Step: Select F01-37S guide

Description	Part-No	Length total	Stroke w. PS01-37Sx60*	Stroke w. PS01-37Sx120*
F01-37Sx300	0150-5453	330 mm	200 mm (7.8")	140 mm (5.5")
F01-37Sx400	0150-5449	430 mm	300 mm (11.8")	240 mm (9.4")
F01-37Sx500	0150-5450	530 mm	400 mm (15.7")	340 mm (13.3")
F01-37Sx600	0150-5424	630 mm	500 mm (19.6")	440 mm (17.3")
F01-37Sx800	0150-5425	830 mm	700 mm (27.5")	640 mm (25.1")
F01-37Sx1000	0150-5426	1030 mm	900 mm (35.4")	840 mm (33")
F01-37Sx1200	0150-5427	1230 mm	1100 mm (43.3")	1040 mm (40.9")
F01-37Sx1400-F	0150-5428	1430 mm	1300 mm (51.1")	1240 mm (48.8")
F01-37Sx1600-F	0150-5429	1630 mm	1500 mm (59")	1440 mm (56.6")
F01-37Sx2000-F	0150-5430	2030 mm	1900 mm (74.7")	1840 mm (72.4")

*Stroke tolerance: +0 mm/ -5 mm
Guide including end-plates and profile rail

2. Step: Select Slider

Description	Part-No	For Guide
PL01-20x300/240-HP	0150-1506	F01-37Sx300
PL01-20x400/340-HP	0150-1508	F01-37Sx400
PL01-20x500/440-HP	0150-1509	F01-37Sx500
PL01-20x600/540-HP	0150-1510	F01-37Sx600
PL01-20x800/740-HP	0150-1512	F01-37Sx800
PL01-20x1000/940-HP	0150-1514	F01-37Sx1000
PL01-20x1200/1140-HP	0150-1515	F01-37Sx1200
PL01-20x1400/1340-HP	0150-1516	F01-37Sx1400-F
PL01-20x1600/1540-HP	0150-1517	F01-37Sx1600-F
PL01-20x2000/1940-HP	0150-1543	F01-37Sx2000-F

One slider is necessary for each guide.

3. Step: Select type and quantity of Carriage-Kit

Description	Part-No	Description
F01-37S/FWK	0150-5480	Carriage and ground plate for guides <1400 mm
F01-37S/FWK-F	0150-5481	Carriage and ground plate for guides >= 1400 mm

It is possible to run more than one carriage on one guide. Kit includes carriage, adapter plate and all screws to mount stator and carriage.

Note: F01-37S guides equal or longer than 1400 mm need F01-37S/FWK-F carriage kits. The ground plate of the F01-37S/FWK-F is 7 mm thicker than the ground plate of the F01-37S/FWK. That means all mounted parts are moved by 7 mm. See dimensions in brackets on the drawings.

Spare part: Carriage (from SKF) without adapter plate: LLTHC 15 U-T2 P5 Part-No 0150-5265

4. Step: Select type and quantity of Stator

Description	Part-No	
PS01-37Sx60-HP-N-AGI	0150-2549	37 series HP stator with N connector (IP50)
PS01-37Sx120F-HP-N-AGI	0150-2550	37 series HP stator with N connector (IP50)

It is possible to run more than one stator on one guide. Each stator needs its own carriage-kit.

If different stators are ordered, it is necessary to note the assembling sequence of the stators (from left to right) on the guide, viewing angle from the site with the trailing chain (see pictures Design 'cable to the left' or 'cable to the right').

(e.g. 3 stators in the sequence (from left to right): PS01-37Sx60 / PS01-37Sx60 / PS01-37Sx120)

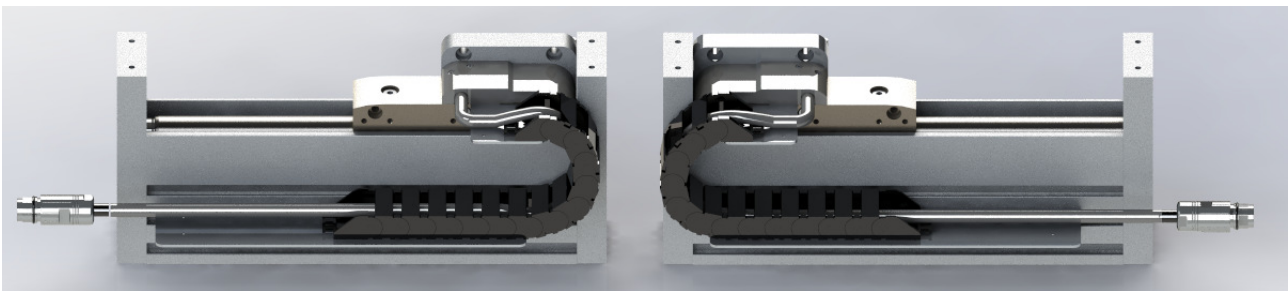

Design: 'cable to the left'

Design: 'cable to the right' (default)

If not mentioned differently, F-guides will be assembled 'cable to the right'.

5. Step: Select Trailing chain kit or trailing chain (optional)

5.1 Trailing chain kit

Description	Part-No	For Guide	Length of trailing chain
F01-TC300	0150-5457	F01-37Sx300	Ca 200 mm
F01-TC400	0150-5456	F01-37Sx400	Ca 300 mm
F01-TC500	0150-5455	F01-37Sx500	Ca 400 mm
F01-TC600	0150-5439	F01-37Sx600	Ca 500 mm
F01-TC800	0150-5440	F01-37Sx800	Ca 600 mm
F01-TC1000	0150-5441	F01-37Sx1000	Ca 700 mm
F01-TC1200	0150-5442	F01-37Sx1200	Ca 800 mm
F01-TC1400	0150-5443	F01-37Sx1400-F	Ca 900 mm
F01-TC1600	0150-5444	F01-37Sx1600-F	Ca 1000 mm
F01-TC2000	0150-5445	F01-37Sx2000-F	Ca 1200 mm

Includes trailing chain and brackets to mount the trailing chain to the stator and the guide. (The kit can not be used for multiple carriage applications).

5.2 Trailing chain

Description	Part-No	For Guide	Length of trailing chain
F01h-KS300	0160-0983	F01-37Sx300	Ca 200 mm
F01h-KS400	0160-0981	F01-37Sx400	Ca 300 mm
F01h-KS500	0160-0982	F01-37Sx500	Ca 400 mm
F01h-KS600	0160-0971	F01-37Sx600	Ca 500 mm
F01h-KS800	0160-0972	F01-37Sx800	Ca 600 mm
F01h-KS1000	0160-0973	F01-37Sx1000	Ca 700 mm
F01h-KS1200	0160-0974	F01-37Sx1200	Ca 800 mm
F01h-KS1400	0160-0975	F01-37Sx1400-F	Ca 900 mm
F01h-KS1600	0160-0976	F01-37Sx1600-F	Ca 1000 mm
F01h-KS2000	0160-0977	F01-37Sx2000-F	Ca 1200 mm

Only trailing chain without any brackets

6. Step: Select Trailing chain cables (high-flex cable)

Description	Part-No	Description	For Motor
KS03-R/N-1.5	0150-3563	Trailing chain cable 1.5 m with R/N-connector	PS01-37Sx60 or PS01-37Sx120
KS03-R/N-2	0150-3564	Trailing chain cable 2 m with R/N-connector	PS01-37Sx60 or PS01-37Sx120
KS03-R/N-3	0150-3565	Trailing chain cable 3 m with R/N-connector	PS01-37Sx60 or PS01-37Sx120
KS03-R/R-1.5	0150-3566	Trailing chain cable 1.5 m with R/R-connector	PR01-52x40-R/37x120F-...
KS03-R/R-2	0150-3567	Trailing chain cable 2 m with R/R-connector	PR01-52x40-R/37x120F-...
KS03-R/R-3	0150-3568	Trailing chain cable 3 m with R/R-connector	PR01-52x40-R/37x120F-...
KS03-C/C-1.5	0150-3569	Trailing chain cable 1.5 m with C/C-connector	PR01-52x40-R/37x120F-..
KS03-C/C-2	0150-3570	Trailing chain cable 2 m with C/C-connector	PR01-52x40-R/37x120F-..
KS03-C/C-3	0150-3571	Trailing chain cable 3 m with C/C-connector	PR01-52x40-R/37x120F-..

The KS03 trailing chain cable should be as short as possible. Use an extension cable for the connection between the trailing chain cable and the drive.

- PS01-37S stators which are built into the F01-37S guides need KS03-R/N-... cables
- The rotary part of the PR01-52x40-R/37x120F-...motors or the PS01-23x ...-R stators need KS03-R/R-... cables
- The lineary part of the PR01-52x40-R/37x120F-...motors or PS01-37x ... -C stators need KS03-C/C-... cables

7. Step: External Sensor-Kit (optional)

Description	Part-No	
F01-37S-SK	0150-5446	Identical for all guides, cable length 2m

The external sensor kit includes sensor MS01-1/D Part- No 0150-1840, sensor adapter plate and mounting screws. The magnetic strip must be ordered separately.

8. Step: Magnetic strip (optional)

Description	Part-No	For Guide
F01-MB300	0150-5454	F01-37Sx300
F01-MB400	0150-5451	F01-37Sx400
F01-MB500	0150-5452	F01-37Sx500
F01-MB600	0150-5431	F01-37Sx600
F01-MB800	0150-5432	F01-37Sx800
F01-MB1000	0150-5433	F01-37Sx1000
F01-MB1200	0150-5434	F01-37Sx1200
F01-MB1400	0150-5435	F01-37Sx1400-F
F01-MB1600	0150-5436	F01-37Sx1600-F
F01-MB2000	0150-5437	F01-37Sx2000-F

Only one magnetic strip is needed for several motors with external position sensor kits to run on one guide.

9. Step: Adapter plate for linear rotary motors (optional)

Description	Part-No	For linear rotary motors
F01k-PR01-52	0160-2536	PR01-52x40-R/37x120F-HP-C-80 (-L) PR01-52x60-R/37x120F-HP-C-100 (-L)
F01k-PR01-52x60	0160-2657	PR01-52x60-R/37x120F-HP-C-100 (-L) PR01-52x60-R/37x120F-HP-C-150 (-L)
F01k-PR01-84*	0160-2594	PR01-84x80-C/48x240F-C100 (-L) (-G0x) PR01-84x80-C/48x360F-C100 (-L) (-G0x)

The adapter plates must be mounted to a F01-37S/FWK or F01-37S/FWK-F carriage kit.

10. Step: Nuts for T-Slot (optional)

Description	Part-No	
Nut N8 / M4	0150-2189	Nut for 8 mm slots of F01 guides with M4 thread
Nut N8 / M6	0150-2558	Nut for 8 mm slots of F01 guides with M6 thread

Dimensions see drawings

Order example:

Example 1: F01-37S guide shorter than 1400 mm

pcs	Description	Part-No	comment
1	F01-37Sx800	0150-5425	F01-37S guide 800 mm
1	PL01-20x800/740-HP	0150-1512	Slider
1	F01-37S/FWK	0150-5480	Carriage kit (Guide <1400 mm)
1	PS01-37Sx120F-HP-N-AGI	0150-2550	Stator (linear motor)
1	F01-TC800	0150-5440	Trailing chain kit
1	KS03-R/N-2	0150-3564	Trailing chain cable 2 m

Example 2: F01-37S guide longer than 1400 mm with optional external sensor

pcs	Description	Part-No	comment
1	F01-37Sx1600-F	0150-5429	F01-37S guide 1600 mm
1	PL01-20x1600/1440-HP	0150-1517	Slider
1	F01-37S/FWK-F	0150-5481	Carriage kit (guide >= 1400 mm)
1	PS01-37Sx60-HP-N-AGI	0150-1549	Stator (linear motor)
	"Design: cable to the left"		
1	F01-TC1600	0150-5444	Trailing chain kit
1	KS03-R/N-2	0150-3564	Trailing chain cable 2 m
1	F01-37S-SK	0150-5446	External Sensor kit, cable length 2m
1	F01-MB1600	0150-5436	Magnetic Strip for F01-37Sx1600

Example 3: F01-37S guide longer than 1400 mm with 3 moving stators

pcs	Description	Part-No	comment
1	F01-37Sx1600-F	0150-5429	F01-37S guide 1600 mm
1	PL01-20x1600/1440-HP	0150-1517	Slider
3	F01-37S/FWK-F	0150-5481	Carriage kit (guide >= 1400 mm)
2	PS01-37Sx120F-HP-N-AGI	0150-2550	Stator (linear motor)
1	PS01-37Sx60-HP-N-AGI	0150-1549	Stator (linear motor)
3	KS03-R/N-2	0150-3564	Trailing chain cable 2 m
4	Nut N8 / M6	0150-2558	Nuts for T-Slot to mount the F-Guide

Sequence of stators: PS01-37Sx120F / PS01-37Sx120F /PS01-37Sx60F

Order Information for Guide F01-48

The guides will be delivered pre-assembled. See section 'Assembling of components' if additional stators or parts must be installed later. Go step by step though the following order procedure:

1. Step: Select F01-48 guide

Description	Part-No	Length total	Stroke w.ith PS01-48x240F-C	Stroke w.ith PS01-48x360F-C
F01-48x500	0150-5469	540 mm (21.3 in)	200 mm (7.8")	80 mm (3.1")
F01-48x620	0150-5470	660 mm (26.0 in)	320 mm (12.5")	200 mm (7.8")
F01-48x800	0150-5471	840 mm (33.1 in)	500 mm (19.6")	380 mm (14.9")
F01-48x1010	0150-5472	1050 mm (41.3 in)	710 mm (27.9")	590 mm (23.2")
F01-48x1220	0150-5473	1260 mm (49,6 in)	920 mm (36.2')	800 mm (31.4")
F01-48x1400	0150-5474	1440 mm (56.7 in)	1100 mm (43.3")	980 mm (38.5")
F01-48x1610	0150-5475	1650 mm (65,0.4 in)	1310 mm (51.5")	1190 mm (46.8")
F01-48x1820	0150-5476	1860 mm (73.2 in)	1520 mm (59.8")	1400 mm (55.1")
F01-48x2000	0150-5477	2040 mm (80.3 in)	1700 mm (66.9")	1580 mm (62.2")
F01-48x2210	0150-5478	2250 mm (88,6 in)	1960 mm (77.1")	Not available
F01-48x2450	0150-5478	2490 mm (98.0 in)	2150 mm (84.6")	Not available

2. Step: Select Slider

Description	Part-No	For Guide
PL01-28x500/420	0150-1382	F01-48x500
PL01-28x620/540	0150-1383	F01-48x620
PL01-28x800/720	0150-1385	F01-48x800
PL01-28x1010/930	0150-1387	F01-48x1010
PL01-28x1220/1140	0150-1388	F01-48x1220
PL01-28x1400/1320	0150-1389	F01-48x1400
PL01-28x1610/1530	0150-1390	F01-48x1610
PL01-28x1820/1740	0150-1395	F01-48x1820
PL01-28x2000/1920	0150-1396	F01-48x2000
PL01-28x2210/2130	0150-1397	F01-48x2210
PL01-28x2450/2370	0150-1398	F01-48x2450

One slider is necessary for each guide.

3. Step: Select quantity of Carriage-Kit

Description	Part-No	Description
F01-48/FWK-F	0150-5488	Kit includes 2 carriages and ground plate

It is possible to run more than one carriage on one guide. Kit includes 2 carriages, ground plate and all screws to mount stator, flange and carriage.

Spare part: Carriage (from SKF) without ground plate:
LLTHC 15 U-T2 P5 Part-No 0150-5265 (2 pcs necessary)

4. Step: Select type and quantity of Stators and Flanges

Description	Part-No	Description
PS01-48x240F-C PF03-48x226	0150-1220 0150-5489	48 series HP stator with C connector Flange for PS01-48x240F-C and F01-48 Guide
PS01-48x360F-C PF03-48x346	0150-1269 0150-5490	48 series HP stator with C connector Flange for PS01-48x360F-C and F01-48 Guide

Each stator needs a flange to be mounted on an a ground plate F01-48/FWK-F.

It is possible to run more than one stator on one guide. Each stator needs its own carriage-kit.

If different stators are ordered, it is necessary to note the assembling sequence of the stators (from left to right) on the guide, viewing angle from the site with the trailing chain (see pictures Design 'cable to the left' or 'cable to the right').

(e.g. 3 stators in the sequence (from left to right): PS01-48x240F / PS01-48x240F / PS01-48x360F)

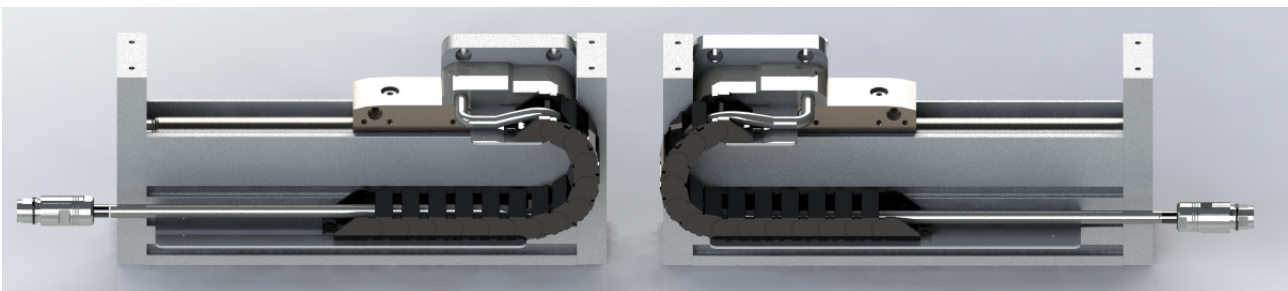

Design: 'cable to the left'

Design: 'cable to the right' (default)

If not mentioned differently, F-guides will be assembled 'cable to the right'.

5. Step: Select Trailing chain kit or trailing chain (optional)

5.1 Trailing chain kit

Description	Part-No	For Guide	Length of trailing chain
F01-TC500	0150-5455	F01-48x500	Ca 400 mm
F01-TC600	0150-5439	F01-48x620	Ca 500 mm
F01-TC800	0150-5440	F01-48x800	Ca 600 mm
F01-TC1000	0150-5441	F01-48x1010	Ca 700 mm
F01-TC1200	0150-5442	F01-48x1220	Ca 800 mm
F01-TC1400	0150-5443	F01-48x1400	Ca 900 mm
F01-TC1600	0150-5444	F01-48x1610	Ca 1000 mm
F01-TC1800	0150-5492	F01-48x1820	Ca 1100 mm
F01-TC2000	0150-5445	F01-48x2000	Ca 1200 mm
F01-TC2200	0150-5493	F01-48x2210	Ca 1300 mm
F01-TC2400	0150-5494	F01-48x2450	Ca 1400 mm

Includes trailing chain and brackets to mount the trailing chain to the stator and the guide. (The kit can not be used for multiple carriage applications).

5.2 Trailing chain

Description	Part-No	For Guide	Length of trailing chain
F01h-KS500	0160-0982	F01-48x500	Ca 400 mm
F01h-KS600	0160-0971	F01-48x620	Ca 500 mm
F01h-KS800	0160-0972	F01-48x800	Ca 600 mm
F01h-KS1000	0160-0973	F01-48x1010	Ca 700 mm
F01h-KS1200	0160-0974	F01-48x1220	Ca 800 mm
F01h-KS1400	0160-0975	F01-48x1400	Ca 900 mm
F01h-KS1600	0160-0976	F01-48x1610	Ca 1000 mm
F01h-KS1800	0160-1011	F01-48x1820	Ca 1100 mm
F01h-KS2000	0160-0977	F01-48x2000	Ca 1200 mm
F01h-KS2200	0160-1012	F01-48x2210	Ca 1300 mm
F01h-KS2400	0160-1013	F01-48x2450	Ca 1400 mm

Only trailing chain without any brackets

6. Step: Select Trailing chain cables (high-flex cable)

PS01-48x240F-C and PS01-48x360F-C should be used with KS10 trailing chain (high flex) cables.

Description	Part-No	Description	For Drives
KS10-C/C-2	0150-1816	Trailing chain cable 2 m with C/C-connector	Extension cable
KS10-C/C-4	0150-1817	Trailing chain cable 4 m with C/C-connector	Extension cable
KS10-W/C-4	0150-1807	Trailing chain cable W/C, 4 m	E1100, E1200 series
KS10-W/C-5	0150-1860	Trailing chain cable W/C, 5 m	E1100, E1200 series
KS10-W/C-6	0150-1858	Trailing chain cable W/C, 6 m	E1100, E1200 series
KS10-W/C-8	0150-1808	Trailing chain cable W/C, 8 m	E1100, E1200 series
KS10-Y/C-4	0150-2439	Trailing chain cable Y/C, 4 m	C1100, C1200 series
KS10-Y/C-6	0150-2440	Trailing chain cable Y/C, 4 m	C1100, C1200 series
KS10-Y/C-8	0150-2441	Trailing chain cable Y/C, 8 m	C1100, C1200 series

See LinMot databook or e-catalogue for more cable options.

7. Step: External Sensor-Kit (optional)

Description	Part-No	
F01-37S-SK	0150-5446	Identical for all guides, cable length 2m

The external sensor kit includes sensor MS01-1/D Part- No 0150-1840, sensor adapter plate and mounting screws. The magnetic strip must be ordered separately.

8. Step: Magnetic strip (optional)

Description	Part-No	For Guide
F01-MB500	0150-5452	F01-48x500
F01-MB620	0150-5461	F01-48x620
F01-MB800	0150-5432	F01-48x800
F01-MB1010	0150-5462	F01-48x1010
F01-MB1220	0150-5463	F01-48x1220
F01-MB1400	0150-5465	F01-48x1400
F01-MB1610	0150-5464	F01-48x1610
F01-MB1820	0150-5465	F01-48x1820
F01-MB2000	0150-5437	F01-48x2000
F01-MB2210	0150-5467	F01-48x2210
F01-MB2450	0150-5468	F01-48x2450

9. Step: Adapter plate for linear rotary motors (optional)

Description	Part-No	For linear rotary motors
F01k-PR01-52	0160-2536	PR01-52x40-R/37x120F-HP-C-80 (-L) PR01-52x60-R/37x120F-HP-C-100 (-L)
F01k-PR01-52x60	0160-2657	PR01-52x60-R/37x120F-HP-C-100 (-L) PR01-52x60-R/37x120F-HP-C-150 (-L)
F01k-PR01-84	0160-2594	PR01-84x80-C/48x240F-C100 (-L) (-G0x) PR01-84x80-C/48x360F-C100 (-L) (-G0x)

The adapter plates must be mounted to a F01-48/FWK-F carriage kit.

Note: H- and B-guides can directly be mounted to the F01-48/FWK-F carriage kit.

10. Step: Nuts for T-Slot (optional)

Description	Part-No	
Nut N8 / M4	0150-2189	Nut for 8 mm slots of F01 guides with M4 thread
Nut N8 / M6	0150-2558	Nut for 8 mm slots of F01 guides with M6 thread

Dimensions see drawings

Gantry Design

If requested, Gantry Designs will be delivered pre-assembled. Please note direction of the cables

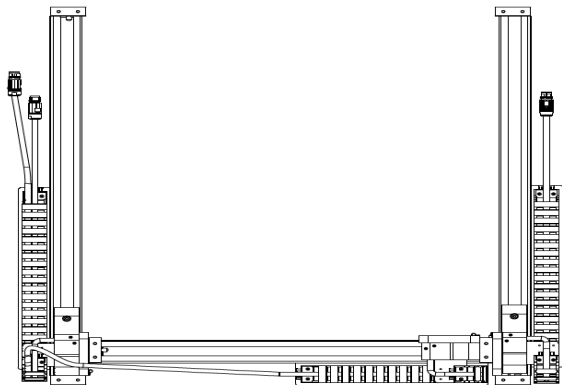

Design "left" (cable to the left)

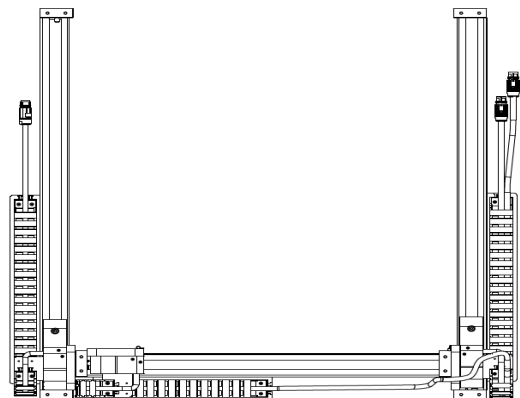

Design "right" (cable to the right):

Assembly of Gantry design

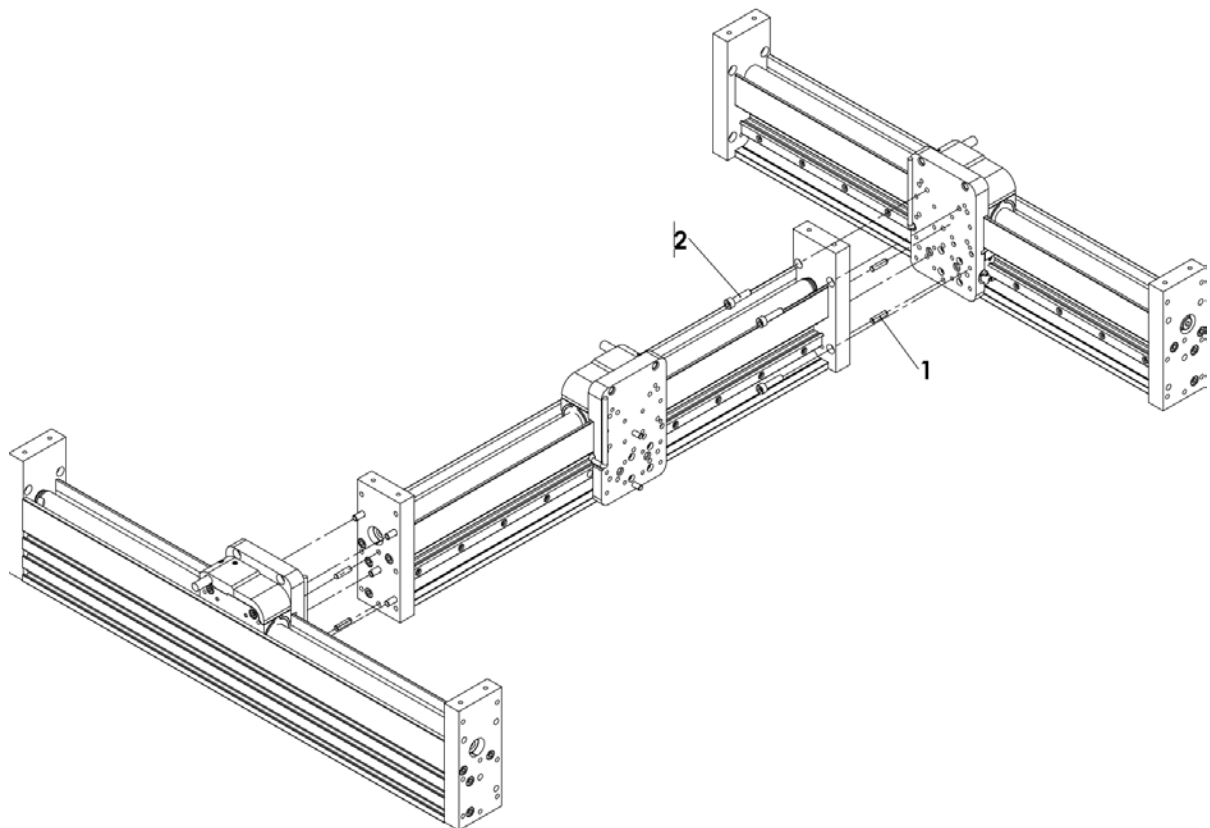

1. Pins 5x20 mm (2 pcs on both side)
2. Screws M6x30 (4 pcs on both side)

Combination of F01-48 and F01-37S guides

F01-37 guides can directly be mounted to the bigger F01-48 guides. It is also possible to realize semi gantry constructions as shown below.

Semi gantry design

Semi gantry designs are very cost effective solutions. It is possible to realize a semi gantry without an additional X-guide as long as the F01-37 guide is short (max 400 mm) and some vibrations are acceptable. However in high performance applications, heavy load conditions, or long Y-axis strokes an additional X-guide must be considered.



Semi gantry design: F01-48 guide (X-axis), short F01-37 guide (y-axis), H01-23 guide (Z-axle)

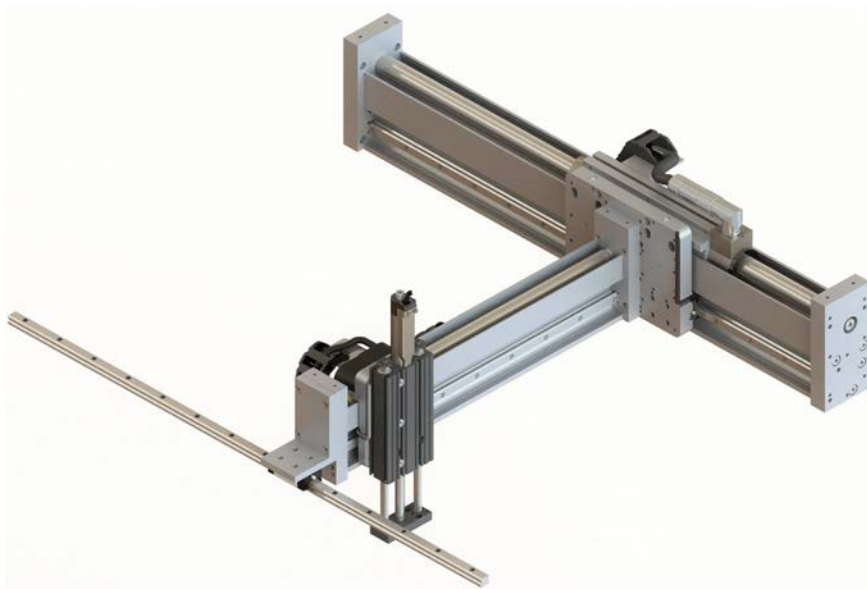

Semi gantry design: F01-48 guide (X-axis), F01-37S guide (Y-Axis) with additional X-guide to eliminate vibrations, H01-23 guide (Z-axis)

Multiple carrier design

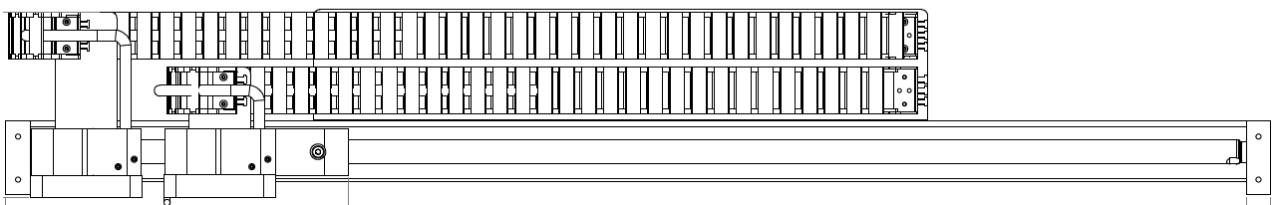
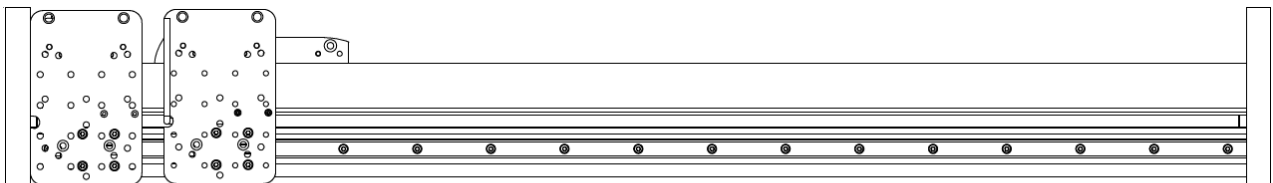

The picture shows one possibility to arrange the trailing chains for a multiple carrier design. Because of the huge number of design variations the adapters must be produced by the customer.

Mounting instructions

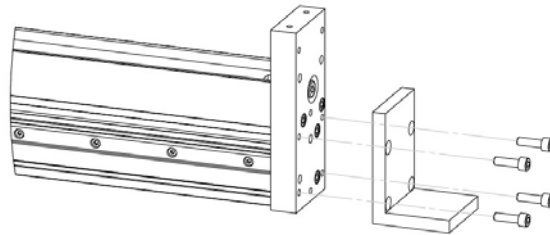
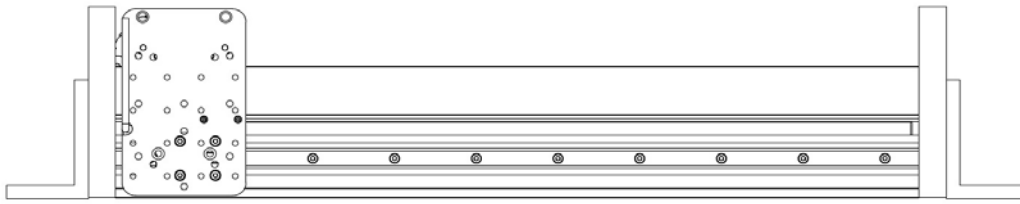

Mounting by side plates

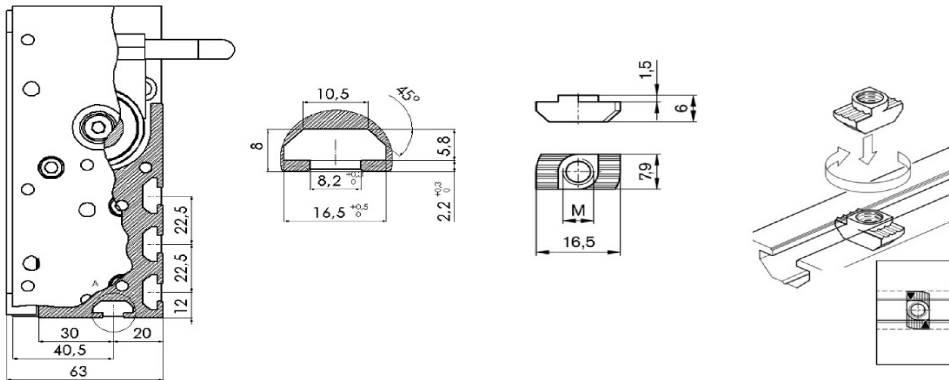
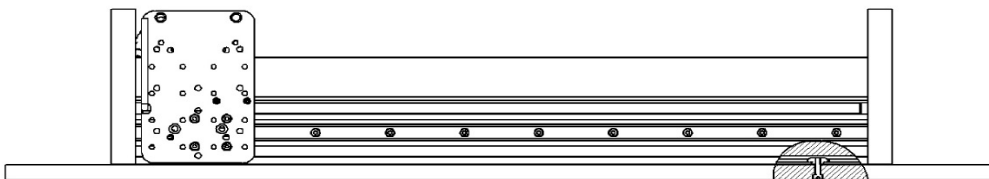

Mounting 'from the bottom' with nuts and T-slots. Orientation: "Slider to the top"

Note: F01-37S guides, which are 1400 mm or longer, must be mounted with the "slider to the top", as shown in the drawings. Shorter guides can be mounted in every direction. In this case the user has to mount the trailing chain cables corresponding.

Assembling Instructions

F01-37 guides will normally be delivered completely assembled. In case of replacements or if additional carriages/motors should be installed the following installation guides must be considered. Use always threadlocker.

Direction of the motor cable

According to the application and trailing chain installation of the motor cable, the outlet must be selected. See installation guide of the short stators PS01-37Sx... for details.

Assembly and disassembly of the motors and carriages

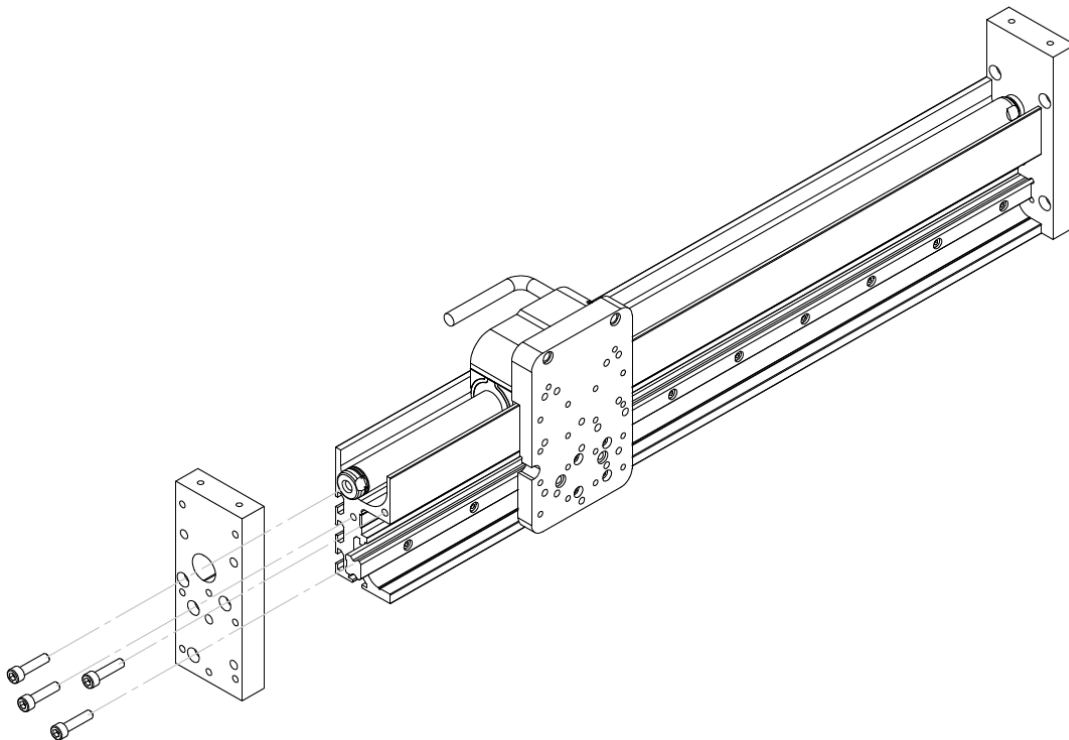

Disassemble the end plate from the side where the slider is in the loose bearing (not fixed by the screw). Support the slider with non-iron parts so that it can not fall into the guide and remove the end plate.

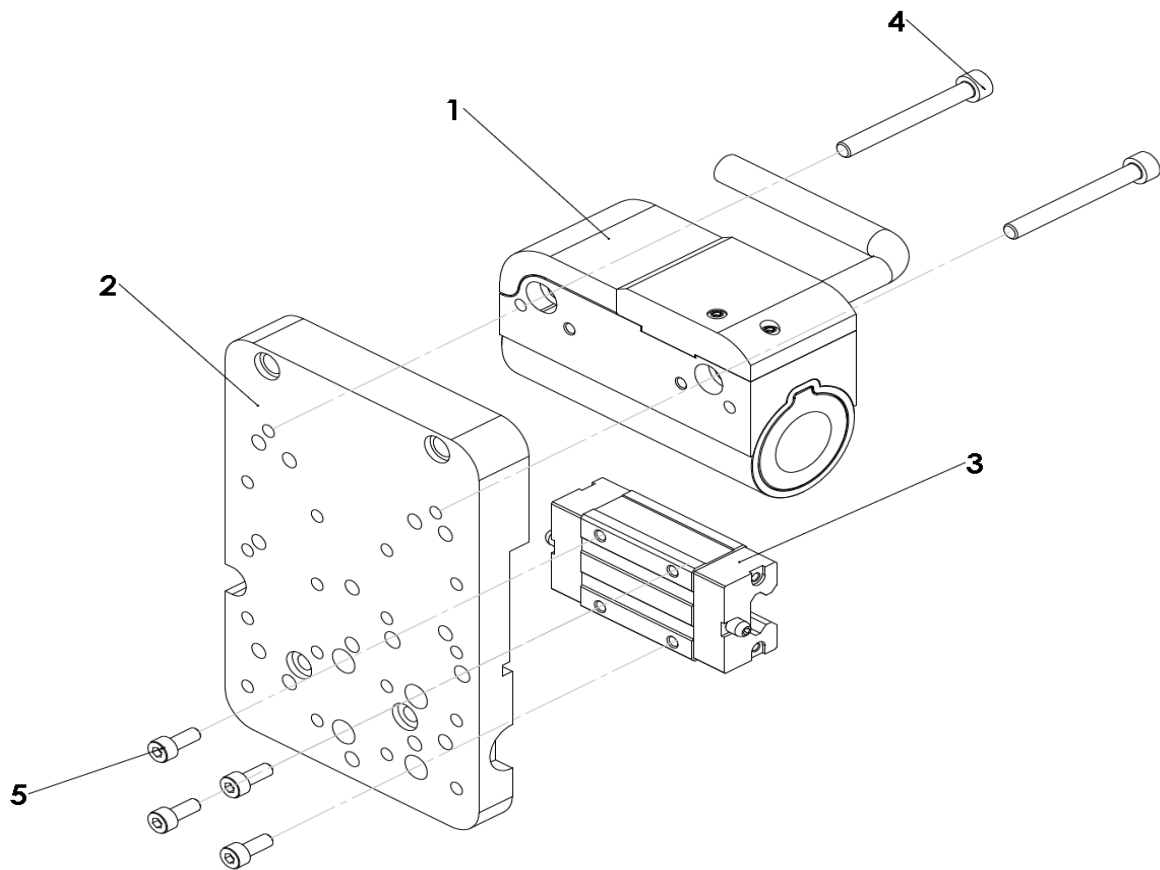

1. Move the carriage (3) carefully on the profile rail. Mount adapter plate (2) with screws 5 (M4x8) to the carriage. Make sure that the adapter plate (2) is aligned to the profile rail (use 90° bracket) ! Now tighten screws 5.
Mount stator (1) with screws 4 (M5x45) to the adapter plate (2). (The direction of the stator may depend on the needs of the application).
2. Assemble end plate with screws M6x25
3. Loosen screws 4 to align the stator. Move the carriage unit to the loosen bearing side of the guide. Then tighten screws 4 .
4. Move carriage unit to the side with the fixed bearing and loose screws 4 once again if the carriage shows heavy friction. Re-tighten screws 4.
5. Move the carriage unit to the side with the loose bearing, If the carriage shows heavy friction then loose screws from the end plate and tighten screws again. Loosen screws 4 to align the stator. Move the carriage unit to the loose bearing side of the guide. Then tighten screws 4
6. Move the carriage unit to the side with the fixed bearing, If the carriage shows still heavy friction then loosen the M8 screw of the slider and tight it again. Then start alignment process as written before again (steps 3 to 6.)

Assembly of the slider

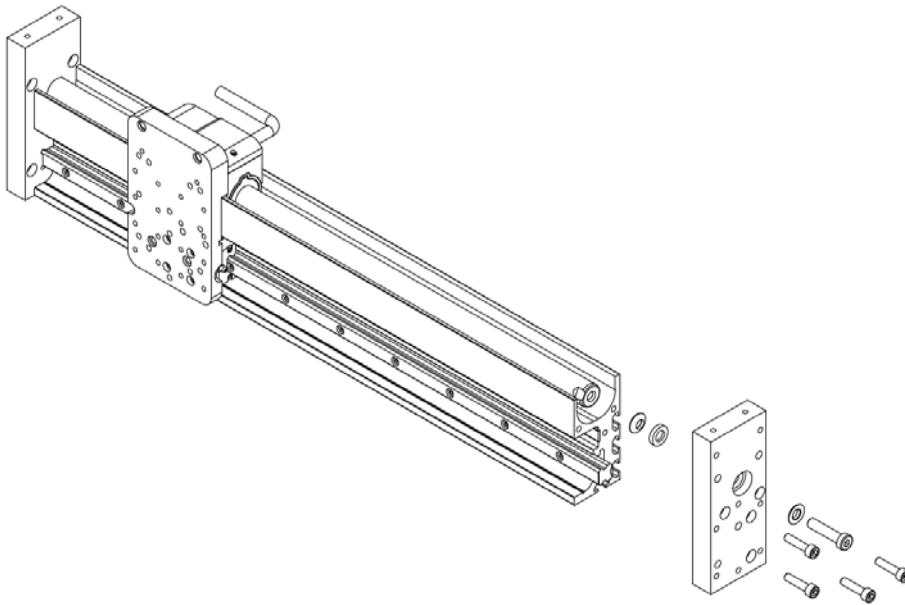

Select the end of the slider without the notches and fasten slider with screw M8x35 to the end plate. Mount spherical washers on both side of the end plate. Use conical washer on the side of the slider.

Assembly of the railway

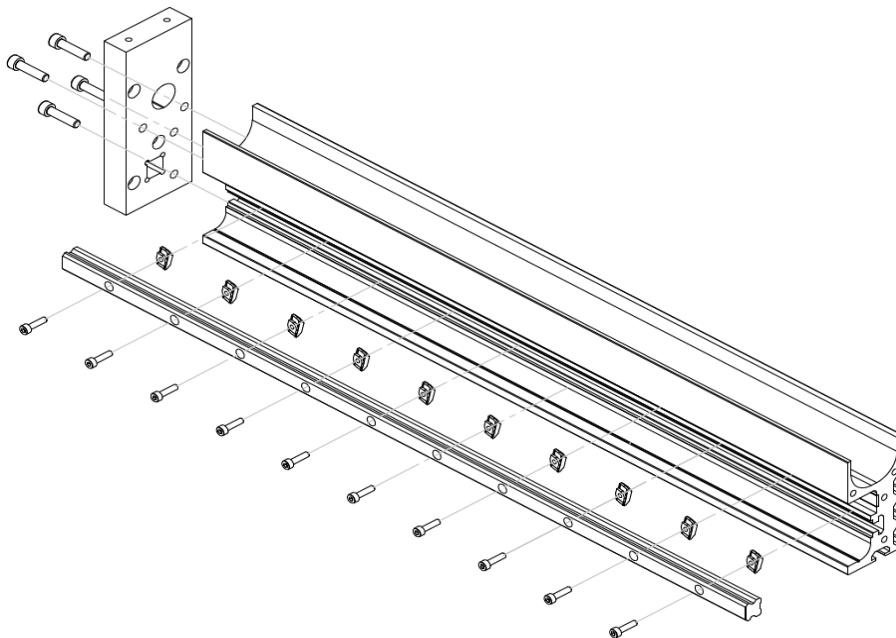

Use M4x16 screws and nuts to mount the railway to the profile. Align the railway with the profile. Every position for the screws must be used. The end plates are mounted with M6x25 screws.

Assembly of Trailing Chain Kit

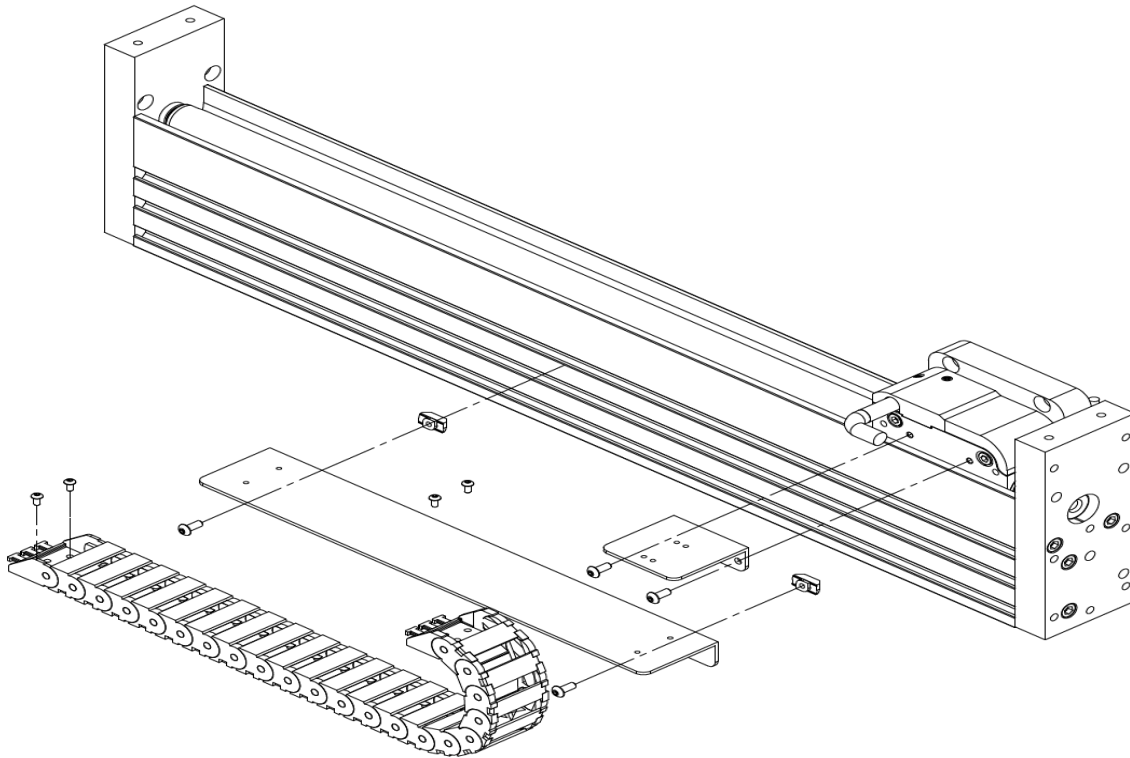

Mount the L-profile with M4x10 screws and nuts into the middle or lower slot of the guide depending on the bend radius of the high flex cables. Mount the adapter to the stator with 2 screws M4x5. Fix the trailing chain to the L-profile and the adapter with 4 screws M3x6.



Trailing chains are located in parallel (side by side) for multiple motor applications. Adapters and L-profiles for the chains are depending on the application and must be designed by the user.

Assembly of an external sensor-kit

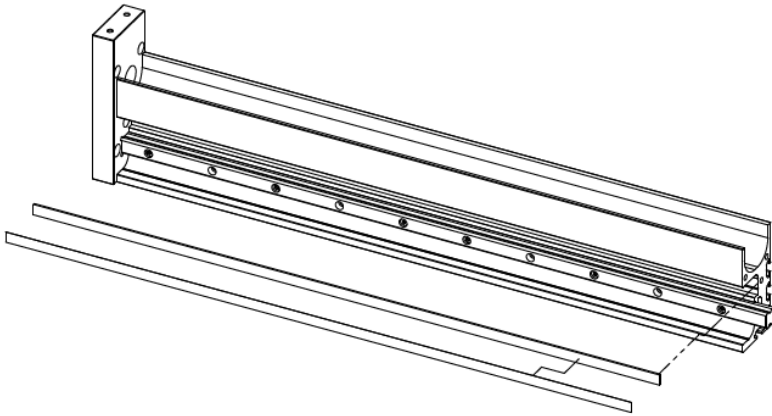

- 1.) Clean slot on guide profile
- 2.) Stick magnetic strip with cover into the slot
- 3.) Screw sensor with 2 pcs M3x12 on the adapter plate and adjust distance according to the installation guide for the external sensor.

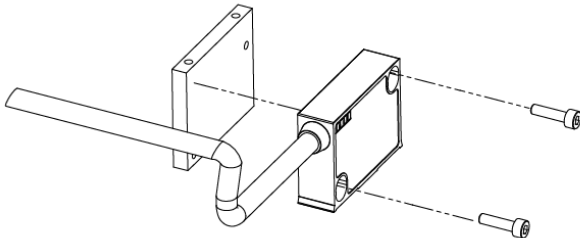

- 4.) Install adapter with sensor to the backside of the adapter plate (2 pcs M2.5x8) . Secure sensor cable with bracket to the adapter plate (M3x6).

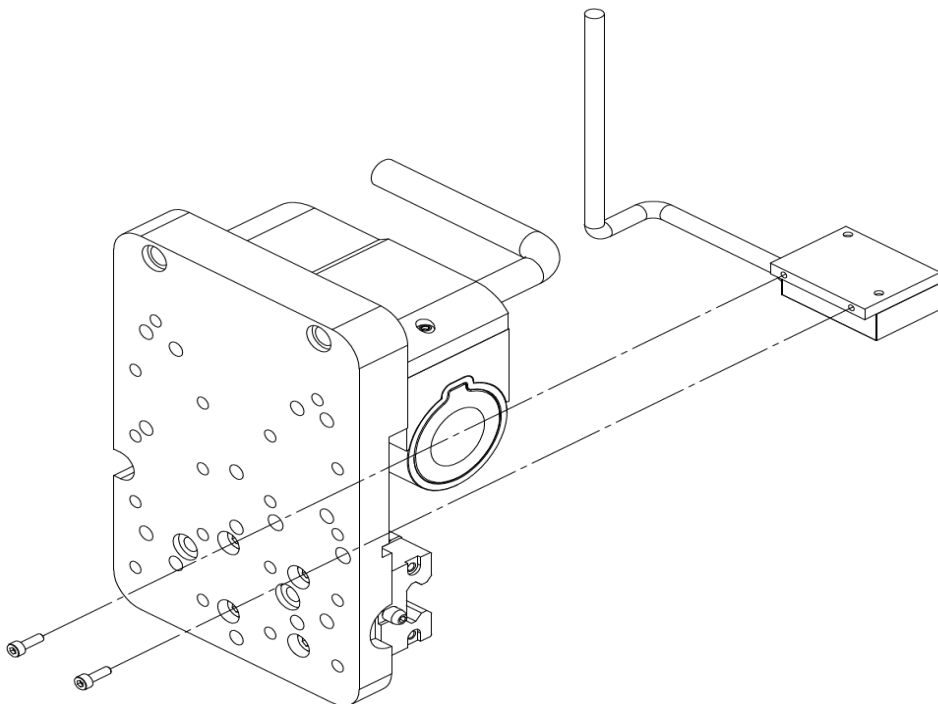

Bearing load on F01-37S guides

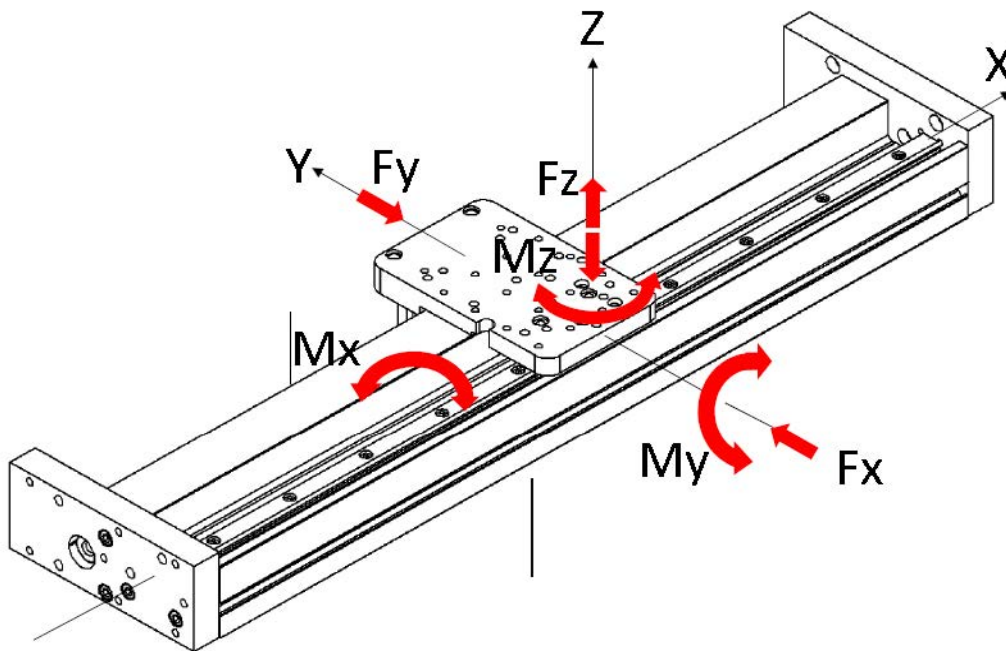

Static and dynamic bearing loads F_x und F_y

F01-37S guide

SKF profile rail guide: LLT Size 15 profil rail, carriage LLTHC 15 U-T2 P5

See SKF Manual 'Profile rail guides LLT' (www.SKF.com, document: 12942_1_EN_LLТ_2013.pdf) for additional information about lifetime and maintenance. (LLT Size 15 profil rail, carriage LLTHC 15 U-T2 P5)

Load capacity static: $C_0 := 15,400 \text{ N}$

Load capacity dynamic: $C := 8,400 \text{ N}$

The static and dynamic load bearing will normally not be calculated because a reasonable application will be limited by the motor performance and not the load bearing. To calculate the application data we recommend to use the analyzing program LinMot Designer (see Downloads sector on www.LinMot.com)

If the application shows massive static forces, e.g. if a press is punching on parts which are moved on the guide, then the load bearing must be evaluated carefully.

Calculation of the static load bearing F_x and F_y

To calculate the static bearing load you need the factor f_a for the load condition, the desired static safety factor s_0 , and the resulting force F_{res} . The static load of the F01-37S guide is: $C_0 := 15,400 \text{ N}$

Load condition f_d

Max velocity $v_{\max} < 2 \text{ m/s}$: $f_d = 1 \dots 1.5$
Max acceleration $v_{\max} > 2 \text{ m/s}$: $f_d = 1.5 \dots 3$

static safety factor s_0

normal conditions: $s_0 \geq 2$
medium vibration or impact loads: $s_0 = 3-5$
high vibration or impact loads: $s_0 > 5$

resulting Force F_{res}

$$F_{\text{res}} := \text{abs}(F_x) + \text{abs}(F_y)$$

Evaluation of the static load

$$F_{\text{res}} := \text{abs}(F_x) + \text{abs}(F_y) < C_0 / (f_d * s_0)$$

Sample:

C_0 of the F01-37S guide: $C_0 := 15,400 \text{ N}$
Load in y-direction: $F_{\text{res}} := \text{abs}(F_y)$
Max velocity: $v_{\max} = 1.5 \text{ m/s} \rightarrow f_d = 1$
High vibration or impact loads: $s_0 := 5$

$$F_{\text{res}} := \text{abs}(F_x) + \text{abs}(F_y) < C_0 / (f_d * s_0)$$
$$:= \text{abs}(F_y) := 15,400 \text{ N} / (1 * 5) := 3,080 \text{ N}$$

Note:

The static load bearing must normally not be calculated because it is impossible to move a payload of 308 kg with a P01-37S motor. However impacts from presses must be considered.

Static and dynamic moment load M_{xyz}

F01-37S guide

Direction of moment	Static	Dynamic
M_x	103 Nm (75.9 lb ft)	56 Nm (41.3 lb ft)
M_y	90 Nm (66.3 lb ft)	49 Nm (36.1 lb ft)
M_z	90 Nm (66.3 lb ft)	49 Nm (36.1 lb ft)

To minimize the moment load it is recommended to mount a payload as close as possible to the carriage. In case of overhanging loads the moments must be reviewed.

See SKF Manual 'Profile rail guides LLT' (www.SKF.com, document: 12942_1_EN_LL2013.pdf) for additional information about lifetime and maintenance. (LLT Size 15 profil rail, carriage LLTHC 15 U-T2 P5).

Electrical connection of th PS01-37S stators

Attention!

Do not connect or disconnect motor while there is power on the servo drive.

Use only double shielded original LinMot cable. Cables from other sources must be checked precisely before commissioning. Incorrect connections can destroy the drive and stator.



Connector Type		N-Connector	
Series		PS01-37Sx60F-HP-N PS01-37Sx120F-HP-N	
		PIN	Wire
Phase1+		4	red
Phase1-		3	pink
Phase2+		2	blue
Phase2-		1	grey
+5V		A	white
GROUND*		B	Inner shield
Sensor Sin		C	yellow
Sensor Cos		D	green
Temp sensor		E	black
SHIELD* of stator and stator cable		Case (cable relief)	Outer shield
Connector on the stator (-cables)			

(The electrical connection of PS01-37Sx60-HP-N-AGI and PS01-37Sx120-HP-N-AGI is identical to the versions PS01-37Sx60-HP-N and PS01-37Sx120-HP-N)

Adapter cables are available with different connectors and in different length. Please find a list of these options in the LinMot data book on www.linmot.com. If you need a special cable, please contact LinMot directly (see contact information on last page).

Installation of the motor cable

Depending on the direction of the cable exit, it may happen that the cables are above the screw holes. It is important to ensure that the screw holes are available before screwing!

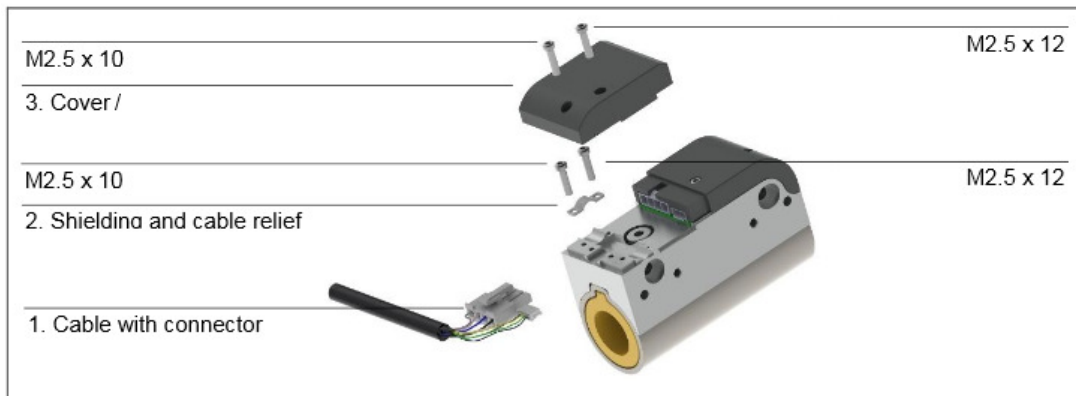

In every case make sure that the cable is properly secured outside of the stator (see arrow!) and the bending radius of the high-flex cable is maintained:

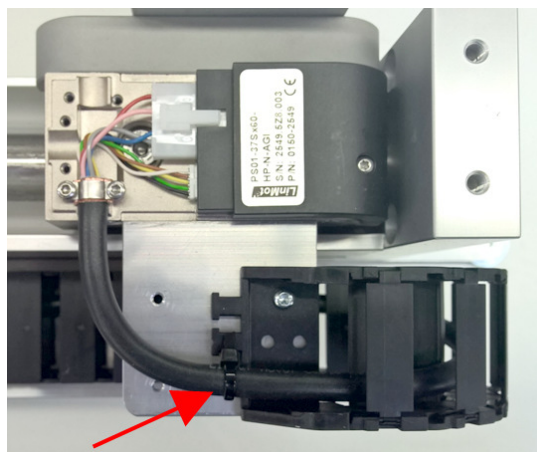

KS03 high flex cable: min. bending for fix installation: 1 inch
min. bending for moving applications: 2 inch

Maintenance

Maintenance of Carriages

Relubrication of carriages

The lubrication intervals for profile rail guides depend primarily on the average running speed, operating temperature and grease quality. Where contamination, use of coolants, vibration, shock loads etc. form part of the environmental conditions, it is advisable to increase re-lubrication intervals accordingly.

The following re-lubrication intervals should be used until empirical values are available.

for velocities $v < 1\text{m/s}$
Constant main load $< 0.30 C$ every 1200 km

(C = Load Capacity)

See SKF Manual 'Profile rail guides LLT' (www.SKF.com, document: 12942_1_EN_LLT_2013.pdf) for additional information about lifetime and maintenance.

Quantity of lubricant for carriages

Quantity of lubricant:= $0,4\text{ cm}^3$

Lubricant for carriages

Lubricant: SKF LGEP 2

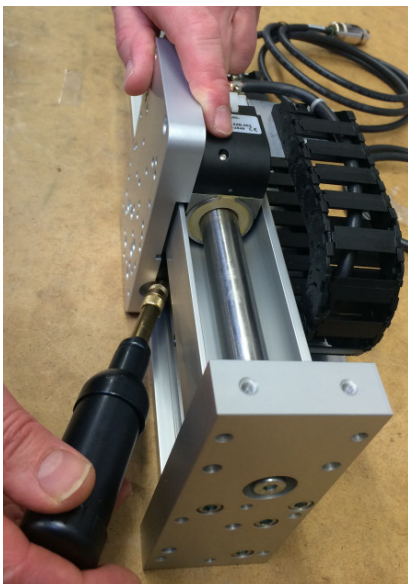
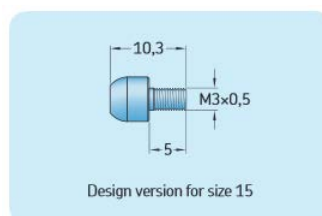

Figure: Relubrication with grease press.



Grease nipple

Maintenance of LinMot Motors

LinMot Stators will be shipped with an initial lubrication. Maintenance will only be required if the motors run 'dry' or there is a heavy pollution of the motors.

Under normal industrial conditions (5 days, 8hr/day) one inspection every 3 months is adequate. Where conditions differ, as with severe and permanent fouling, direct sunshine, operation out in the open, increased operating temperature etc., the maintenance intervals must be shortened till empirical values for the particular application are obtained.

Assembling of the Motors

The sliders must be cleaned first. Sliders with a length of more than 500 mm (20 in) must be lubricated with LU02. Lubricate the slider with a soft fabric or manually. 4 g of lubricant per meter slider is enough to create a film of lubricant on the surface of the sliders. (4 g (0.14 oz) is about ½ of a hazelnut). Do not over lubricate! Especially in higher operating temperatures, over lubrication can lead to a gumming of the lubricant. (In such a situation the motor must be cleaned completely.)

Inspection

Inspections have to be executed according to the operating condition and the load of motors. Following points have to be checked during inspection:

- Is a film of lubricant on the slider?
- Is the lubricant not sticky?
- Can the slider be moved easily?

If the motors are heavily polluted respectively if no film of lubricant is on the slider, then stators and sliders must be cleaned and lubricated again.

Cleaning

Pull the sliders carefully out of the Stator: Attention: huge magnetic attraction! Use non magnetic material (e.g. wood) to cover close-by iron constructions. Clean slider completely with cleaning agent LU06. The stators should also be cleaned with a soft fabric and LU06 until all dirt is removed. After that lubricate the bore of the stators with about 2-3 g (=0.1 oz) Lubricant LU02. There should only be a slight film of lubricant. Do not over lubricate! Slider should be lubricated according to the chapter 'Assembling of the Motors'.

Lubricant

The lubricant reduces the friction between the chromium-nickel steel surface of the slider and the reinforced plastic plain bearing.

The following lubricant is recommended:

LinMot® Lubricant LU02-08	(8g)	Art. No. 0150-1953
LinMot® Lubricant LU02-50	(50g)	Art. No. 0150-1954
LinMot® Lubricant LU02-1000	(1000g)	Art. No. 0150-1955

LinMot® LU02 Lubricant corresponds to KLÜBERSYNTH UH1 14-31 which was developed for the food processing industry.

Cleaning Agent

The following Cleaning Agent spray is recommended for LinMot Stators and Sliders:

***LinMot®* Spray LU06-250 (250ml) Art. No. 0150-2394**

LinMot® LU06 Lubricant corresponds to KLÜBERSYNTH NH1 4—2 which was developed for the food processing industry.

Storage / transport

Sliders are to be stored and transported only in the plastic containers (with cardboard inlay) provided for this, or already fitted in *LinMot®* motors and secured.

Maximum storage temperature: 70 °C

Caution: Handling Instructions for Sliders

LinMot Slider

LinMot® Linear Motor sliders must be handled with care especially if not assembled within the stator! Damaging or warping of the slider can result in shortened life and/or failure of the motor. The slider is essentially a high-precision machine component consisting of neodymium magnets and plastic materials assembled in a thin steel tube. Do not use sliders who are already damaged on the surface (scratches, deformation, etc.). This can provide a further damage of the stator! Keep slider away from unshielded flame or heat. Temperature of more than 120°C will cause demagnetization.



Magnetism

LinMot® sliders contain neodymium magnets which may disturb or damage magnetic data carriers and delicate electronic equipment merely by coming close to them. Examples for such equipment are: television and computer monitors, credit cards and EC-cards, computers, floppy discs and other data storage medium, video tapes, mechanical watches, hearing devices and loudspeaker. Heart pacemakers can be disturbed by strong magnets. Keep a minimum distance of 1m.



Crushing

When handling sliders be aware that, due the strong magnetic attraction, serious injury from fingers being pinched between the slider and nearby steel parts is a very real possibility if caution is not exercised.



No modification of sliders provided to customers is allowed!

Do not modify the slider in any way. Any modification could destroy the included magnets and magnet dust can be generated. Magnet dust is flammable! NdFeB-Magnets are not made of steel. These magnets are sintered and therefore highly breakable.



Drawings F01-37S

Stroke Range F01-37S guide

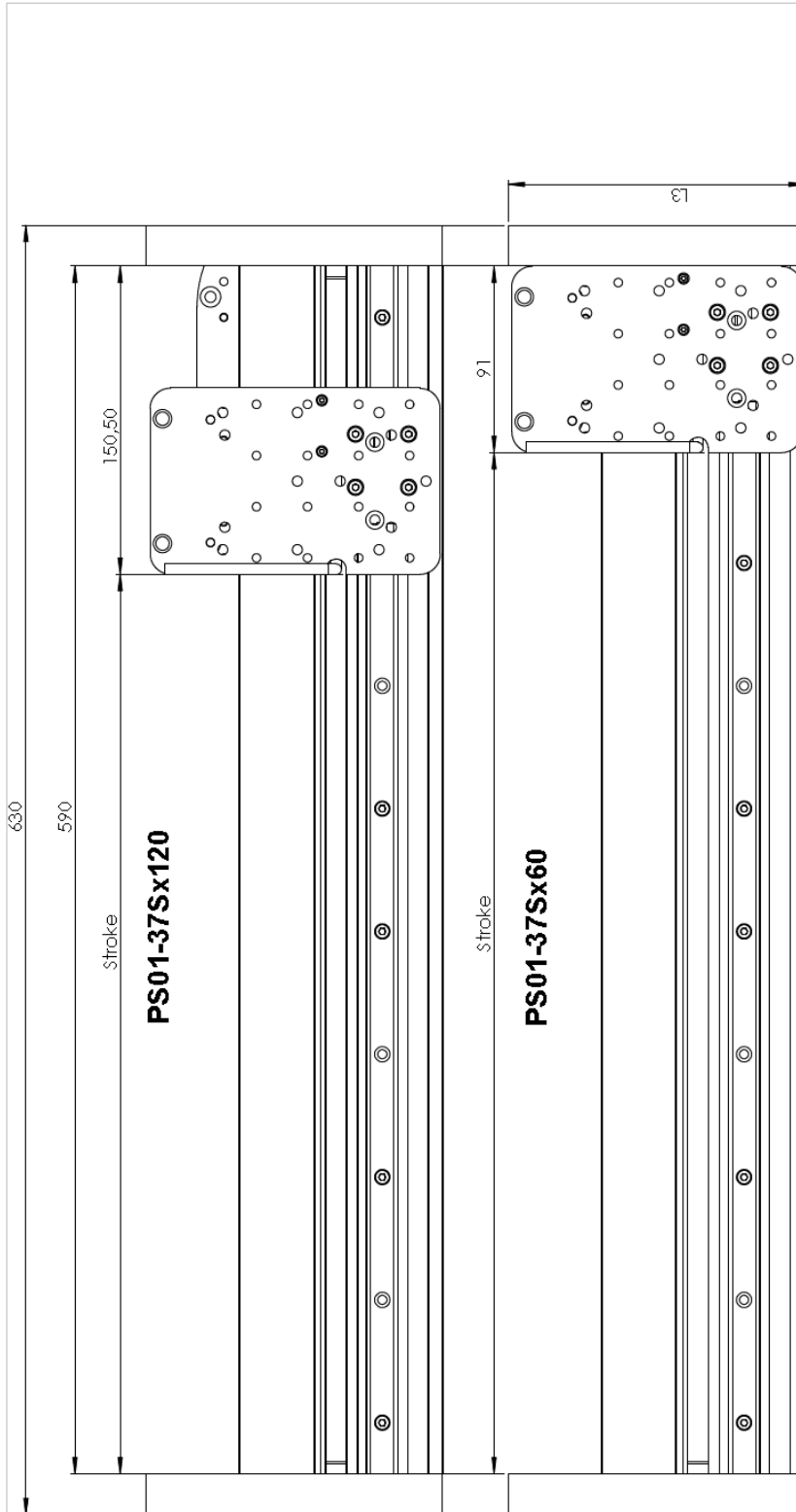

	L1	L2	Stroke PS01-37Sx60	Stroke PS0137Sx120	Tolerance Stroke
F01-37Sx300	330	290	200	140	+0 / -5
F01-37Sx400	430	390	300	240	+0 / -5
F01-37Sx500	530	490	400	340	+0 / -5
F01-37Sx600	630	590	500	440	+0 / -5
F01-37Sx800	830	790	600	640	+0 / -5
F01-37Sx1000	1030	990	700	840	+0 / -5
F01-37Sx1200	1230	1190	110	1040	+0 / -5
F01-37Sx1400-F	1430	1390	1300	1240	+0 / -5
F01-37Sx1600-F	1630	1590	1500	1440	+0 / -5
F01-37Sx2000-F	2030	1990	1900	1840	+0 / -5

F01-37S
Stroke Range

Gezeichnet: 05.06.2014 D. Marinkovic
 Datename: 0180-0719_HubbereichF01

Material: **LinMot**
 Ersatz für: 12.02.2015/dm
 Status: 12.02.2015/dm
 Änderungen: A 12.02.2015/dm

Zeichnungsnummer: 0180-0719 A
 Format: A3

NTI AG, LinMot
 Maßstab: 1:2

Alle Abmessungen sind in mm angegeben. Die Abmessungen sind ohne Gewähr. Ohne unsere schriftliche Genehmigung darf das Dokument weder kopiert noch vervielfältigt noch Dritten mitgeteilt oder zugänglich gemacht werden.

Dimensions F01-37S guide

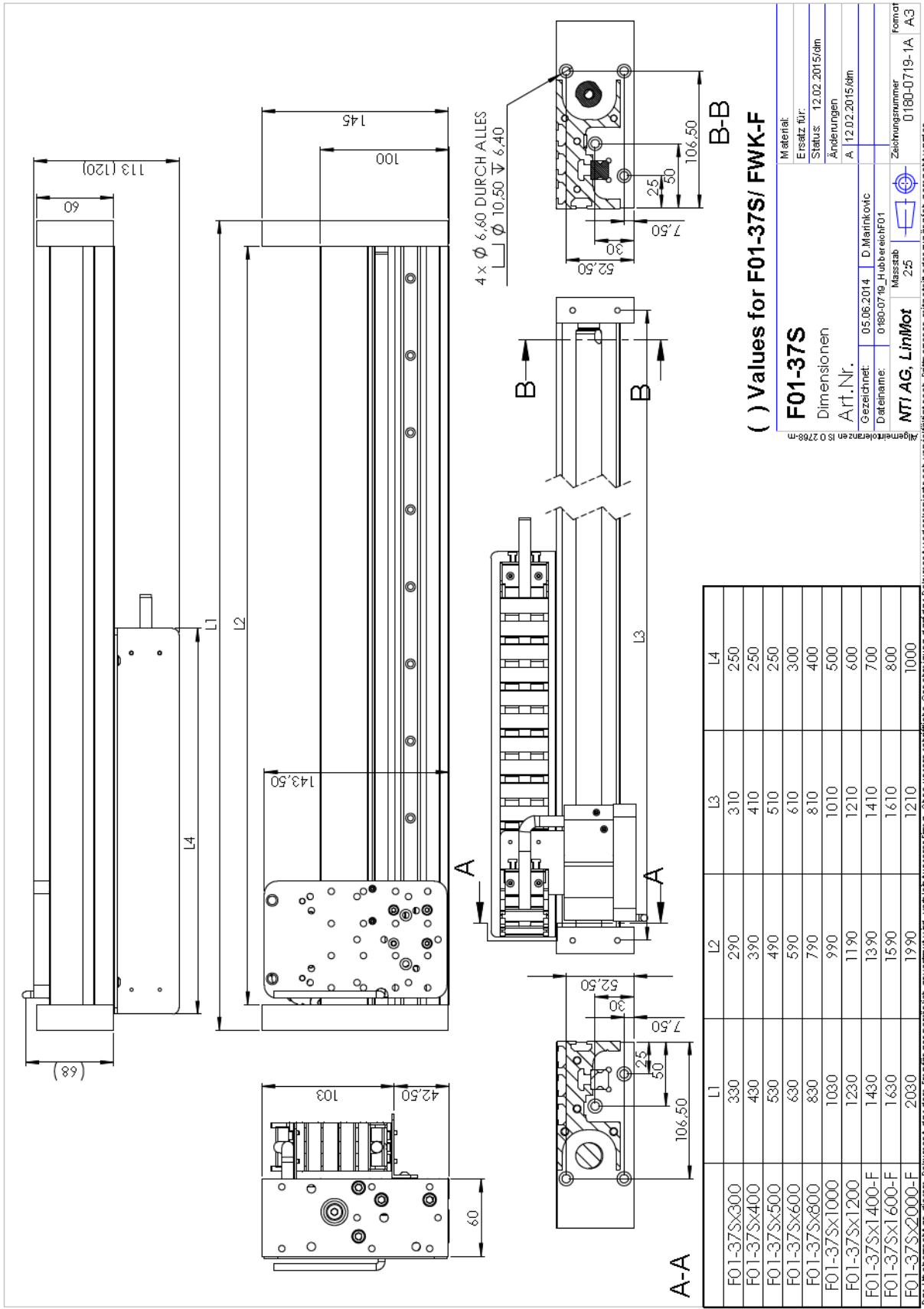

Dimensions F01-37S-AP ground plate

Solely LinMot Product			
Label	X-POS.	Y-POS.	Dimensionen
C1	12	106,50	PR01-52
C2	23	24	Gantry
C3	23	105,50	Gantry
C4	26,50	32	H01-23
C5	45,50	49	Gantry
C6	64,50	32	H01-23
C7	68	24	Gantry
C8	68	105,50	Gantry
C9	79	30	PR01-52
C10	79	106,50	PR01-52
C11	12	30	PR01-52

Solely LinMot Product			
Label	X-POS.	Y-POS.	Dimensionen
D1	15	136	H01-37
D2	76	136	H01-37

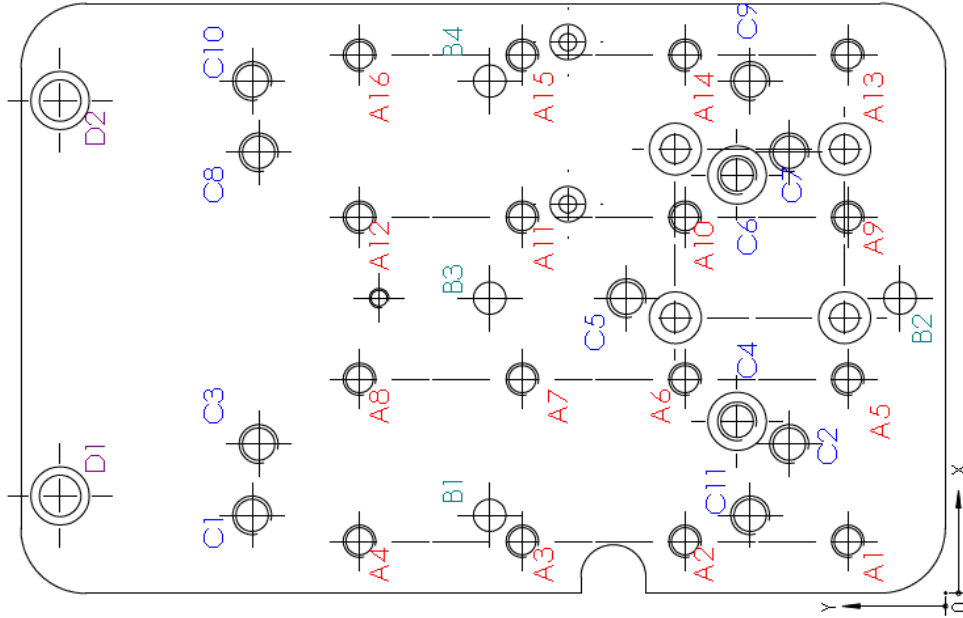

Option holes			
Label	X-POS.	Y-POS.	Dimensionen
A1	8	15	M5x12
A2	8	40	M5x12
A3	8	65	M5x10
A4	8	90	M5x10
A5	33	15	M5x12
A6	33	40	M5x12
A7	33	65	M5x10
A8	33	90	M5x10
A9	58	15	M5x12
A10	58	40	M5x12
A11	58	65	M5x10
A12	58	90	M5x10
A13	83	15	M5x12
A14	83	40	M5x12
A15	83	65	M5x10
A16	83	90	M5x10

Central mounting hole			
Label	X-POS.	Y-POS.	Dimensionen
B1	12	70	Ø5x10
B2	45,50	7	Ø5x10
B3	45,50	70	Ø5x10
B4	79	70	Ø5x10

F01-37S-AP
Ground plate
Dimensions

Gezeichnet: 11.06.2014 D. Marinkovic
Dateiname: 0180-0719_HubereichF01
Massestab 3:2
Zeichnungsnummer 0180-0719-5A A3

Material:
Ersatz für:
Status: 12.02.2015/dm
Änderungen
A. 12.02.2015/dm

MTI AG, LinMot
Hubbereich F01
D. Marinkovic
0180-0719-5A A3

Das Urheberrecht an diesem Dokument, das dem Empfänger persönlich anvertraut wird, verbleibt unserer Firma. Ohne unsere schriftliche Genehmigung darf das Dokument weder kopiert noch veröffentlicht noch in irgendeiner Weise weitergegeben werden.

Dimensions F01-37S end plates

Option holes		
Label	X-POS, Y-POS.	Dimensions
A1	6 14,50	∅ 5 ∇ 17 M6 - 6H ∇ 12
A2	6 59,50	∅ 5 ∇ 17 M6 - 6H ∇ 12
A3	6 129,50	∅ 5 ∇ 17 M6 - 6H ∇ 12
A4	54 14,50	∅ 5 ∇ 17 M6 - 6H ∇ 12
A5	54 59,50	∅ 5 ∇ 17 M6 - 6H ∇ 12
A6	54 129,50	∅ 5 ∇ 17 M6 - 6H ∇ 12

Gantry Rear		
Label	X-POS, Y-POS.	Dimensions
D1	7,50 25	∅ 6,60 DURCH ALLES ∇ ∅ 11 ∇ 6,40
D2	7,50 106,50	∅ 6,60 DURCH ALLES ∇ ∅ 11 ∇ 6,40
D3	30 50	∅ 6,60 DURCH ALLES ∇ ∅ 11 ∇ 6,40
D4	52,50 106,50	∅ 6,60 DURCH ALLES ∇ ∅ 11 ∇ 6,40

Gantry Front		
Label	X-POS, Y-POS.	Dimensions
C1	7,50 106,50	∅ 6,60 DURCH ALLES ∇ ∅ 10,50 ∇ 6,40
C2	30 50	∅ 6,60 DURCH ALLES ∇ ∅ 10,50 ∇ 6,40
C3	52,50 25	∅ 6,60 DURCH ALLES ∇ ∅ 10,50 ∇ 6,40
C4	52,50 106,50	∅ 6,60 DURCH ALLES ∇ ∅ 10,50 ∇ 6,40

Central mounting hole		
Label	X-POS, Y-POS.	Dimensions
B1	30 8	+0,012 ∅ 5 H7 0 ∇ 12
B2	30 71	+0,012 ∅ 5 H7 0 ∇ 12

F01-37S

End Plate Dimensions

Material:
Ersatz für:
Status: 10.03.2015/aim
Änderungen:

Gezeichnet: 12.03.2015 D. Marinkovic
Dateiname: 0180-0710_HubbereichF01
Messstab 23
Zeichnungsnummer 0180-0719-8
Format A3

Das Urheberrecht an diesem Dokument, das dem Empfänger persönlich anvertraut wird, verbleibt unserer Firma. Ohne unsere schriftliche Genehmigung darf das Dokument weder kopiert noch veröffentlicht noch Dritten mitgeteilt oder zugänglich gemacht werden.

Dimensions F01-37S T-slots

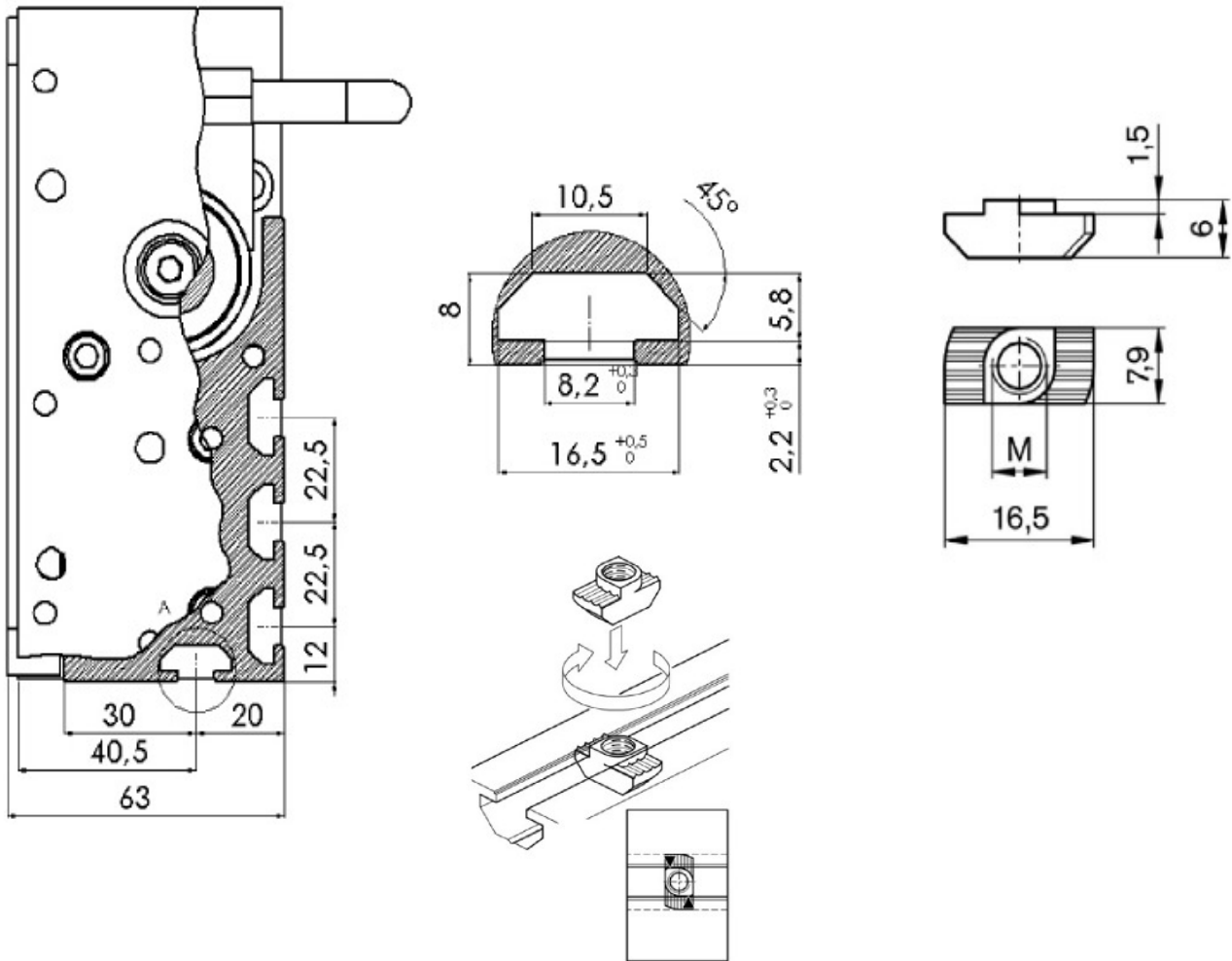

Description	Part-No	
Nut N8 / M4	0150-2189	Nut for 8 mm slots of F01-37S guides with M4 thread
Nut N8 / M6	0150-2558	Nut for 8 mm slots of F01-37S guides with M6 thread

Dimensions with H01-23x86 guide

() Values for F01-37S/ FWK-F

F01-37S-H01-23

Dimensionen
Art.Nr.

Material	
Ersatz für:	
Status:	12.02.2015/dm
Änderungen	
A	12.02.2015/dm
Gezeichnet:	05.06.2014 D. Matkovic
Datenname:	0180-0719_HubbereichF01
Messstab	2:5
Zeichnungsnummer	0180-0719-2A
Format	A3

	L1	L2
F01-37Sx300	330	290
F01-37Sx400	430	390
F01-37Sx500	530	490
F01-37Sx600	630	590
F01-37Sx800	830	790
F01-37Sx1000	1030	990
F01-37Sx1200	1230	1190
F01-37Sx1400-F	1430	1390
F01-37Sx1600-F	1630	1590
F01-37Sx2000-F	2030	1990

Das LinMot an diesem Dokument, das dem Empfänger persönlich anvertraut wird, verleiht unserer Firma, ohne unsere schriftliche Genehmigung, das Dokument weder kopiert noch veröffentlicht zu werden.

Dimensions with H01-37x166 guide

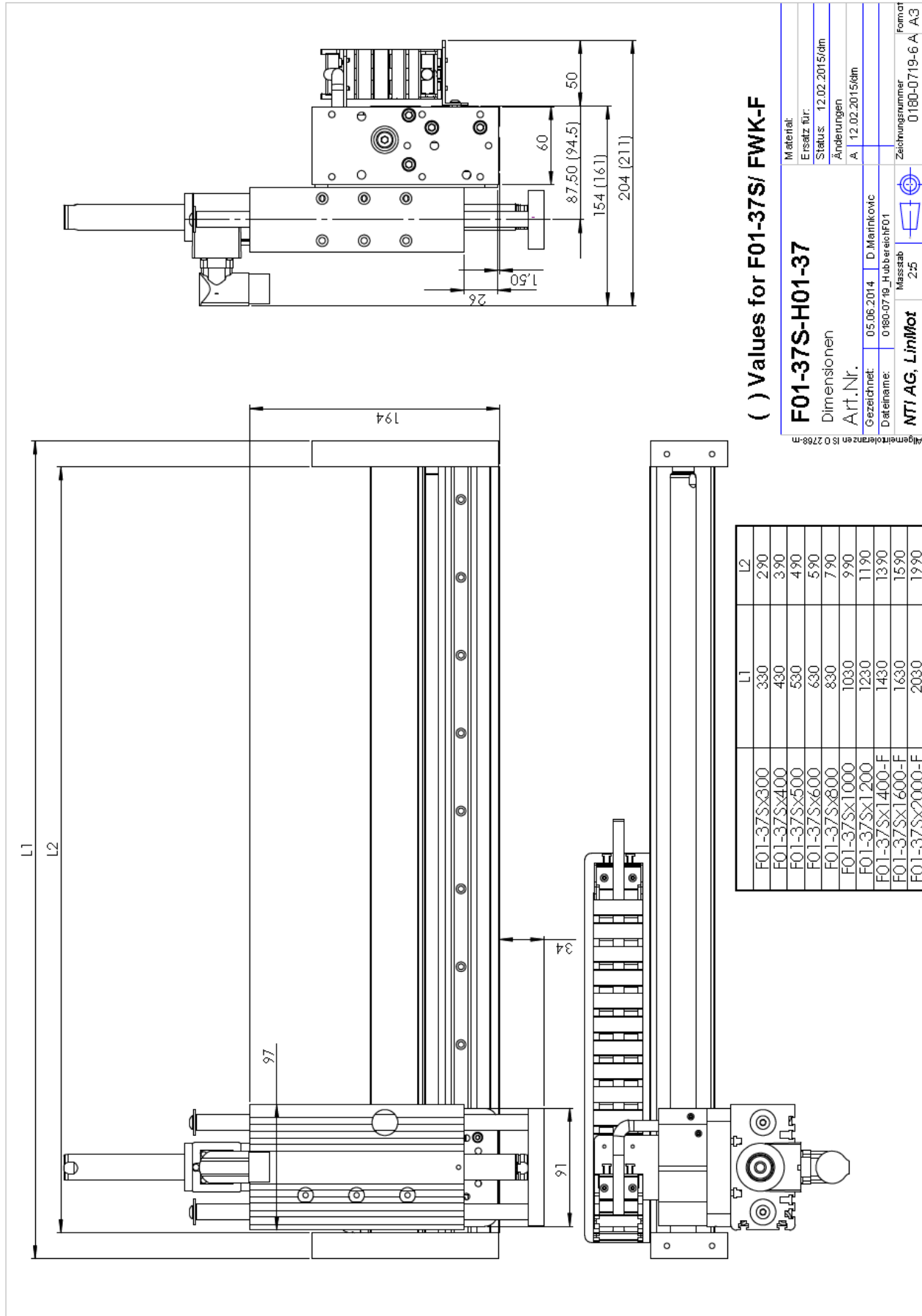

Dimensions with PR01-52x40-R/37x120F-HP-C-80/-L

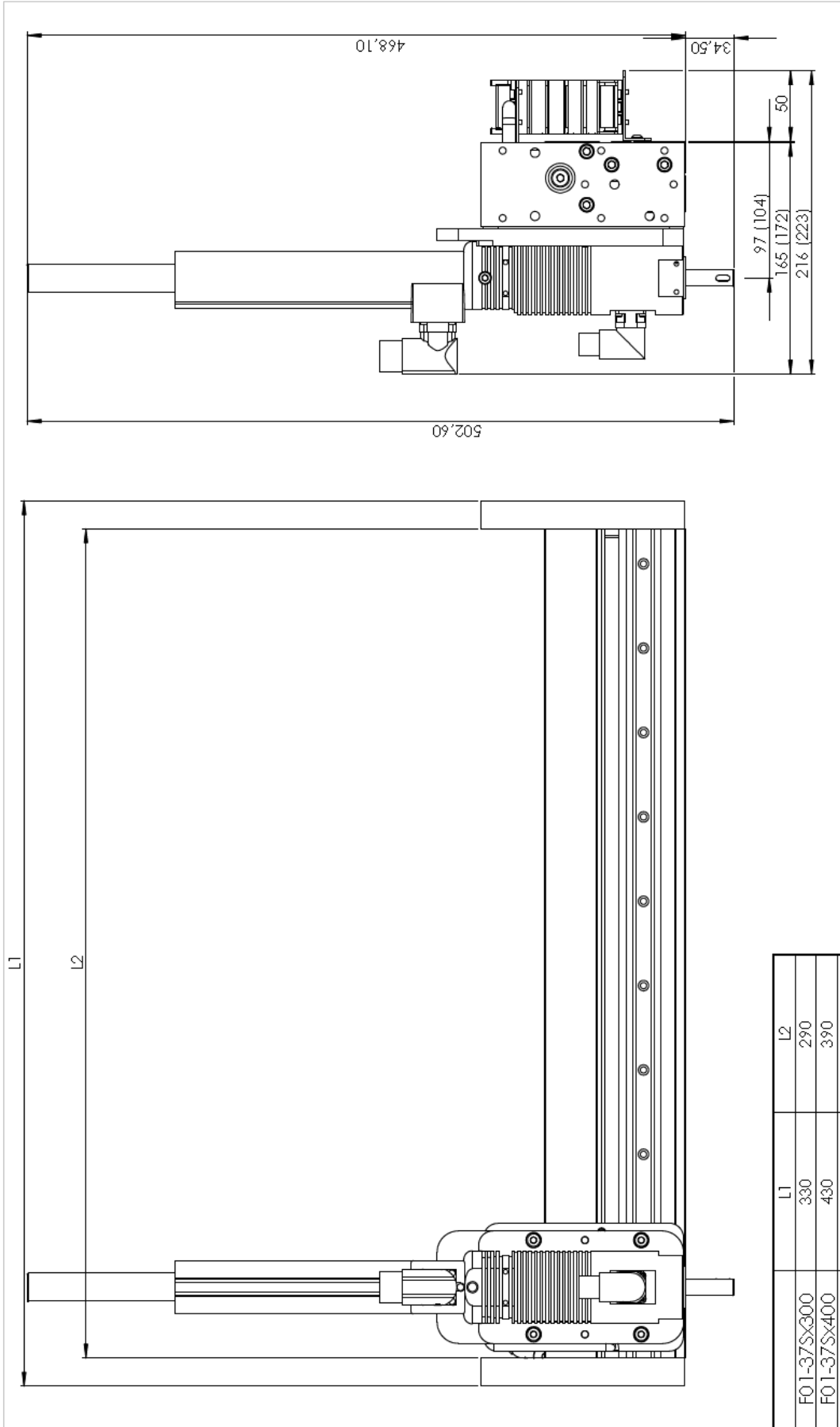

() Values for F01-37S/ FWK-F

	L1	L2
F01-37Sx300	330	290
F01-37Sx400	430	390
F01-37Sx500	530	490
F01-37Sx600	630	590
F01-37Sx800	830	790
F01-37Sx1000	1030	990
F01-37Sx1200	1230	1190
F01-37Sx1400-F	1430	1390
F01-37Sx1600-F	1630	1590
F01-37Sx2000-F	2030	1990

F01-37S-PR01-52X40
Dimensionen
Art.Nr.

Material: Ersatz für:
Status: 12.02.2015/dm
Änderungen: A 12.02.2015/dm

Gezeichnet: 05.06.2014 D. Matinkovic
Dateiname: 0180-0719_HubbereichF01

Messstab: 2:5
Zeichnungsnummer: 0180-0719-3A
Format: A3

NTI AG, LinMot

Alle Maßeinheiten sind in mm angegeben. © 2015 LinMot AG. Alle Rechte vorbehalten. Nachdruck, Vervielfältigung und Verbreitung, auch auszugsweise, ist ohne schriftliche Genehmigung LinMot AG. Dieses Dokument ist eine Kopie eines Originaldokuments. Die Kopie ist nicht verbindlich und kann Änderungen enthalten. Die Verantwortung für die Richtigkeit der Informationen in diesem Dokument liegt bei dem Empfänger. Dieses Dokument ist eine Kopie eines Originaldokuments. Die Kopie ist nicht verbindlich und kann Änderungen enthalten. Die Verantwortung für die Richtigkeit der Informationen in diesem Dokument liegt bei dem Empfänger.

Dimensions with PR01-52x60-R/37x120F-HP-C-100/-L

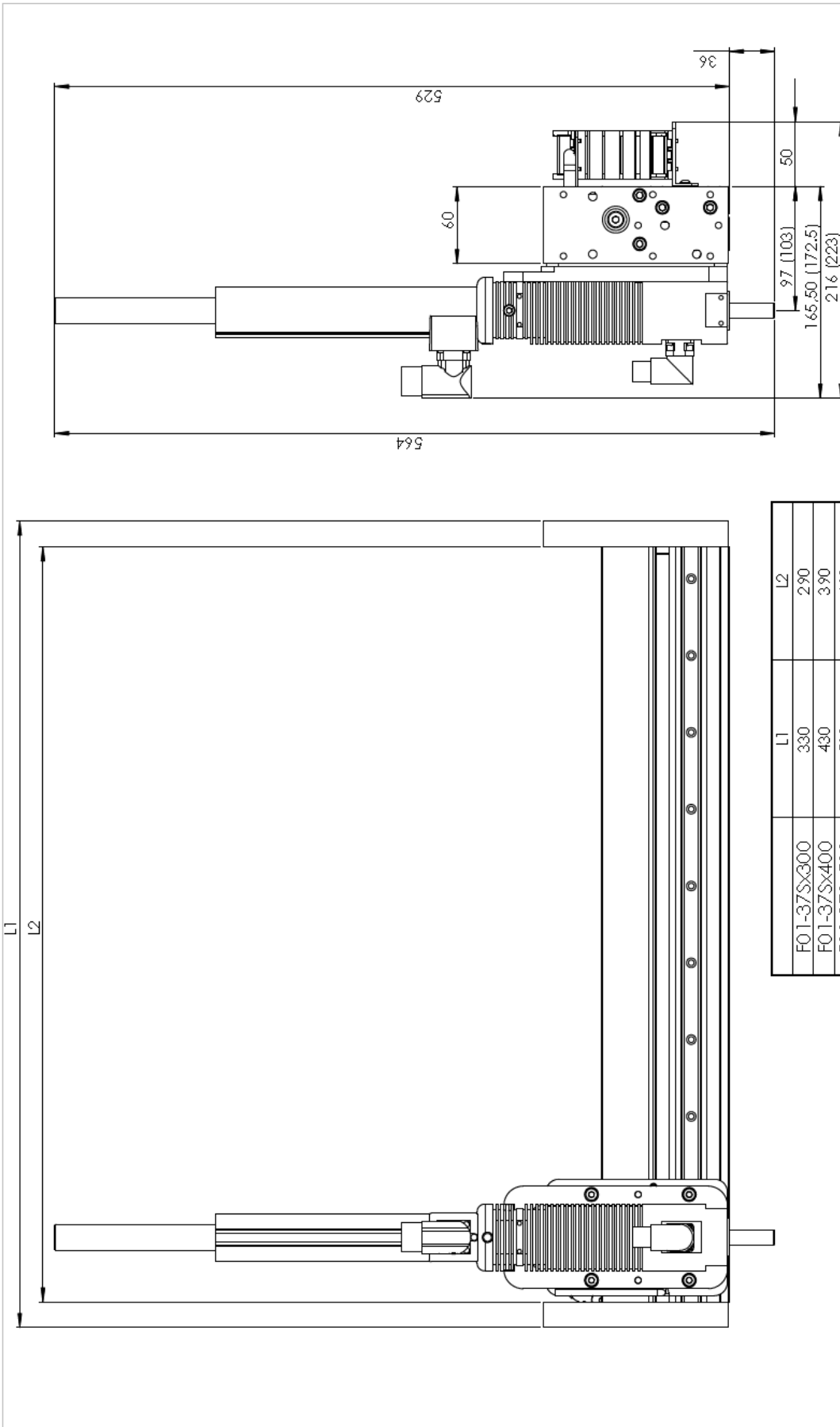

F01-37S-PR01-52x60

Dimensionen
Art.Nr.

Material:
Ersatz für:
Status: 12.02.2015/dm
Änderungen
A 12.02.2015/dm

Gezeichnet: 05.06.2014 D. Mainkovic
Dateiname: 0180-0719_HubtriebF01

NTI AG, LinMot
Massstab 4:1

Zeichnungsnummer 0180-0719-4A
Format A3

Änderungen sind 2786-m

	L1	L2
F01-37Sx300	330	290
F01-37Sx400	430	390
F01-37Sx500	530	490
F01-37Sx600	630	590
F01-37Sx800	830	790
F01-37Sx1000	1030	990
F01-37Sx1200	1230	1190
F01-37Sx1400-F	1430	1390
F01-37Sx1600-F	1630	1590
F01-37Sx2000-F	2030	1990

() Values for F01-37S/ FWK-F

Das Linearteil an diesem Dokument, das dem Empfänger persönlich anvertraut wird, bleibt unser Eigentum. Ohne unsere schriftliche Genehmigung darf das Dokument weder kopiert noch veröffentlicht werden.

Dimensions with PR01-52x60-R/37x120F-HP-C-100-G

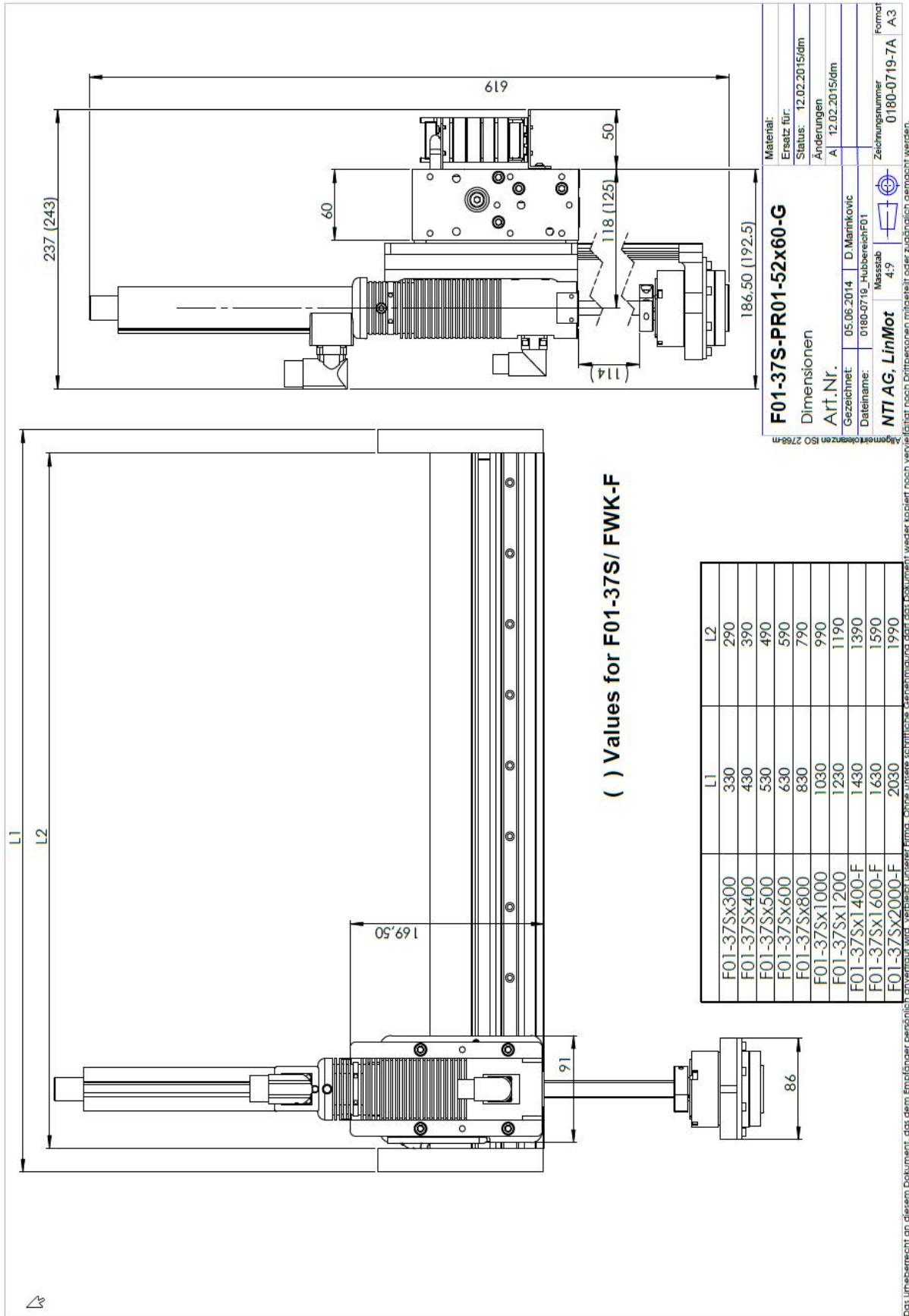

Drawings F01-48

Stroke Range F01-48 guide

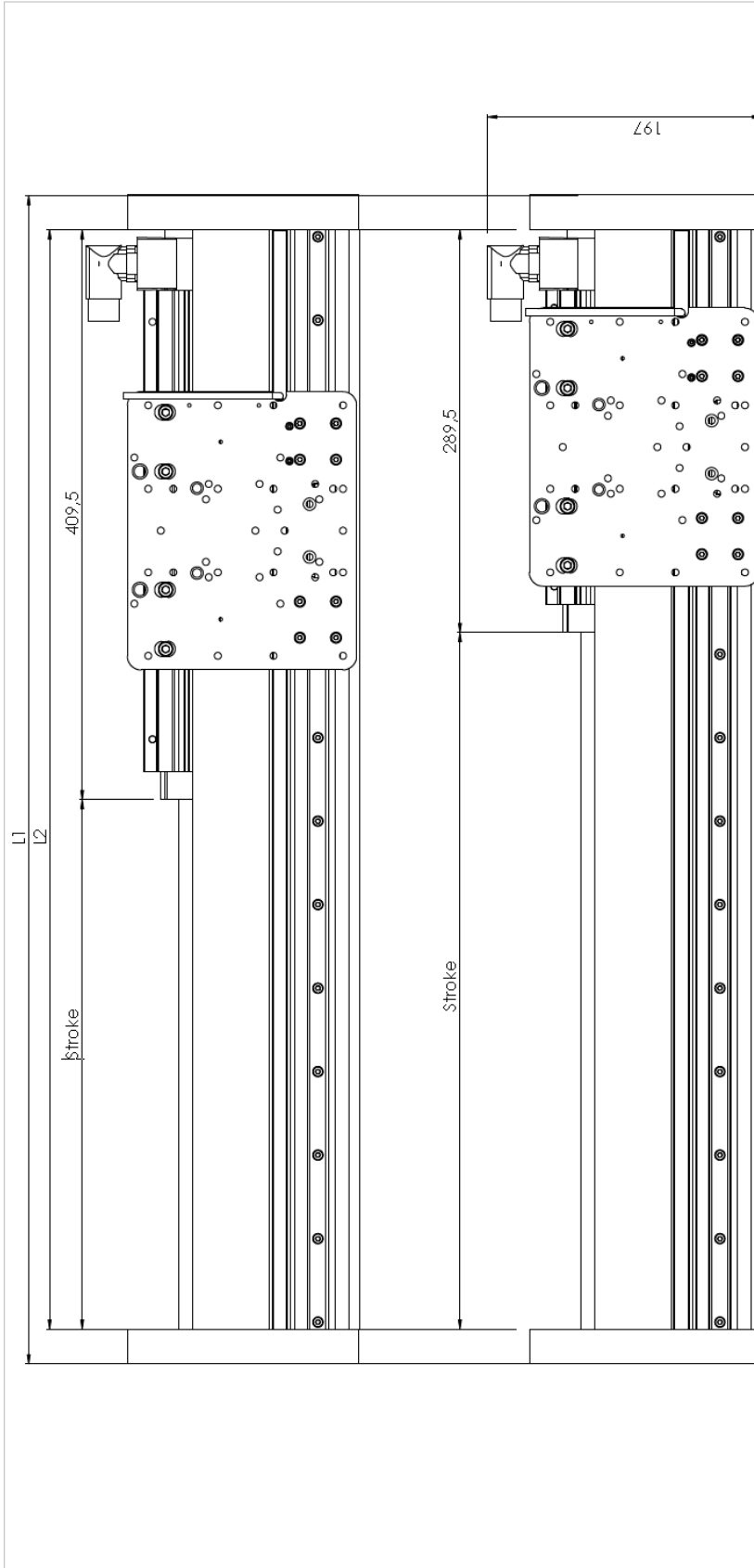

	L1	L2	Stroke PS01-48x240F-C	Stroke PS01-48x360F-C
F01-48x500	540	490	200,5	80,5
F01-48x620	660	610	320,5	200,5
F01-48x800	840	790	500,5	380,5
F01-48x1010	1050	1000	710,5	590,5
F01-48x1220	1260	1210	920,5	800,5
F01-48x1400	1440	1390	1100,5	980,5
F01-48x1610	1650	1600	1310,5	1190,5
F01-48x1820	1860	1810	1520,5	1400,5
F01-48x2000	2040	1990	1700,5	1580,5
F01-48x2210	2250	2250	1960,5	-
F01-48x2450	2490	2440	2150,5	-

F01-48
Stroke Range

Gezeichnet: 05.06.2015 D. Mairnkovic
 Datei Name: unaldrse-hinweise_F01-48
 NTI AG, LinMot
 Massstab: 1:2

Material:
 Ersatz für:
 Status: 06.06.2016/dm
 Änderungen:

Änderungsbogen: 0180-0788
 Zeichnungsnummer: 0180-0788
 Format: A2

Kleinformatzeichen ISO 2798-m
 Genehmigungen: 150 2798-m
 Das LinMot-Engineering ist ein eingetragenes Warenzeichen der LinMot AG. Alle Rechte vorbehalten. Die LinMot-Engineering ist ein eingetragenes Warenzeichen der LinMot AG. Alle Rechte vorbehalten. Die LinMot-Engineering ist ein eingetragenes Warenzeichen der LinMot AG. Alle Rechte vorbehalten.

Dimensions F01-48 guide

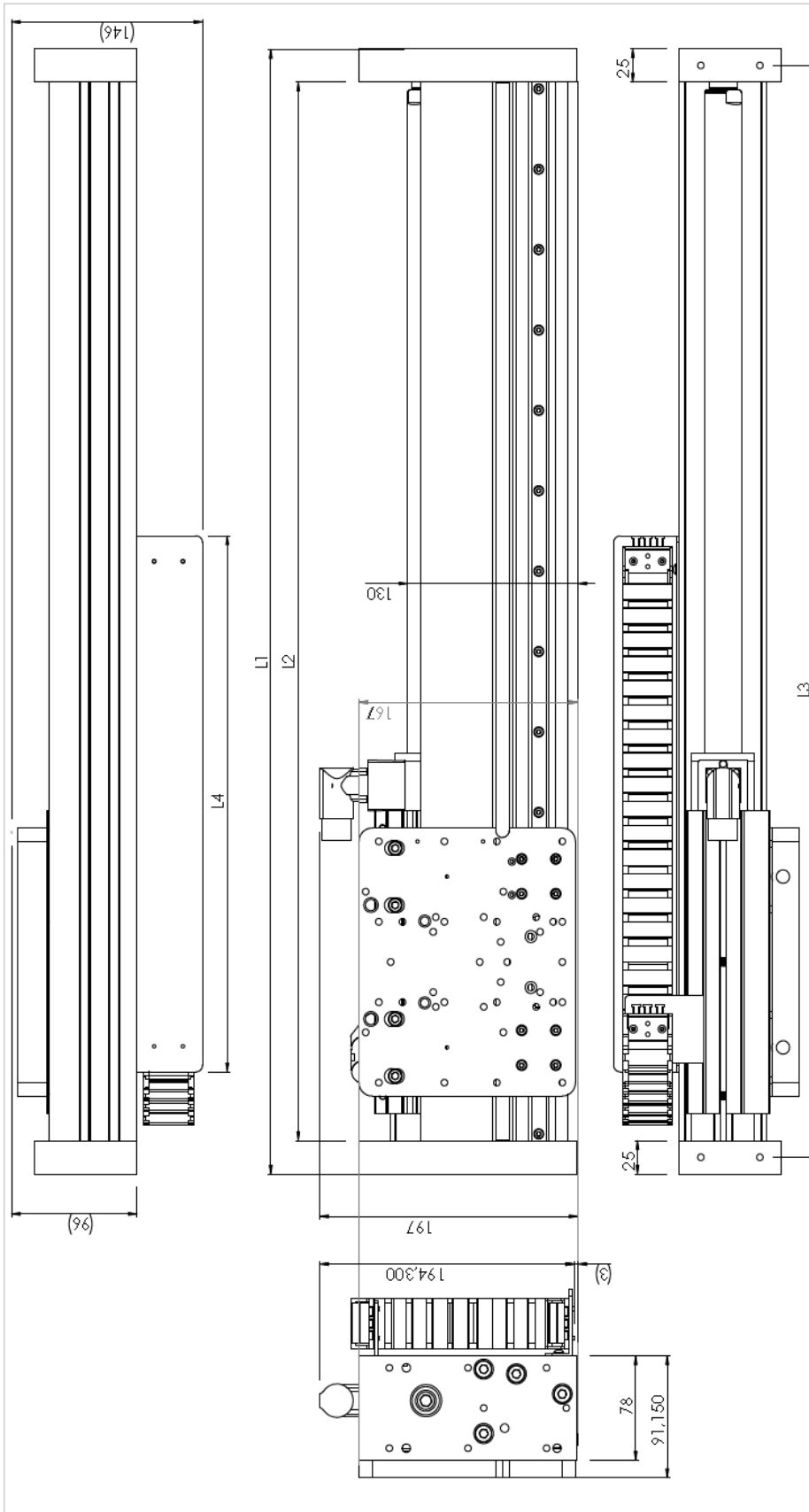

	L1	L2	L3	L4
F01-48x500	540	490	615	250
F01-48x620	660	610	635	300
F01-48x800	840	790	815	400
F01-48x1010	1050	1000	1025	500
F01-48x1220	1260	1210	1235	600
F01-48x1400	1440	1390	1415	700
F01-48x1610	1650	1600	1625	800
F01-48x1820	1860	1810	1835	800
F01-48x2000	2040	1990	2015	1000
F01-48x2210	2250	2200	2225	1000
F01-48x2450	2490	2440	2465	1250

F01-48
Dimensions
 Gezeichnet: 06.06.2016 D. Marinkovic
 Datei name: inbauraussen_01r-48
 Masstab: 1:2
 Material: Ersatz für:
 Status: 05.06.2016m
 Änderungen:
 Zeichnungsnummer:
 0180-0768-2
 Format:
 A2

Alle Rechte vorbehalten. Ohne unsere schriftliche Genehmigung darf das Dokument weder kopiert noch veröffentlicht werden. Die Weitergabe ist untersagt.

Dimensions F01-48 ground plate

Solely LinMot Produkt			
Label	X-POS.	Y-POS.	Dimensions
C1	47,50	55	PR01-84 / PR01-84G
C2	47,50	160	PR01-84 / PR01-84G
C3	66,50	30	PR01-52 / PR01-52G
C4	66,50	106,50	PR01-52 / PR01-52G
C5	70	17	Gantry F01-48
C6	70	132	Gantry F01-48
C7	77,50	27	Gantry F01-37S
C8	77,50	108,50	Gantry F01-37S
C9	85	57	Gantry F01-48
C10	100	52	Gantry F01-37S
C11	115	57	Gantry F01-48
C12	122,50	27	Gantry F01-37S
C13	122,50	108,50	Gantry F01-37S
C14	130	17	Gantry F01-48
C15	130	132	Gantry F01-48
C16	133,50	30	PR01-52 / PR01-52G
C17	133,50	106,50	PR01-52 / PR01-52G
C18	152,50	55	PR01-84 / PR01-84G
C19	152,50	160	PR01-84 / PR01-84G

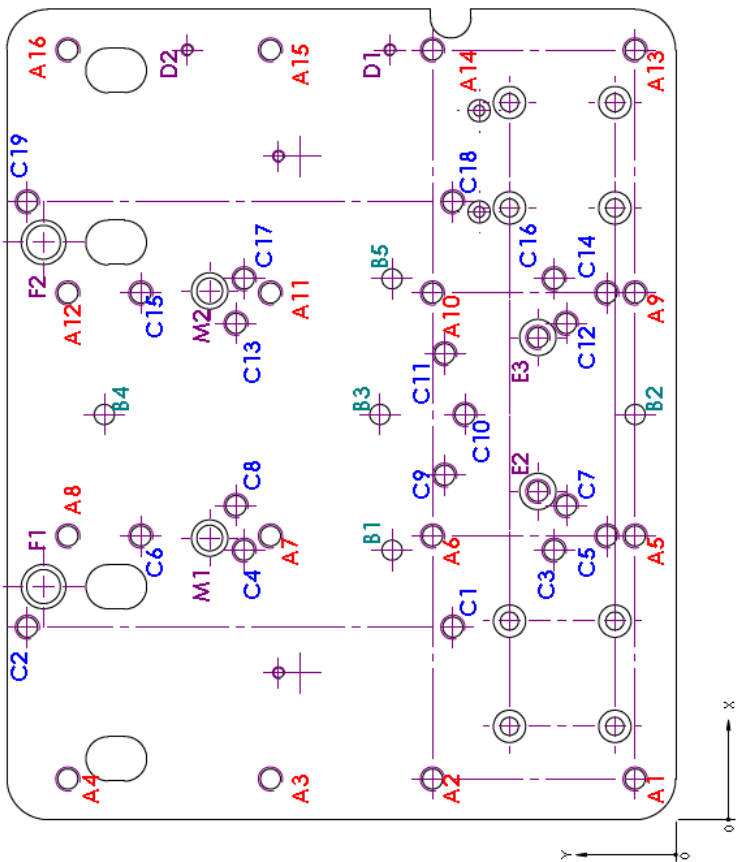

Option holes			
Label	X-POS.	Y-POS.	Dimensions
A1	10	10	M6x18
A2	10	60	M6x18
A3	10	100	M6x18
A4	10	150	M6x18
A5	70	10	M6x18
A6	70	60	M6x18
A7	70	100	M6x18
A8	70	150	M6x18
A9	130	10	M6x18
A10	130	60	M6x18
A11	130	100	M6x18
A12	130	150	M6x18
A13	190	10	M6x18
A14	190	60	M6x18
A15	190	100	M6x18
A16	190	150	M6x18

Solely LinMot Produkt			
Label	X-POS.	Y-POS.	Dimensions
D1	190	70,50	Kabel
D2	190	120,50	Kabel
E2	81	34	H01-23
E3	119	34	H01-23
F1	57,50	156	H01-48
F2	142,50	156	H01-48
M1	69,50	115	H01-37
M2	130,50	115	H01-37

Central mounting hole			
Label	X-POS.	Y-POS.	Dimensions
B1	66,50	70	Ø 5 √ 12
B2	100	10	Ø 5 √ 12
B3	100	73	Ø 5 √ 12
B4	100	141	Ø 5 √ 12
B5	133,50	70	Ø 5 √ 12

F01-48-APW-F
Ground Plate
Dimensions

Material: Stahl
Einsatz für: DE Dimensionen
Status: Änderungen

Bezeichnet: 05.06.2015
Dateiname: D:\Marketing\...
D:\Marketing\...
D:\Marketing\...
D:\Marketing\...

Zeichnungskennzeichen: 0180-0788-3
Formel: A2

NTI AG, LinMot
Masse: 43
Zugfestigkeit:

Alle Maße sind in mm angegeben.
Das ist ein Entwurfsdokument.
Das ist ein Entwurfsdokument, das dem Empfänger persönlich anvertraut wird, verbleibt unserer Firma, ohne unsere schriftliche Genehmigung darf das Dokument weder kopiert noch veröffentlicht noch Dritten anvertraut werden.

Dimensions F01-48 end plate

Option holes		
Label	X-POS.	Y-POS.
A1	9	23
A2	9	83
A3	9	143
A4	69	23
A5	69	83
A6	69	143

Central Mounting hole		
Label	X-POS.	Y-POS.
B1	39	71
B2	39	8

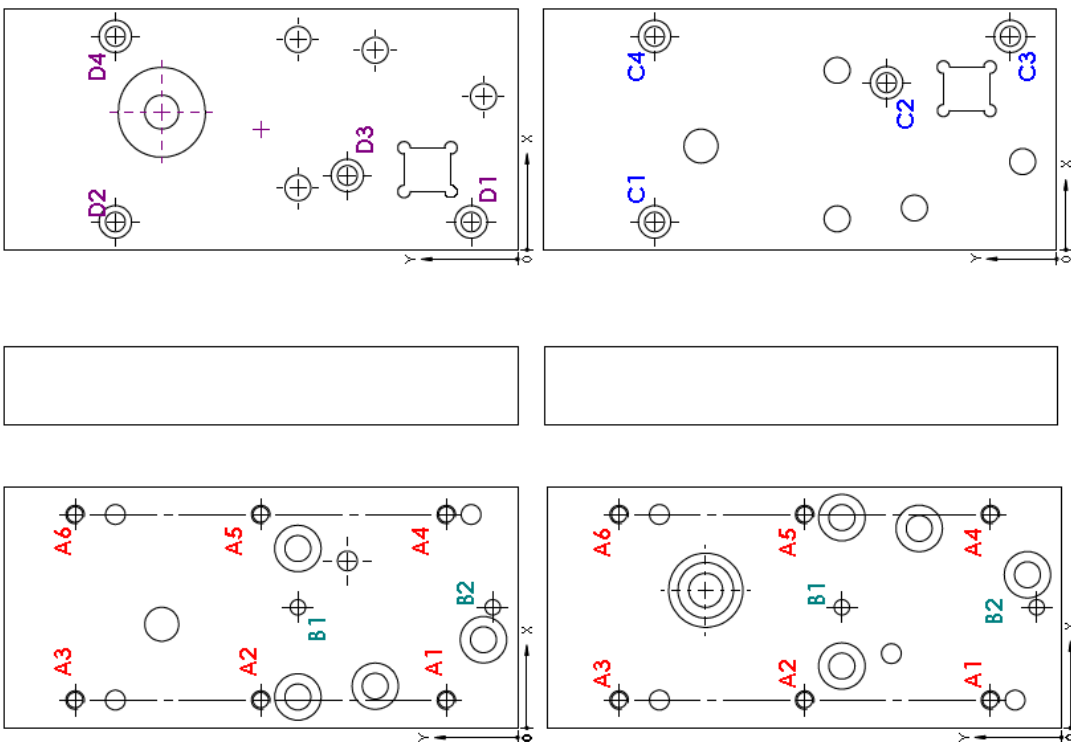

Gantry Rear		
Label	X-POS.	Y-POS.
D1	9	15
D2	9	130
D3	24	55
D4	69	130

Gantry Front		
Label	X-POS.	Y-POS.
C1	9	130
C2	54	55
C3	69	15
C4	69	130

F01-48 End Plate Dimensions		
Gezeichnet:	D. Marking:	Format:
05.06.2015	D. Marking	A2
Datensatzname:	Dimensiuebene:	
MTI AG, LinMot	Maxstab:	
	1:1	
Zeilungstimer		0180-0788-4
Änderungen		
Status:		05.06.2015 dm
Ersatz für:		
Material:		

Das Bild berechnet in diesem Dokument, das dem Empfänger persönlich anvertraut wird, bleibt unserer Firma. Ohne unsere schriftliche Genehmigung darf das Dokument weder kopiert noch veröffentlicht werden. Änderungen vorbehalten.

Declaration of Conformity CE-Marking

Manufacturer: NTI AG

LinMot®

Haerdlistrasse 15
8957 Spreitenbach
Switzerland

Tel.: +41 (0)56 419 9191 Fax: +41 (0)56 419 9192

Products: *LinMot*® Servo Motors

Type	Art.-No.	Type	Art.-No.
PS01-37Sx60-HP-N	0150-1295		
PS01-37Sx120F-HP-N	0150-1296		
PS01-37Sx120G-HP-N	0150-2379		
PS01-37Sx60-HP-N-AGI	0150-2549		
PS01-37Sx120F-HP-N-AGI	0150-2550		
PS01-48x240F-C	0150-1220		
PS01-48x360F-C	0150-1269		

The product must be mounted and used in strict accordance with the installation instruction contained within the User's Manual, a copy of which may be obtained from NTI AG.

I declare that as the authorized representative, the above information in relation to the supply/manufacture of this product is in conformity with the stated standards and other related documents in compliance with the protection requirements of the EMC Directive (89/336/EEC) and is marked in accordance with the CE Marking Directive (93/68/EEC).

Standards Complied with:

Conducted EMI	EN 55011	Class A
EN 61000-6-4		
Electromagnetic Susceptibility EMC	EN 61000-4-2	4 kV / 8kV
EN 61000-6-2	EN 61000-4-4	1 kV / 2kV
	EN 61000-4-3	10 V/m
	EN 61000-4-6	10 V
	ENV 50204	10 V/m

Company
NTI AG

Spreitenbach, May 2014

Dr.-Ing. Ronald Rohner / CEO NTI AG

Contact address:

NTI AG

LinMot
Haerdlistr. 15
CH-8957 Spreitenbach
Switzerland

Tel. +41 (0)56 419 9191
Fax. +41 (0)56 419 9192
email: office@LinMot.com
Web: www.LinMot.com

LinMot Inc.

204 E Morrissey Dr.
Elkhorn
WI 53121
USA

Phone: 262-743-2555
Fax: 262-723-6688
email: usasales@LinMot.com
Web: www.LinMot-usa.com

Liability

NTI AG / LinMot (LinMot) is not responsible for any damages caused by improper use, application, or handling of LinMot manufactured or supplied materials and is not responsible for any consequential damages of any sort relating to the use of LinMot products.

LinMot's warranty is limited to repair or replacement as stated in our standard warranty policy as described in our "terms and conditions" previously supplied to the purchaser of our equipment (please request copy of same if not otherwise available). Product warranties are void if LinMot products are used with stators, sliders, or controllers not manufactured by LinMot unless such use was specifically approved by LinMot.

A copy of this notice must be attached to each motor and/or machine that the purchaser provides to others.

LinMot®, LinRot® and MagSpring® are registered trademarks of NTI AG

Specification of products are subject to change without notification