

# MagSpring®

**MagSpring – Magnetic Springs**



**MagSpring, unlike mechanical springs, deliver a constant force over their entire working range**



**MagSpring, consist of only two components: a stator and a slider**



**MagSprings are totally passive. Their operation is based entirely on a unique application of permanent magnets – no electricity at all.**

**The constant force spring technology for industrial applications**

## Magnetic Spring MagSpring

MagSpring products can best be described as "magnetic springs." The term "spring", however, is to be understood to mean that MagSpring components generate a constant force over their entire working range, while the characteristic curve for a typical mechanical spring shows an increase in force with increasing displacement (see Fig. Right). The generation of force that is independent of the stroke makes MagSprings preferable for balancing weight forces in vertical drive applications. MagSpring products can best be described as "magneticSince MagSprings are purely passive elements, a defined function or position of a device can be ensured in a power-off condition. For example, a gripper or press head on a vertical mount can be held up, or a slider can be pushed in or pulled out with a constant force.

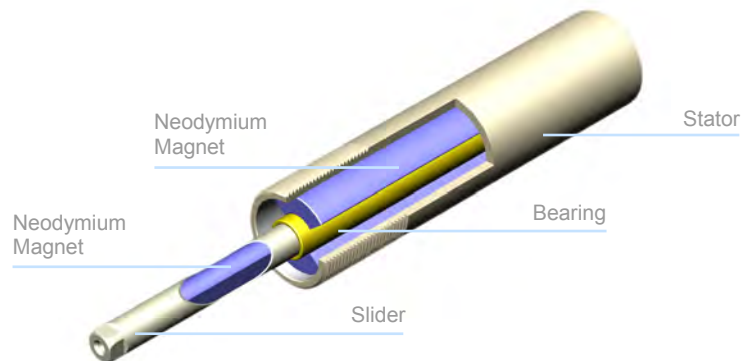

### Mode of Operation

The mode of operation is based on the attractive force of permanent magnets. Accordingly, no energy source (electricity, compressed air, etc.) is needed, so that safety-related applications can also be addressed. The special design of the flow-guiding components and the magnets translates the strongly non-linear relationship between force and displacement in magnet-iron arrangements into a constant force curve. Depending on the strength class of the MagSpring, the permanent magnets are either in the stator, in the slider, or in both components. The slider is guided by an integrated plain bearing, so that MagSprings can be used comparably to gas pressure springs in a design.



## MagSpring®

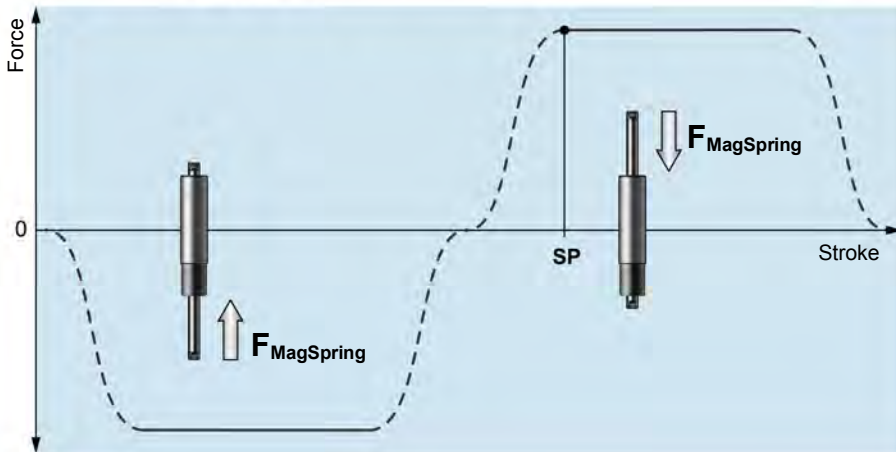

## Mechanical Spring

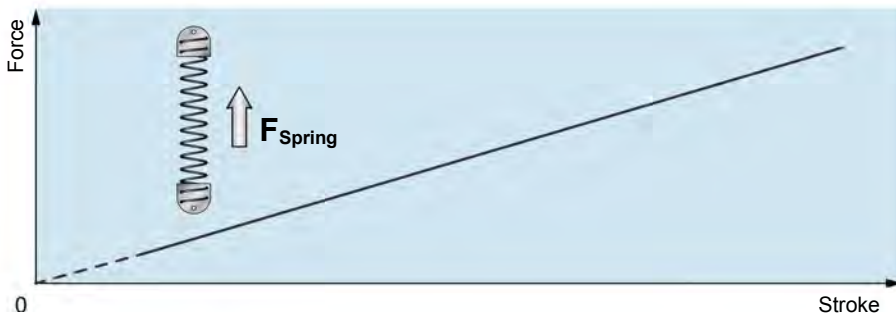

## Working Range

In the relaxed state, the slider is approximately centered in the stator, while the working end of the slider extends somewhat out of the end of the stator. (Fundamentally, however, both ends of the slider can be used to mount loads.) From this rest position, the slider can be pulled or pushed out of the stator in both directions. The force increases from zero to the nominal force within a short stroke length. The working stroke then continues with a constant force. The start position (SP) describes the distance between the working end of the slider and the end of the stator at the beginning of the constant force range.

## Application of Constant Force

Thanks to the constant force-displacement curve, many other applications are possible, such as the generation of a constant



press force, regardless of position; application of a constant holding force across a large stroke range; or single-sided force support in drive applications.

The effective force is in the range of +/- 10% of the nominal force, due to material and manufacturing tolerances.

## Holding Function (Power-off)

Since MagSprings are purely passive elements, a defined function or position of a device can be ensured in a power-off condition. For example, a gripper or press head on a vertical mount can be held up, or a slider can be pushed in or pulled out with a constant force.

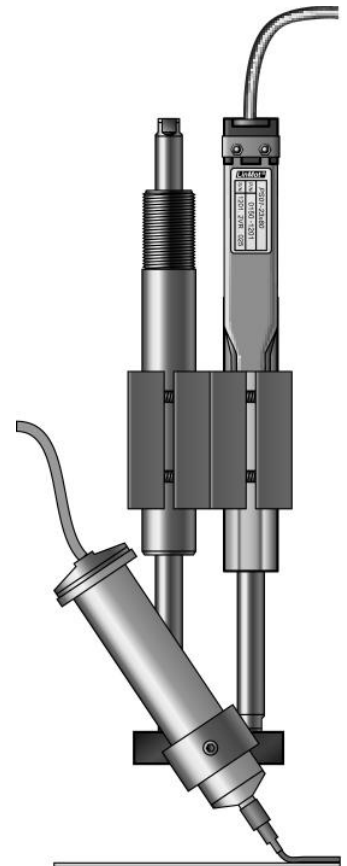

## M01-20x60/50: Force 11-22N / Stroke 50mm

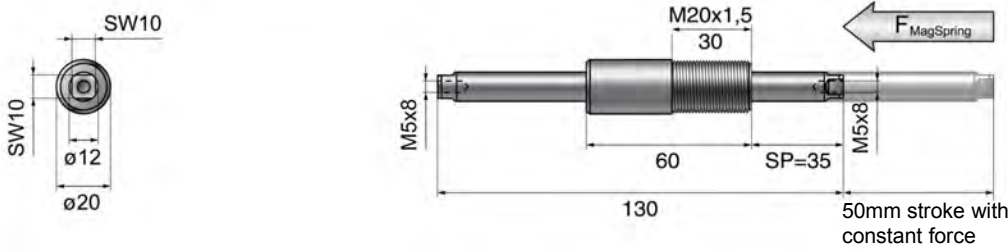

Dimensions in mm

The MagSpring has a constant force, as soon as the slider has been pulled out or pushed by the distance SP. The distance SP is measured between the unmarked slider end and the end of the stator (threaded end).

MagSpring	Constant force [N]	Stator mass [g (lb)]	Slider mass [g (lb)]
M01-20x60/50-11	11	75 (0.16)	75 (0.16)
M01-20x60/50-17	17	75 (0.16)	75 (0.16)
M01-20x60/50-22	22	75 (0.16)	75 (0.16)

## M01-20x140/130: Force 11-22N / Stroke 130mm

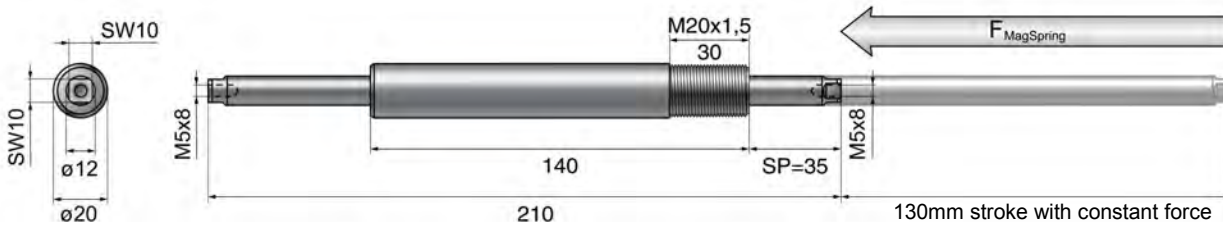

Dimensions in mm

The MagSpring has a constant force, as soon as the slider has been pulled out or pushed by the distance SP. The distance SP is measured between the unmarked slider end and the end of the stator (threaded end).

MagSpring	Constant force [N]	Stator mass [g (lb)]	Slider mass [g (lb)]
M01-20x140/130-11	11	180 (0.39)	155 (0.34)
M01-20x140/130-17	17	180 (0.39)	155 (0.34)
M01-20x140/130-22	22	180 (0.39)	155 (0.34)

## M01-20x220/210: Force 11-22N / Stroke 210mm

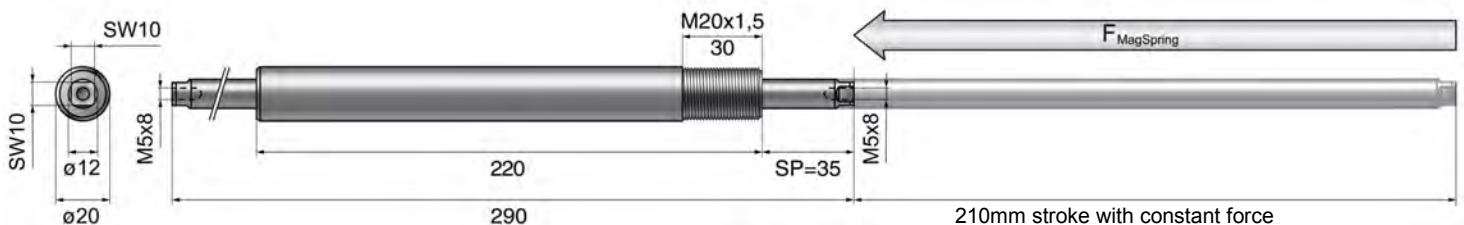

Dimensions in mm

The MagSpring has a constant force, as soon as the slider has been pulled out or pushed by the distance SP. The distance SP is measured between the unmarked slider end and the end of the stator (threaded end).

MagSpring	Constant force [N]	Stator mass [g (lb)]	Slider mass [g (lb)]
M01-20x220/210-11	11	285 (0.62)	220 (0.49)
M01-20x220/210-17	17	285 (0.62)	220 (0.49)
M01-20x220/210-22	22	285 (0.62)	220 (0.49)

## M01-20x300/290: Force 11-22N / Stroke 290mm

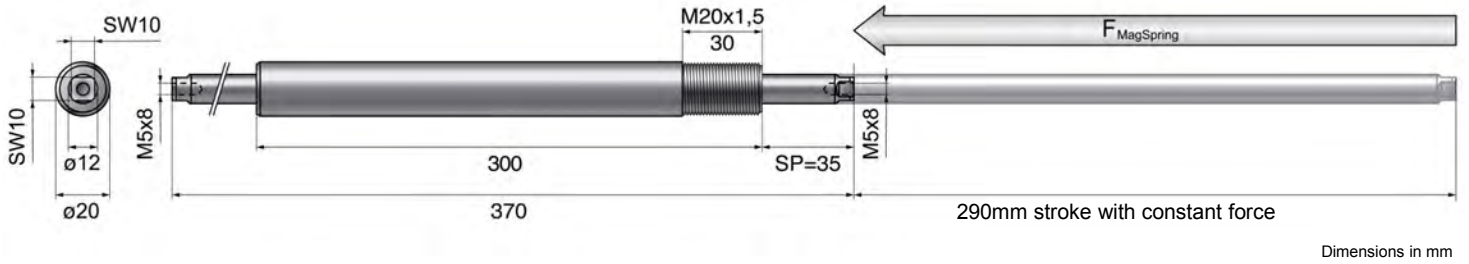

The MagSpring has a constant force, as soon as the slider has been pulled out or pushed by the distance SP.  
The distance SP is measured between the unmarked slider end and the end of the stator (threaded end).

MagSpring	Constant force [N]	Stator mass [g (lb)]	Slider mass [g (lb)]
M01-20x300/290-11	11	388 (0.86)	280 (0.61)
M01-20x300/290-17	17	388 (0.86)	280 (0.61)
M01-20x300/290-22	22	388 (0.86)	280 (0.61)



## Ordering Information

Stroke	Component	Part Number	Description	Code
M01-20x60/50	<b>MagSpring M01-20 with 50mm stroke</b>			
	Stator	MS01-20x60	MagSpring Stator 20x60mm	0250-2200
	Slider	ML01-12x130/80-10	Slider for MagSpring M01-20x60/50, Force 11N	0250-2300
		ML01-12x130/80-15	Slider for MagSpring M01-20x60/50, Force 17N	0250-2308
ML01-12x130/80-20		Slider for MagSpring M01-20x60/50, Force 22N	0250-2301	
M01-20x140/130	<b>MagSpring M01-20 with 130mm stroke</b>			
	Stator	MS01-20x140	MagSpring Stator 20x140mm	0250-2201
	Slider	ML01-12x210/160-10	Slider for MagSpring M01-20x140/130, Force 11N	0250-2302
		ML01-12x210/160-15	Slider for MagSpring M01-20x140/130, Force 17N	0250-2309
ML01-12x210/160-20		Slider for MagSpring M01-20x140/130, Force 22N	0250-2303	
M01-20x220/210	<b>MagSpring M01-20 with 210 mm stroke</b>			
	Stator	MS01-20x220	MagSpring Stator 20x220mm	0250-2202
	Slider	ML01-12x290/240-10	Slider for MagSpring M01-20x220/210, Force 11N	0250-2304
		ML01-12x290/240-15	Slider for MagSpring M01-20x220/210, Force 17N	0250-2310
ML01-12x290/240-20		Slider for MagSpring M01-20x220/210, Force 22N	0250-2305	
M01-20x300/290	<b>MagSpring M01-20 with 290mm stroke</b>			
	Stator	MS01-20x300	MagSpring Stator 20x140mm	0250-2207
	Slider	ML01-12x370/320-10	Slider for MagSpring M01-20x300/290, Force 11N	0250-2311
		ML01-12x370/320-15	Slider for MagSpring M01-20x300/290, Force 17N	0250-2312
ML01-12x370/320-20		Slider for MagSpring M01-20x300/290, Force 22N	0250-2313	

## M01-37x80/50: Force 40-60N / Stroke 50mm

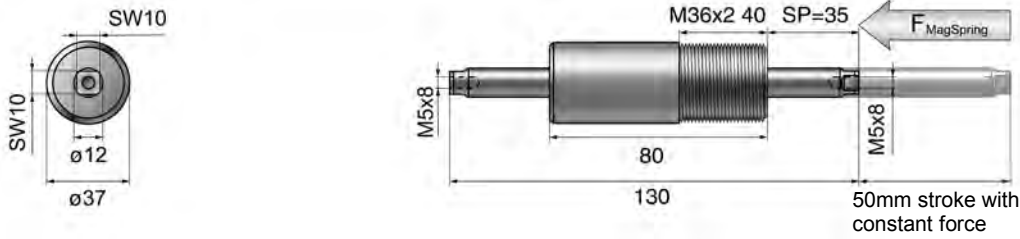

Dimensions in mm

The MagSpring has a constant force, as soon as the slider has been pulled out or pushed by the distance SP. The distance SP is measured between the unmarked slider end and the end of the stator (threaded end).

MagSpring	Constant force [N]	Stator mass [g (lb)]	Slider mass [g (lb)]
M01-37x80/50-40	40	440 (0.90)	75 (0.16)
M01-37x80/50-50	50	440 (0.90)	75 (0.16)
M01-37x80/50-60	60	440 (0.90)	75 (0.16)

## M01-20x140/130: Force 11-22N / Stroke 130mm

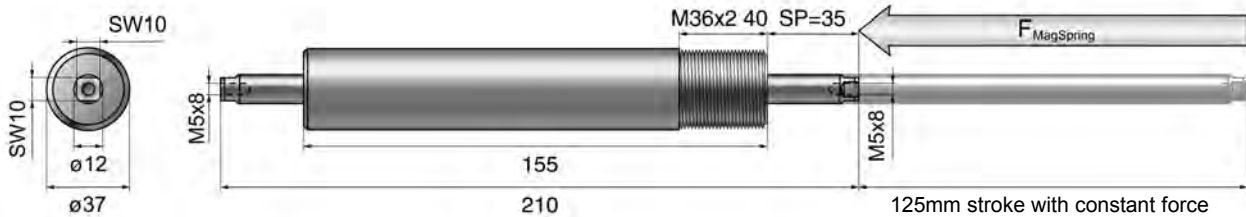

Dimensions in mm

The MagSpring has a constant force, as soon as the slider has been pulled out or pushed by the distance SP. The distance SP is measured between the unmarked slider end and the end of the stator (threaded end).

MagSpring	Constant force [N]	Stator mass [g (lb)]	Slider mass [g (lb)]
M01-37x155/125-40	40	880 (1.80)	155 (0.34)
M01-37x155/125-50	50	880 (1.80)	155 (0.34)
M01-37x155/125-60	60	880 (1.80)	155 (0.34)

## M01-37x230/200: Force 40-60N / Stroke 200mm

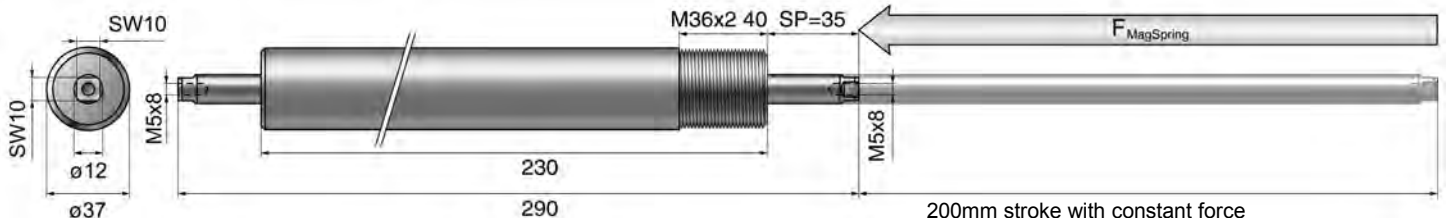

Dimensions in mm

The MagSpring has a constant force, as soon as the slider has been pulled out or pushed by the distance SP. The distance SP is measured between the unmarked slider end and the end of the stator (threaded end).

MagSpring	Constant force [N]	Stator mass [g (lb)]	Slider mass [g (lb)]
M01-37x230/200-40	40	1320 (2.70)	220 (0.49)
M01-37x230/200-50	50	1320 (2.70)	220 (0.49)
M01-37x230/200-60	60	1320 (2.70)	220 (0.49)

## M01-37x305/275: Force 40-60N / Stroke 275mm

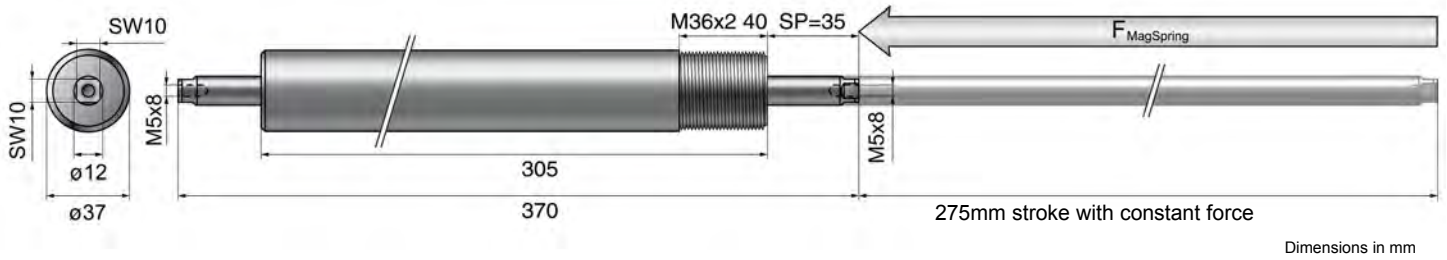

The MagSpring has a constant force, as soon as the slider has been pulled out or pushed by the distance SP. The distance SP is measured between the unmarked slider end and the end of the stator (threaded end).

MagSpring	Constant force [N]	Stator mass [g (lb)]	Slider mass [g (lb)]
M01-37x305/275-40	40	1800 (3.90)	280 (0.61)
M01-37x305/275-50	50	1800 (3.90)	280 (0.61)
M01-37x305/275-60	60	1800 (3.90)	280 (0.61)



## Ordering Information

<b>M01-37x80/50</b>	<b>MagSpring M01-37 with 50mm stroke</b>			
	Stator	MS01-37x80	MagSpring Stator 37x80mm	0250-2203
	Slider	ML01-12x130/80-10	Slider for MagSpring M01-37x80/50, Force 40N	0250-2300
		ML01-12x130/80-15	Slider for MagSpring M01-37x80/50, Force 50N	0250-2308
ML01-12x130/80-20		Slider for MagSpring M01-37x80/50, Force 60N	0250-2301	
<b>M01-37x155/125</b>	<b>MagSpring M01-37 with 125mm stroke</b>			
	Stator	MS01-37x155	MagSpring Stator 37x155mm	0250-2204
	Slider	ML01-12x210/160-10	Slider for MagSpring M01-37x155/125, Force 40N	0250-2302
		ML01-12x210/160-15	Slider for MagSpring M01-37x155/125, Force 50N	0250-2309
ML01-12x210/160-20		Slider for MagSpring M01-37x155/125, Force 60N	0250-2303	
<b>M01-37x230/200</b>	<b>MagSprings M01-37 with 200mm stroke</b>			
	Stator	MS01-37x230	MagSpring Stator 37x230mm	0250-2205
	Slider	ML01-12x290/240-10	Slider for MagSpring M01-37x230/200, Force 40N	0250-2304
		ML01-12x290/240-15	Slider for MagSpring M01-37x230/200, Force 50N	0250-2310
ML01-12x290/240-20		Slider for MagSpring M01-37x230/200, Force 60N	0250-2305	
<b>M01-37x305/275</b>	<b>MagSprings M01-37 with 275mm stroke</b>			
	Stator	MS01-37x305	MagSpring Stator 37x305mm	0250-2206
	Slider	ML01-12x370/320-10	Slider for MagSpring M01-37x305/275, Force 40N	0250-2311
		ML01-12x370/320-15	Slider for MagSpring M01-37x305/275, Force 50N	0250-2312
ML01-12x370/320-20		Slider for MagSpring M01-37x305/275, Force 60N	0250-2313	

## Flange and Adaptor for MagSpring



## Flange for MagSpring M01-20

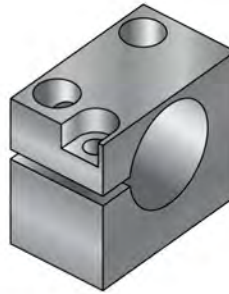
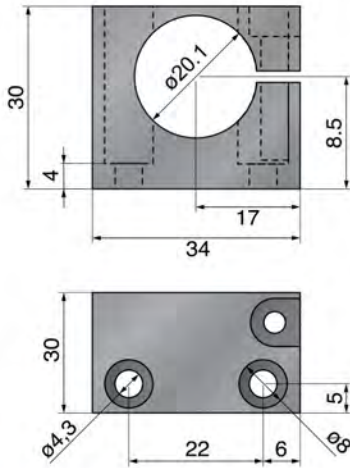

Material: Aluminum (AlMgSi), black anodized  
 Mass: approx. 30g (0.066lb)

Dimensions in mm

Item	Description	Part Number
MF01-20/H23	Flange MagSpring M01-20 - fits guides H01-23	0250-2306

## Flange for MagSpring M01-37

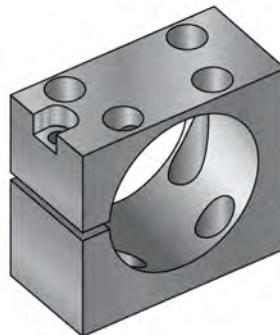
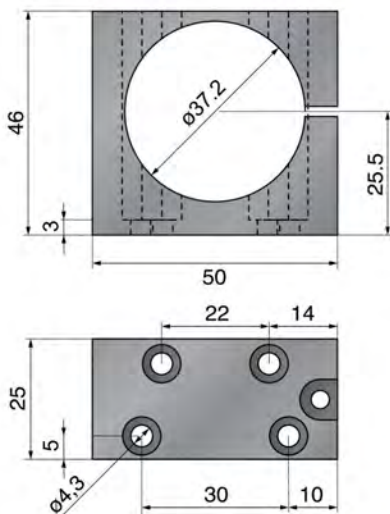

Material: Aluminum (AlMgSi), black anodized  
 Mass: approx. 70g (0.15lb)

Dimensions in mm

Item	Description	Part Number
MF01-37/H37	Flange MagSpring M01-20 - fits guides H01-37 and B01-37 - fits guides H01-48 and B01-48	0250-2307



## Adaptor for MagSpring M01-20 and Guides H01-23

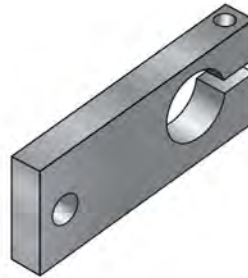
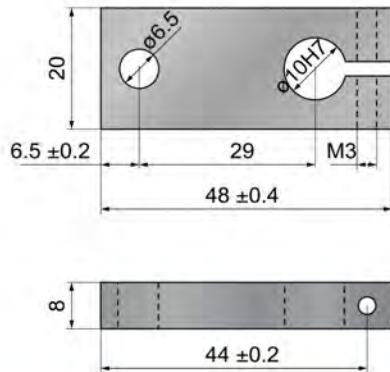

Material: Aluminum (AlMgSi), black anodized  
Mass: approx. 18g (0.066lb)

Dimensions in mm

Item	Description	Part Number
MA01-20/H23	Adaptor MagSpring M01-20 / Guides H01-23	0250-0116

## Adaptor for MagSpring M01-37 and Guides H01-37 / B01-37

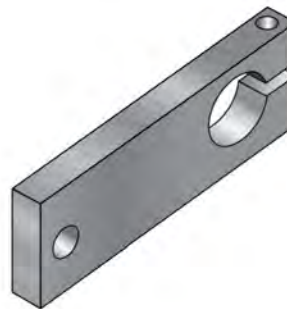
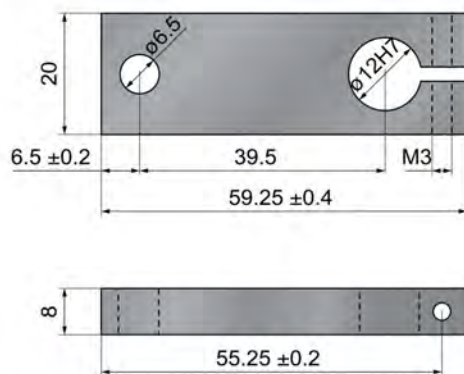

Material: Aluminum (AlMgSi), black anodized  
Mass: approx. 18g (0.066lb)

Dimensions in mm

Item	Description	Part Number
MA01-37/H37	Adaptor MagSpring M01-37 / Guides H01-37 and B01-37	0250-0117

## Adaptor for MagSpring M01-37 and Guides H01-48 / B01-48

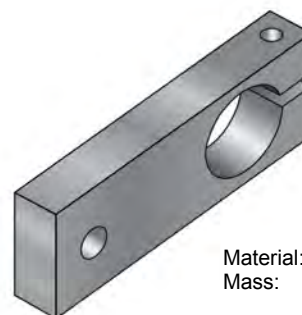
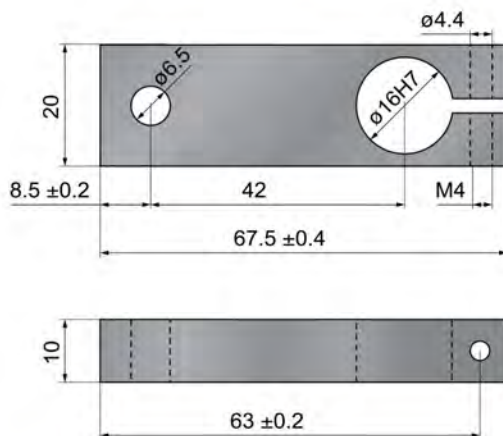

Material: Aluminum (AlMgSi), black anodized  
Mass: approx. 32g (0.034lb)

Dimensions in mm

Item	Description	Part Number
MA01-37/H48	Adaptor MagSpring M01-37 / Guides H01-48 and B01-48	0250-0118

Mounting flanges and adapters are available for mounting MagSpring magnetic springs. Using these accessories, the magnetic springs can be mounted directly on an H01 linear guide or a B01 bridge guide.

The flange for mounting the MagSpring stators is secured with T-nuts in the T-slot provided for this purpose on the linear or bridge guide.

For weight balancing in vertical installations, the lower slider end of the MagSpring is attached to the guide shaft of the guide using the adapter.

Depending on the installation orientation of the guide, the adapter is attached to the guide shaft at the front mounting plate (motor on top) or the rear end of the guide shaft (motor on the bottom).

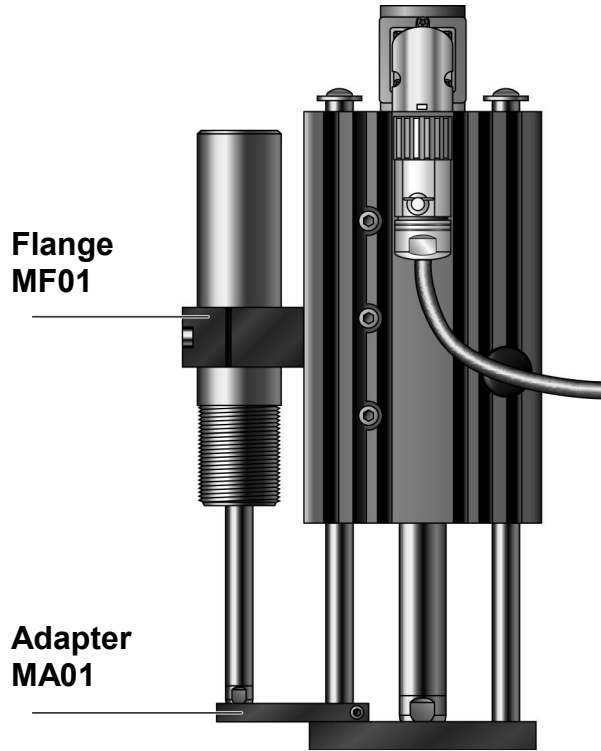

**Motor on the top**



**Motor on the bottom**



## Combination with H-Guides

The illustration to the right shows a vertical arrangement of an H01 linear guide together with a MagSpring. The MagSpring presses upward with a constant force. The weight load is balanced by the MagSpring, and the linear motor thus bears less load.

If the electrical power supply is interrupted, the MagSpring supports the load, or moves it into a safe waiting position.



## Materials



Slider:  
Chromium-Nickel Steel 1.4301



Stator:  
Iron, electroless nickel plated



Bearing:  
POM based

## Mounting

The stators can be mounted via the screw thread, or with a clamp, as desired. There are appropriate mounting flanges for both sizes. When attaching the slider to the load mass, care should be taken that any parallelism errors are compensated for with a flexible coupler.

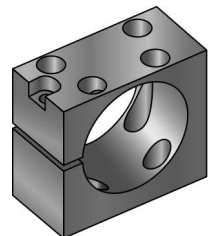

# MagSpring<sup>®</sup>

## Magnetic Springs

*Remove Gravity from  
your Application*

#### **NTI AG**

Haerdlistrasse 15  
CH - 8957 Spreitenbach  
Tel.: +41-(0)56-419 91 91  
Fax: +41-(0)56-419 91 92  
E-Mail: [office@linmot.com](mailto:office@linmot.com)  
Web: [www.linmot.com](http://www.linmot.com)

#### **LinMot USA, Inc.**

204 E Morrissey Dr  
Elkhorn, WI 53121  
Tel.: 262-743-2555  
Fax: 800-463-8708  
E-Mail: [usasales@linmot.com](mailto:usasales@linmot.com)  
Web: [www.linmotusa.com](http://www.linmotusa.com)

Copyright Spaceimage by NASA